



T2

Recon Nailing System R1.5

Operative Technique

Hip & Femur Fractures



T2 Recon Nailing System

Contributing Surgeons

We greatly acknowledge and appreciate the contributions to this operative technique made by:

Kevin W. Luke, M.D.

Parkview Orthopaedic Group
Assistant Clinical Professor
Department of Orthopaedic Surgery
University of Illinois
Illinois, Chicago
USA

Anthony T. Sorkin, M.D.

Rockford Orthopaedic Associates, LLP
Clinical Instructor
Dep. of Surgery University of Illinois
College of Medicine
Director Orthopaedic Traumatology
Rockford Memorial Hospital
Rockford, Illinois
USA

Ariaan D.P. van Walsum, MD

Trauma surgeon
Medical Spectrum Twente
Enschede
Netherlands

Don Weber, MD, FRCSC

Associate Clinical Professor of
Orthopaedics
Chief of Orthopaedics
University of Alberta Hospital
Edmonton, Alberta
Canada

This publication sets forth detailed recommended procedures for using Stryker Osteosynthesis devices and instruments.

It offers guidance that you should heed, but, as with any such technical guide, each surgeon must consider the particular needs of each patient and make appropriate adjustments when and as required.

A workshop training is required prior to first surgery.

All non-sterile devices must be cleaned and sterilized before use. Follow the instructions provided in our reprocessing guide (L24002000). Multi-component instruments must be disassembled for cleaning. Please refer to the corresponding assembly/disassembly instructions.

See package insert (L22000007) for a complete list of potential adverse effects, contraindications, warnings and precautions. The surgeon must discuss all relevant risks, including the finite lifetime of the device, with the patient, when necessary.

Warning:

**Fixation Screws:
Stryker Osteosynthesis bone screws are not approved or intended for screw attachment or fixation to the posterior elements (pedicles) of the cervical, thoracic or lumbar spine.**

Contents

	Page
1. Introduction & Features	5
Implant Features	5
Technical Specifications	6
Instrument Features	7
2. Indications, Precautions & Contraindications	8
3. Pre-operative Planning	9
4. Locking Options	10
5. Operative Technique	11
Patient Positioning and Fracture Reduction	11
Incision	11
Entry Point	12
Reaming	14
Nail Selection	16
Assembly of the Targeting Device and the Nail	17
Nail Insertion	18
Final Seating with Impactor	18
Guided Locking for the Recon Mode	19
Guided Locking for Antegrade Femoral Mode	29
Freehand Distal Locking	32
Set Screw or End Cap Insertion	34
Nail Removal	34
<hr/>	
Ordering Information – Implants	35
Ordering Information – Instruments	37

Introduction

Introduction

Over the past decades antegrade and retrograde femoral nailing have become widely accepted choices for the treatment of femoral fractures.

The T2 Recon nail is one of the first femoral nailing systems to offer a greater trochanter entry point with both recon and antegrade locking options.

Through the development of a common, streamlined instrument system and intuitive surgical approach, both in principle and in detail, the T2 Recon Nail offers the potential for more efficient treatment of fractures as well as simplifying the training requirements for all personnel involved.

Furthermore, the T2 Recon Nail offers the following competitive advantages:

- **Versatility - offers the ability to switch from antegrade to a recon option without changing either the nail or targeting arm.**
- **Recon Set Screw - this optional screw sets the most proximal Lag Screw thus minimizing the potential for screw sliding (Z-effect).**
- **Locking Options - distal options include dynamic as well as static.**
- **Distal Targeting - eliminates the need for freehand locking of either the static or dynamic modes. Requires optional Gamma3/T2 Recon DTS R1.5**

Implant Features

The T2 Recon Nail is the realization of excellent biomechanical intramedullary stabilization for internal femoral fixation with several locking options to address fracture variability.

As with all other T2 Nails, the T2 Recon Nail is made of **Type II anodized Titanium Alloy (Ti6Al4V) for enhanced biomechanical and biomedical performance***.

The T2 Recon Nail features a **125° CCD angle with a 10° anteversion angle. The 2 proximal holes, each utilize 6.5mm cannulated Lag Screws.** This CCD angle allows easy insertion of the 2 lag screws into the femoral head.

Alternatively a **proximal 70° Oblique hole with 7° retroversion** provides a 5mm Fully Threaded Screw for targeting the lesser trochanter in the Femoral Antegrade mode.

The 6.5 mm Cannulated Lag Screws have a unique thread design that provide an excellent grip. Improved front cutting flutes allow for lesser insertion torque and thinner flanks for less bone removal.

Secure placement of the Lag Screws within small neck diameters can be achieved due to 10mm separating the two 6.5mm lag screws or 17mm outer distance between the 6.5mm Lag screws.

Two Set Screws are available:

- **Recon Set Screw:** Tightens the 6.5mm proximal Lag Screw (Recon Mode) and
- **Antegrade Set Screw:** Tightens the oblique 5mm Fully Threaded Screw (Femoral Antegrade Mode).

Available as **left and right versions**, the T2 Recon Nail incorporates an antecurvature radius of **1.5M**, as well as a **4° medial lateral bend** for trochanteric insertion.

The **distal locking configuration** features a round and an oblong hole to allow for **static and / or dynamic distal locking.**

Low profile 5mm cortical screws, common to the T2 Nailing System, are designed to simplify the surgical procedure and promote a minimally invasive approach.

5mm Fully Threaded Locking Screws are available for distal locking (Recon or Femoral Antegrade Mode) and for the proximal locking in Femoral Antegrade Mode.

End Caps are available in various lengths to provide a better fit.

See the detailed chart on the next page for the design specifications and size offerings.

* Axel Baumann, Nils Zander, Ti6Al4V with Anodization Type II: Biological Behaviour and Biomechanical Effects, White Paper, March 2005.

Introduction

Technical Specifications

Nail Diameter 9, 10, 11, 12, 13 and 15mm
(Left and Right)

Sizes 260–480mm,
in 20mm increments

Note:

- Proximal diameter is 13mm for the 9, 10, 11 and 12mm Nails and 15mm for the 13 and 15mm Nails.
- Check with your local representative regarding availability of nail sizes.

5.0mm Fully Threaded Locking Screws

L = 25–120mm

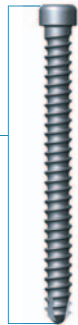

6.5mm Cannulated Lag Screws

L = 65–130mm

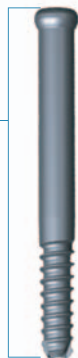

Note:

Screw length is measured from top of head to tip.

End Caps



Recon Set Screw

Antegrade Set Screw

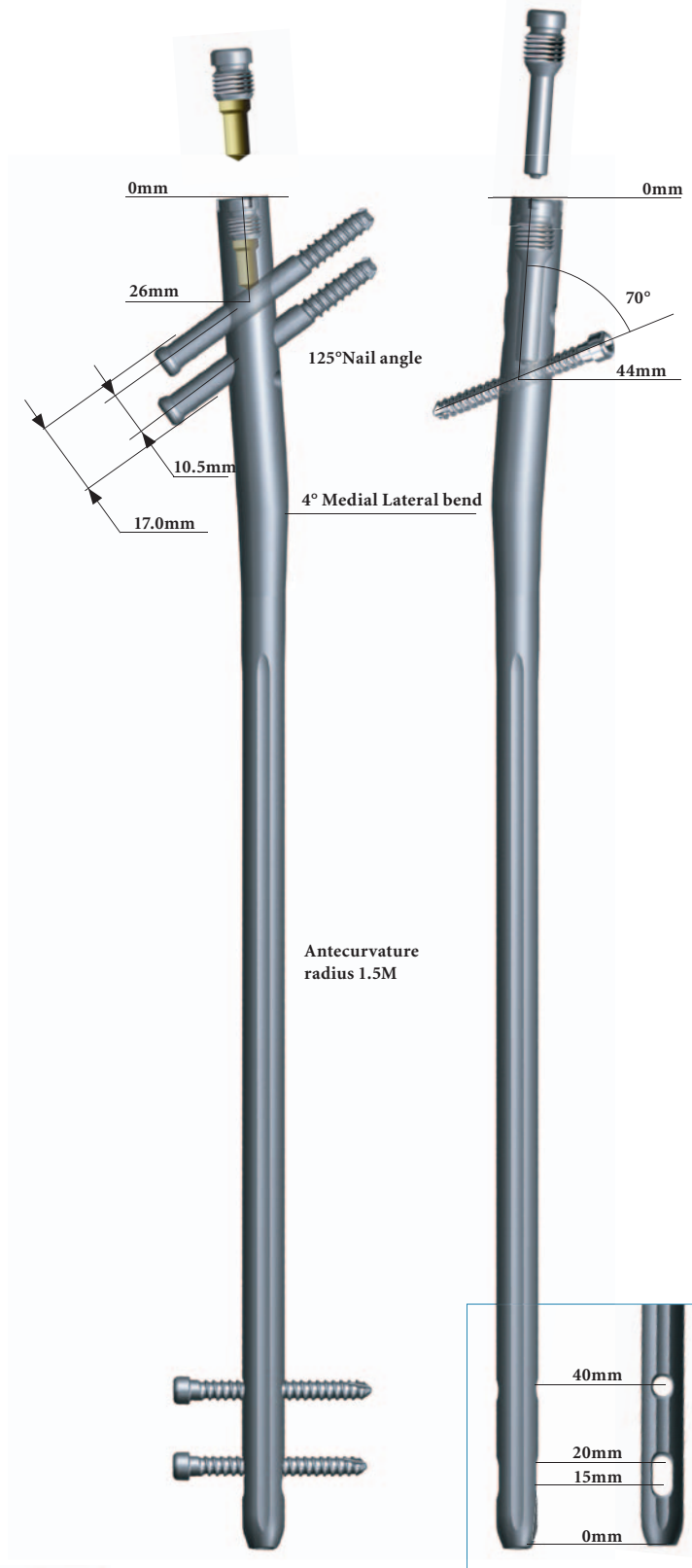

Introduction

Instrument Features

A major advantage of the T2 instrument platform is the integration of core instruments that can be used not only for the complete T2 Nailing System, but for future Stryker Osteosynthesis nailing systems, thereby, reducing complexity and inventory.

The T2 instrument platform offers precision and usability, as well as ergonomically styled targeting devices.

Except for the addition of a small number of dedicated instruments, the T2 Femur instrument platform is used for the T2 Recon Nail.

The T2 Recon targeting device is designed to provide two proximal locking options: Recon or Antegrade Femoral Modes.

Recon mode: Provides two (2) proximal holes targeting the femoral neck and head:

- **B** Targets the Proximal Recon 6.5 mm Lag Screw
- **A** Targets the Distal Recon 6.5 mm Lag Screw

Antegrade Femoral Mode: Provides a single 5mm Oblique Screw targeting the lesser trochanter. **LEFT** is used for a left nail and **RIGHT** for a right nail.

With the exception of the carbon fiber targeting device, dedicated instruments for the recon mode are color coded with “bronze”. This makes it easy to differentiate them from the core T2 instrument platform.

Drills

Drills feature color coded rings:

4.2mm = Green

(Consistent with the Gamma3 and T2 Instrument Platform, this drill features a green color ring.)

The 4.2mm drills are used for 5.0mm Fully Threaded Locking Screws (either for distal locking or for proximal oblique locking).

6.5mm

The Solid Stepdrill for the Lag Screw is color coded with “bronze”.



Indications, Precautions & Contraindications

Indications

The T2 Recon Nail is indicated for:

- Subtrochanteric fractures
- Intertrochanteric fractures
- Ipsilateral neck/shaft fractures
- Comminuted proximal femoral shaft fractures
- Femoral fixation required as a result of pathological disease
- Temporary stabilization of fractures of the femoral shaft - ranging from the femoral neck to the supracondylar regions of the femur.

Contraindications

The physician's education, training and professional judgement must be relied upon to choose the most appropriate device and treatment. Conditions presenting an increased risk of failure include:

- Any active or suspected latent infection or marked local inflammation in or about the affected area.
- Compromised vascularity that would inhibit adequate blood supply to the fracture or the operative site.
- Bone stock compromised by disease, infection or prior implantation that can not provide adequate support and/or fixation of the devices.
- Material sensitivity, documented or suspected.
- Obesity. An overweight or obese patient can produce loads on the implant that can lead to failure of the fixation of the device or to failure of the device itself.
- Patients having inadequate tissue coverage over the operative site.
- Implant utilization that would interfere with anatomical structures or physiological performance.
- Any mental or neuromuscular disorder which would create an unacceptable risk of fixation failure or complications in postoperative care.
- Other medical or surgical conditions which would preclude the potential benefit of surgery.

Precautions

Stryker Osteosynthesis systems have not been evaluated for safety and use in MR environment and have not been tested for heating or migration in the MR environment, unless specified otherwise in the product labeling or respective operative technique.

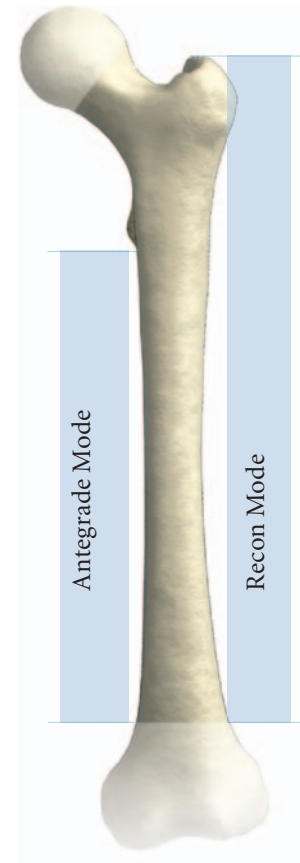

Pre-Operative Planning

An X-Ray Recon Template (1806-3082) is available for pre-operative planning. Thorough evaluation of pre-operative radiographs of the affected extremity is critical. Careful radiographic examination of the trochanteric region and neck regions can reduce the potential of intra-operative complications.

Note:

The X-Ray Recon Template features a scale of 1.1:1 which is adapted to conventional analogous X-Rays. For digital X-Rays, attention has to be paid that the magnification is corresponding with the template.

According to the fracture type either Recon or Antegrade Femoral Mode can be chosen.

Evaluation of the femoral neck angle on the pre-operative X-Rays is mandatory as the T2 Recon Nail has a fixed 125° neck angle for the two Lag Screws. Proper placement of both Lag Screws in the femoral head is essential.

If possible, X-Rays of the contralateral side should be used to determine the normal neck angle and length of the femur.

The proper nail length should extend from the tip of the greater trochanter to the epiphyseal scar.

Note:

Check with your local representative regarding availability of nail sizes.

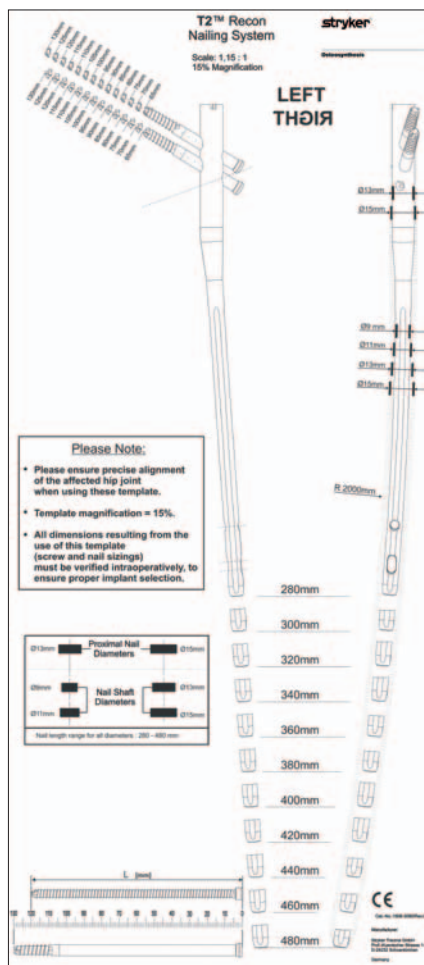

Locking Options

Recon Mode

The T2 Recon Nail can be locked proximally with two 6.5mm Lag Screws (Recon Mode, Fig. 1) or with one 5mm Fully Threaded Screw (Antegrade Femoral Mode, Fig. 2).

For both Recon and Antegrade Femoral applications, depending on fracture pattern, either static or dynamic distal locking can be used.

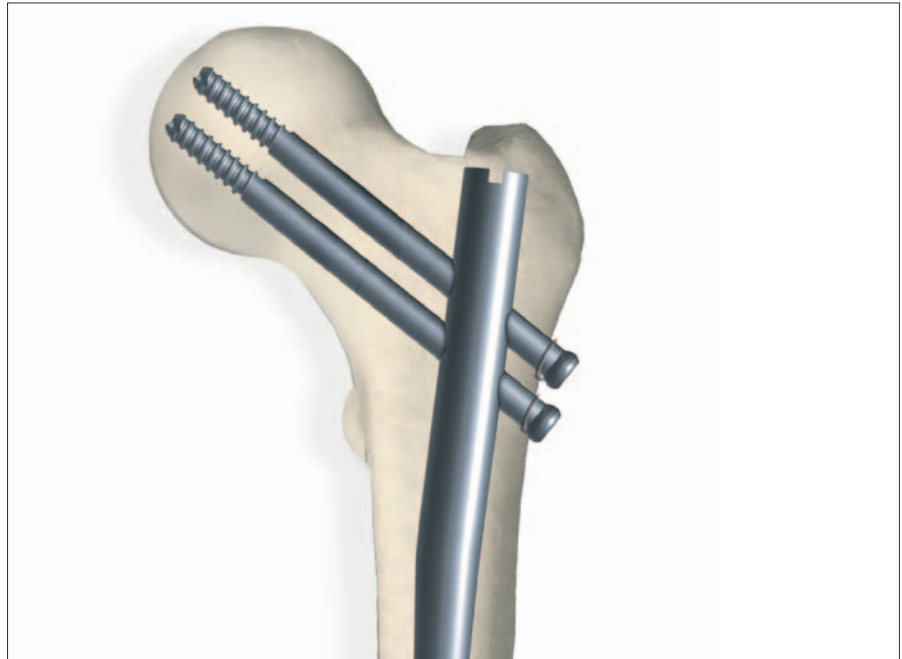

Fig. 1

Antegrade Femoral Mode

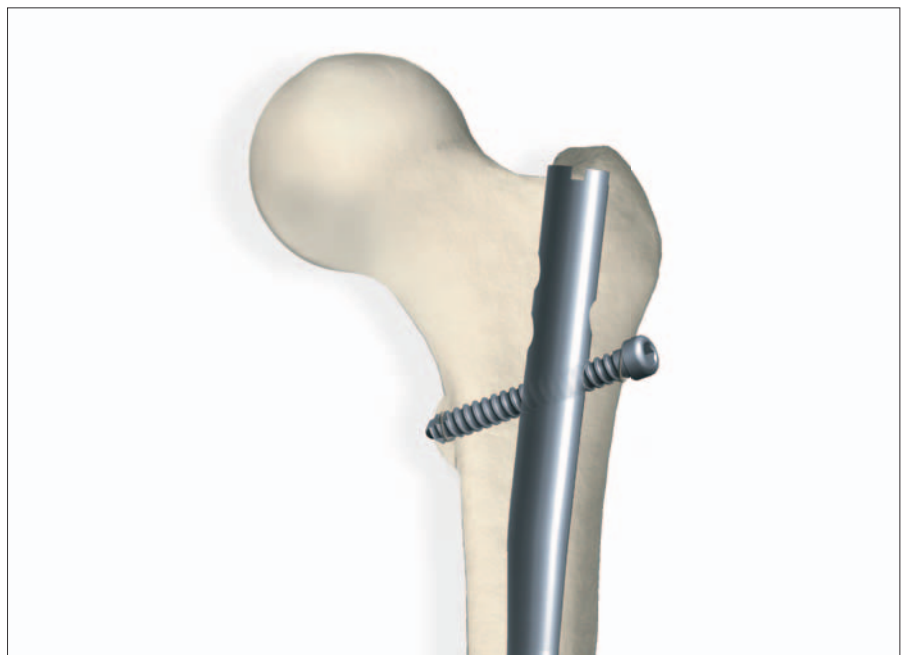

Fig. 2

Operative Technique

Patient Positioning and Fracture Reduction

Patient positioning for T2 Recon Nail insertion is surgeon dependent. However, it is recommended that patients are positioned in either the supine or lateral position on a fracture table to allow closed reduction of the fracture (Fig. 3).

Manipulate and reduce the fracture in the usual fashion, according to the fracture type. Reduction should be achieved as anatomically as possible. If this is not possible, reduction in one plane should be complete, leaving reduction in the other plane to be achieved prior to reaming and nail insertion.

The unaffected leg is abducted as far as possible to ease image intensifier positioning. This will also allow easier access to entry point.

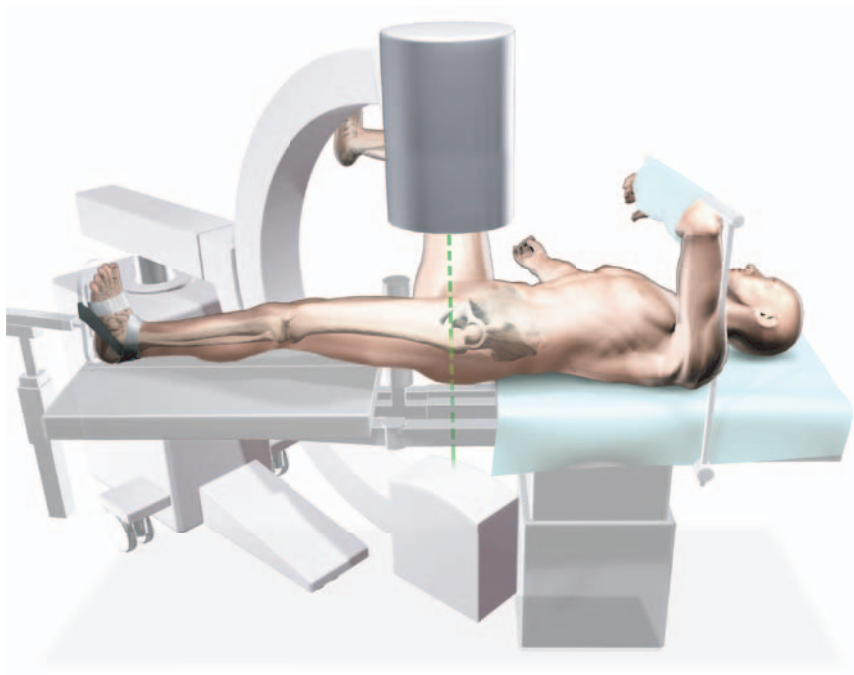

Fig. 3

Incision

The design of the T2 Recon Nail, with a **4° medial lateral bend**, will **only** allow for insertion through the **tip of the greater trochanter**.

With experience, the tip of the greater trochanter can be identified by palpation (Fig. 4).

A longitudinal skin incision of approximately 3–5cm is made starting just above the greater trochanter to the iliac crest (Fig. 5). The incision is then deepened to expose the tip of greater trochanter.

Smaller or larger incisions may be used based on individual patients anatomy and at the surgeon's discretion.

Note:

The targeting instruments of the T2 Recon Nail have been designed to allow for a more percutaneous approach.

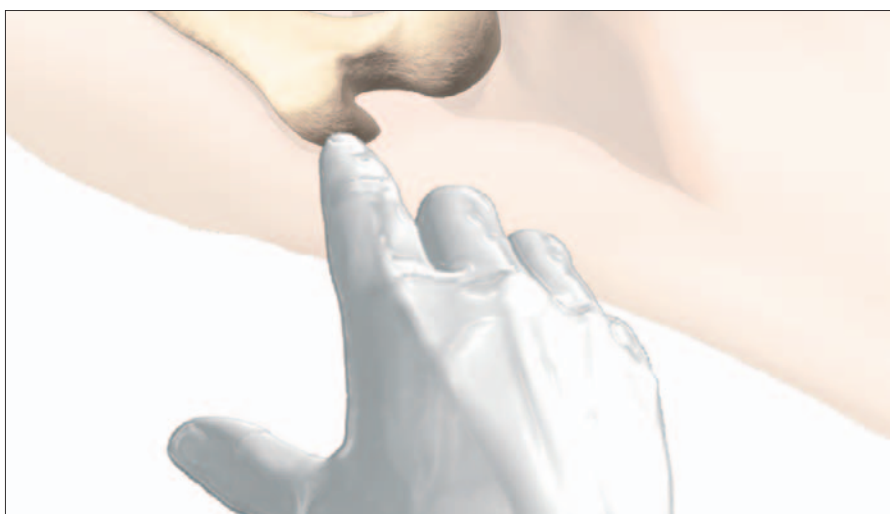

Fig. 4

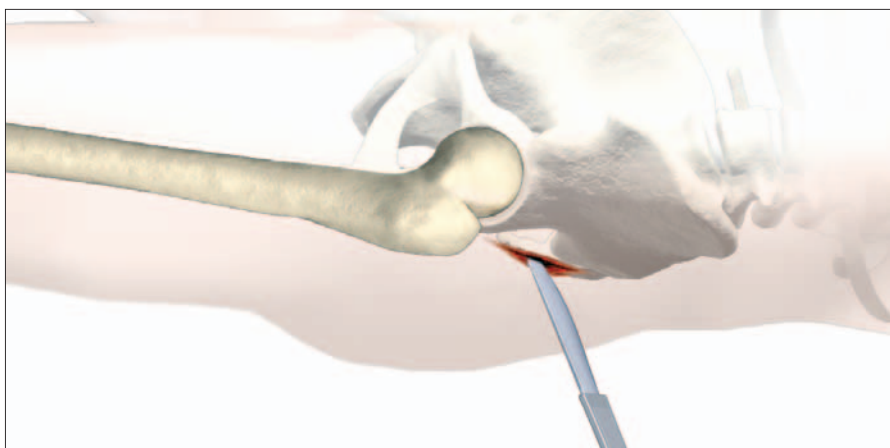

Fig. 5

Operative Technique

Entry Point

• The Tip of the Greater Trochanter

The entry point is located at the junction of the anterior third and posterior two-thirds of the greater trochanter on the medial edge of the tip itself (Fig. 6).

Note:

Before opening the tip of greater trochanter, image intensifier views (A/P and M/L) should be used to confirm correct identification of the entry point.

The medullary canal can be opened with the

- Curved Awl/Curved Awl, 90° Handle or
- One Step Conical Reamer.

Note:

Dense cortical bone may block the tip of the Awl during opening of the entry portal. Inserting first the optional Awl Plug into the Awl will avoid penetration of bone debris into the cannulated Awl shaft. The Awl Plug is then removed for Guide Wire insertion.

• Entry point with Curved Awl

Once the tip of the greater trochanter has been opened (Fig. 7a), the Ø3 × 1000mm Ball Tip Guide Wire may be advanced through the cannulation of the Curved Awl with the Guide Wire Handle and Chuck (Fig. 7b).

The proximal femur may then be prepared with the One Step Conical Reamer.

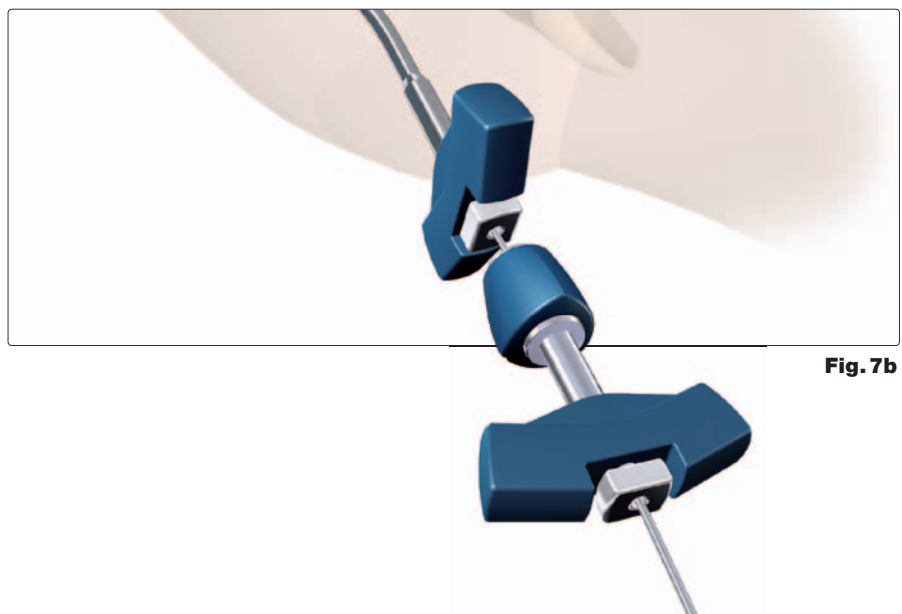
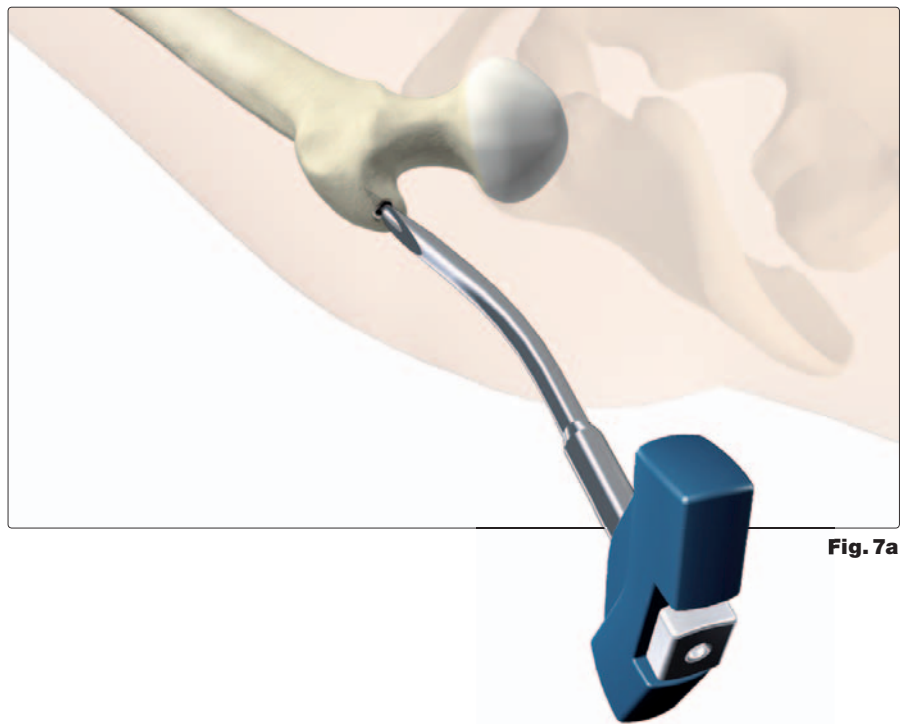
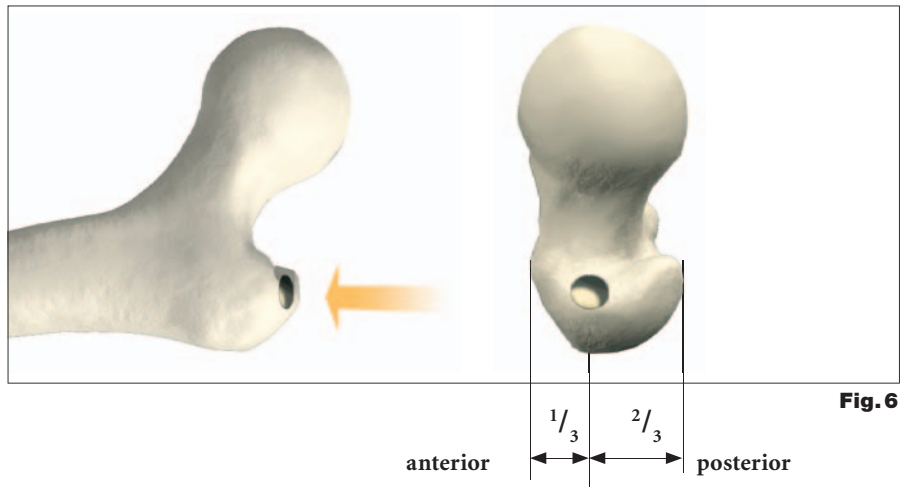

Operative Technique

• Entry point with One Step Conical Reamer

Alternatively, the 13mm diameter One Step Conical Reamer for the 9 and 11mm nails or the 15mm diameter Reamer for the 13 and 15mm nails may be used for opening the medullary canal and reaming of the trochanteric region.

Under image intensification control, the entry point is made with a $\text{Ø}3.2 \times 400\text{mm}$ Recon K-Wire which is attached to the Guide Wire Handle and advanced into the medullary canal. Confirm its placement within the center of the medullary canal on A/P and lateral image intensifier views.

Note:

The Recon K-Wire used for the entry point should not be used again for the Lag Screw insertion. It is recommended that a new K-Wire be utilized.

The Recon Protection Sleeve and Multi-hole Trocar are positioned with the central hole over the K-Wire.

Note:

The Multi-hole Trocar has a special design for more precise insertion of the $\text{Ø}3.2\text{mm}$ Recon K-Wire (Fig. 8). Beside the central hole, 4 other holes are located eccentrically at different distances from the center (Fig. 8a) to easily revise insertion of the guiding K-Wire in the proper position (entry point).

When correct placement of the guiding Recon K-Wire is confirmed on image intensifier views (A/P and lateral), keep the Tissue Protection Sleeve in place and remove the Multi-hole Trocar.

The T-Handle is attached to the One Step Conical Reamer and hand reaming is performed over the Recon K-Wire through the Tissue Protection Sleeve (Fig. 9).

The Recon K-Wire is then removed and replaced with the $\text{Ø}3 \times 1000\text{mm}$ Ball Tip Guide Wire.

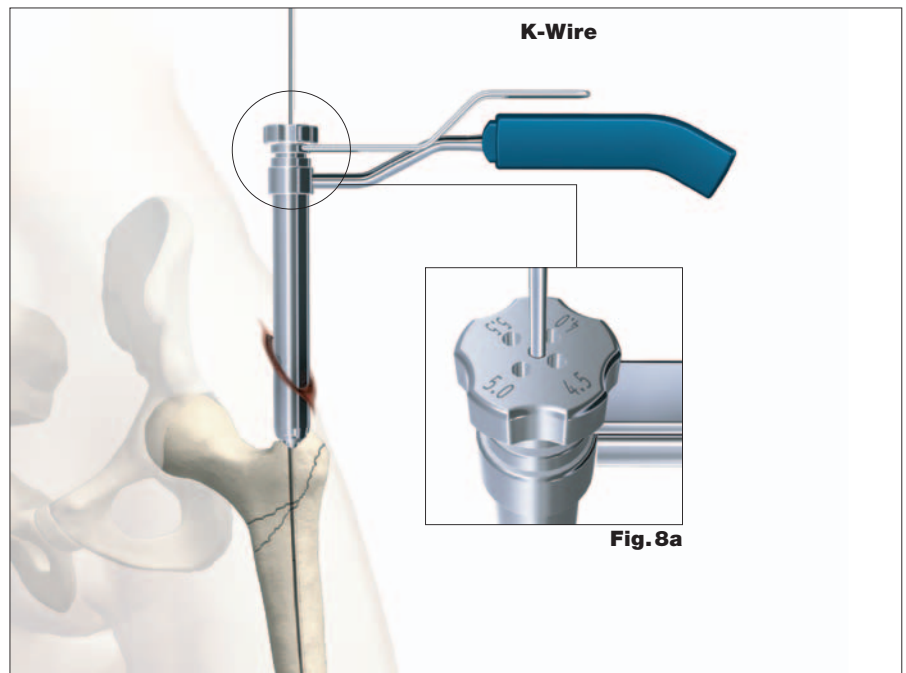

Fig. 8

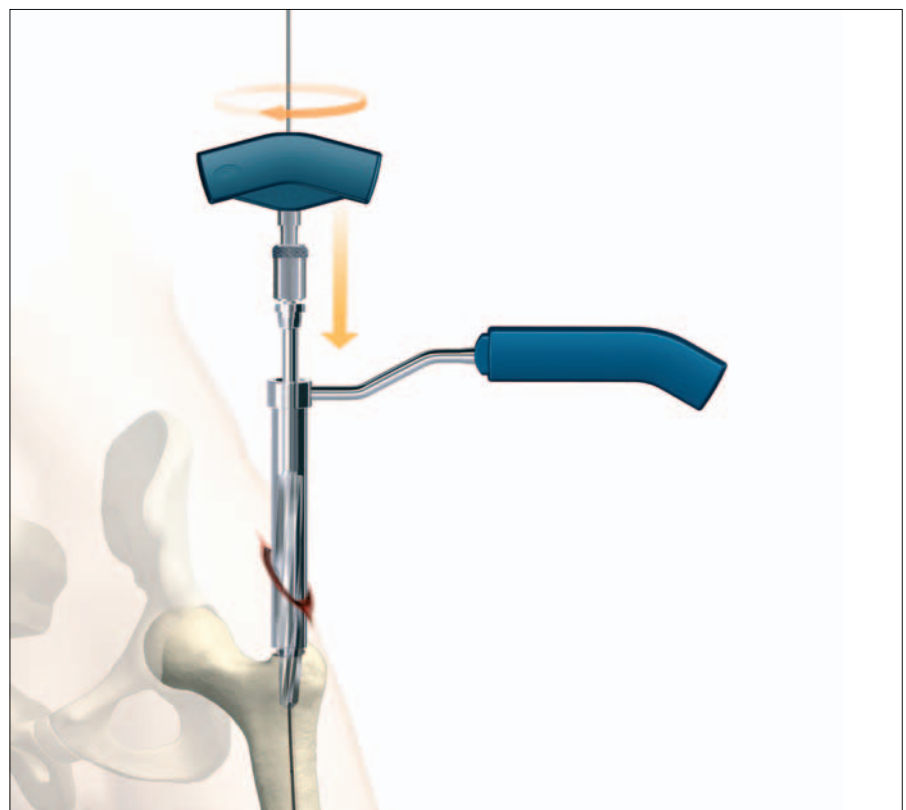

Fig. 9

Operative Technique

Reaming

The $\text{\O} 3 \times 1000\text{mm}$ Ball Tip Guide Wire is inserted with the Guide Wire Handle through the fracture site to the level of the epiphyseal scar.

The $\text{\O} 9\text{mm}$ Universal Rod with Reduction Spoon may be used as a fracture reduction tool to facilitate Guide Wire insertion through the fracture site (Fig. 10).

Note:

The Ball Tip at the end of the Guide Wire will stop the Bixcut reamer* head (Fig. 11).

Caution:

Prior to reaming, it is important to check the centered intramedullary position of the Guide Wire with the image intensifier. Lateral displacement of the Guide Wire could lead to resection of more bone on the lateral side of the wire, which in turn will lead to an offset position of the nail and increase the risk of a shaft fracture.

Note:

Make sure that the reduction is maintained throughout the reaming process.

Reaming is commenced in 0.5mm increments until cortical contact occurs (Fig. 12).

For easier nail insertion, the medullary canal should be reamed at least 2mm more than the diameter of selected nail (Fig. 13).

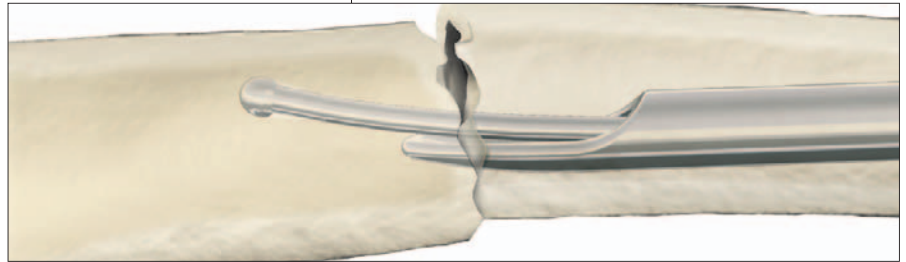
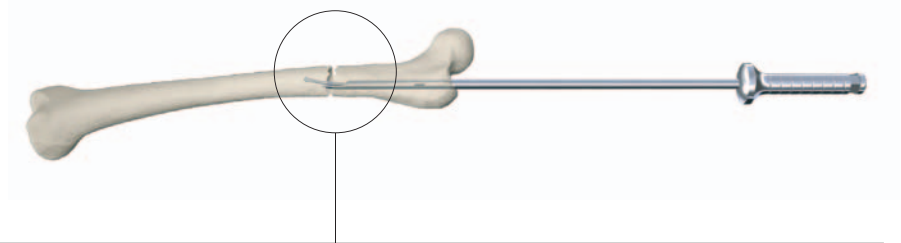

Fig. 10



Fig. 11

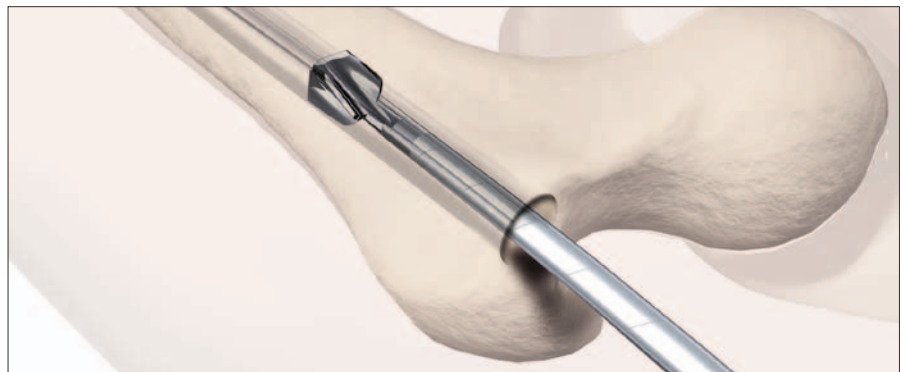

Fig. 12

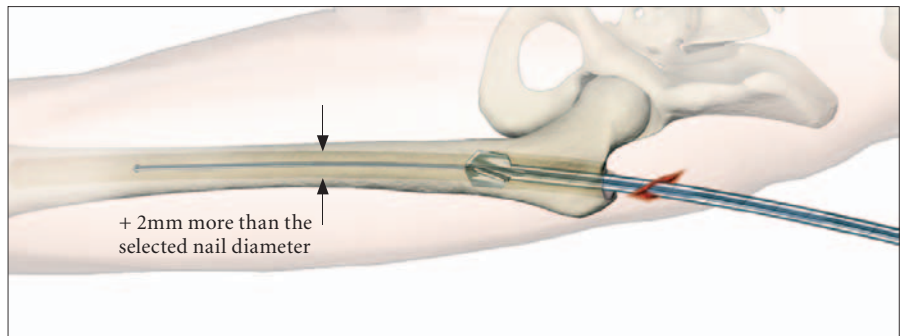

Fig. 13

* see pages 36-37 for additional Bixcut Reamer system details

Operative Technique

The Guide Wire Pusher can be used to keep the Guide Wire in position during reamer shaft extraction. The metal cavity at the end of the blue Elastosil handle may be placed on the end of Guide Wire. Applying pressure to hold the Guide Wire in place while removing the drill under power. (Fig. 14).

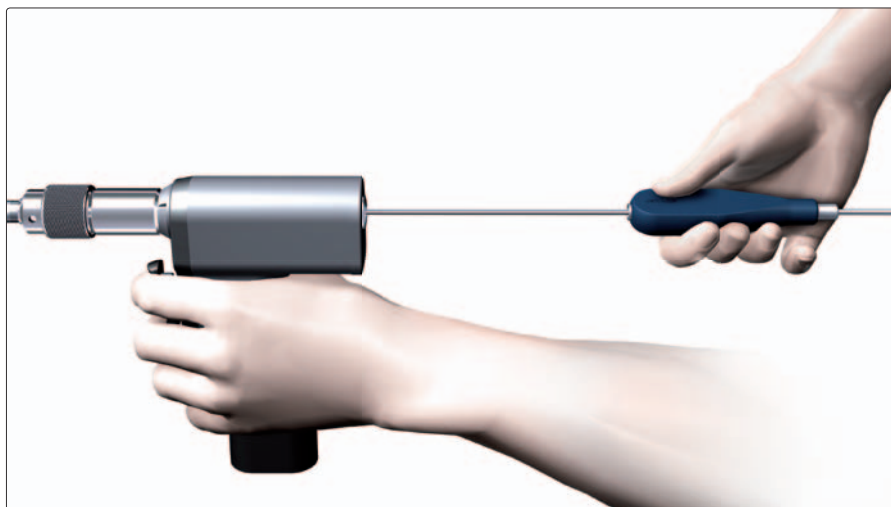

Fig. 14

When close to the Guide Wire end, place the Guide Wire Pusher with its funnel tip at the end of the power tool cannulation (Fig. 15).

While removing the power tool the Guide Wire Pusher will keep the Guide Wire in place.

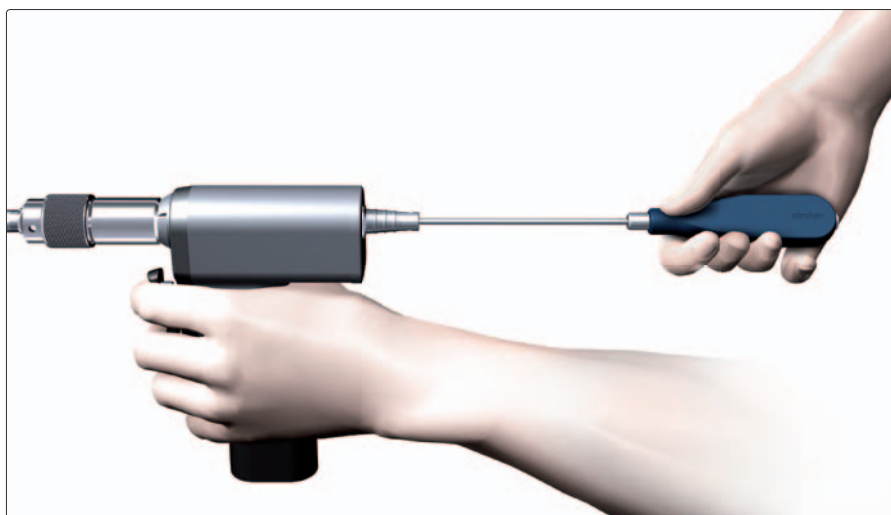

Fig. 15



Guide Wire Pusher (1806-0271)

Note:

The T2 Recon Nail may be inserted without reaming of the subtrochanteric and diaphyseal region of the femur, particularly in elderly patients with wide medullary canals. If appropriate, after the trochanteric region has been prepared with the One Step Conical Reamer, the nail can be inserted without further reaming of the medullary canal.

Reaming of the trochanteric region is needed (Fig. 13) as the proximal nail diameter (driving end) is larger than the nail diameter (13mm for the 9, 10, 11 and 12mm diameter nails and 15mm for the 13 and 15mm diameter nails). For both reamed or unreamed applications, the proximal 5cm of the trochanteric region must be opened to at least 13mm or 15mm, depending on the proximal diameter of the nail.

Operative Technique

Nail Selection

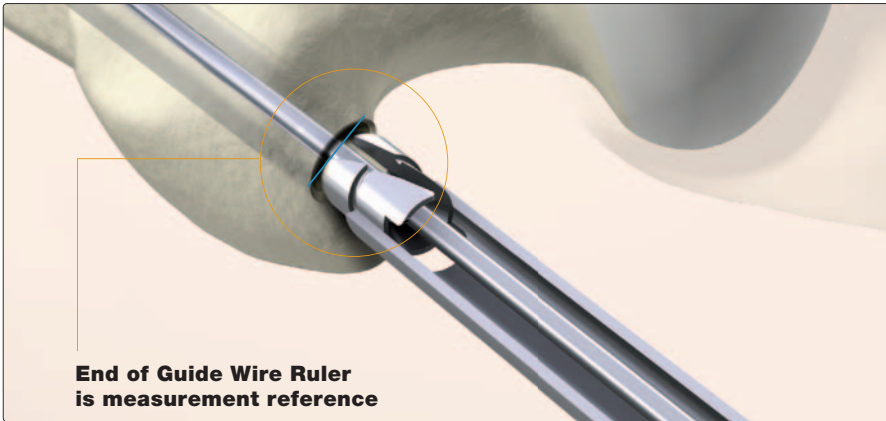

Fig. 16a

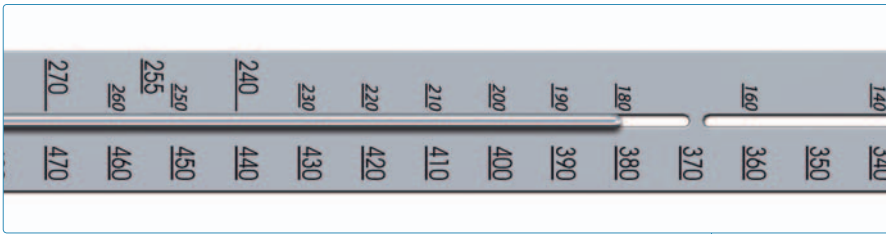

Fig. 16b



Fig. 17a

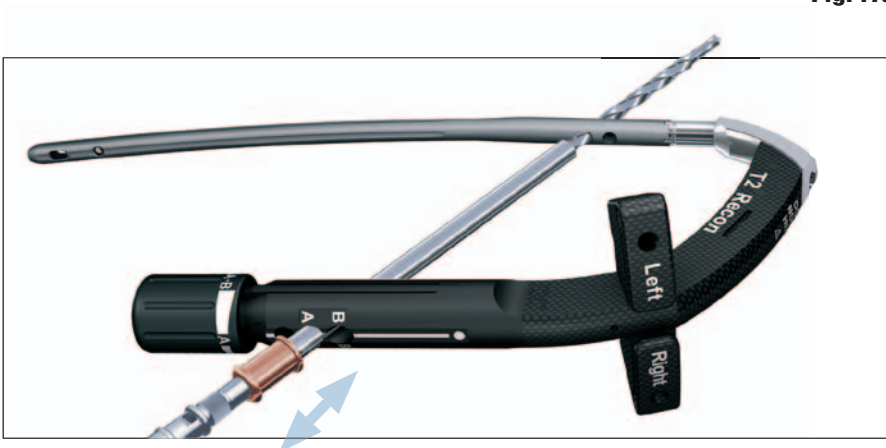

Fig. 17b

Diameter

The diameter of the selected nail should be at least 2.0mm smaller than that of the last reamer used.

Length

Nail length may be determined by measuring the remaining length of the Guide Wire. The Guide Wire Ruler may be used by placing it on the Guide Wire and reading the correct nail length at the end of the Guide Wire on the Guide Wire Ruler (Fig. 16a, b).

Upon completion of reaming, the appropriate size nail is ready for insertion. A unique design feature of the T2 Recon Nail is that the $\text{Ø}3 \times 1000\text{mm}$ Ball Tip Guide Wire does not need to be exchanged.

The selected nail is assembled onto the Targeting Arm with the Nail Holding Screw (Fig. 17a). Be sure to securely tighten the Nail Holding Screw with the Screwdriver Shaft, Ball Tip and T-Handle so that it does not loosen during nail insertion.

Caution:

Prior to the nail insertion, check the correct assembly by passing the Stepdrill for Lag Screw through the Recon Tissue Protection Sleeve and Drill Sleeve, Recon (placed in the corresponding hole of the Targeting Arm) and through the holes of the nail (Fig. 17b).

For the Antegrade Femoral Mode, use the targeting hole for Antegrade with the Tissue Protection Sleeve and Drill Sleeve assembly to pass the $\text{Ø}4.2 \times 340\text{mm}$ Drill through the oblique hole of the nail.

Operative Technique

Assembly of Targeting Device

First, assemble the Knob to the Targeting Device by aligning the arrow on the Knob with the white line on the Target Sleeve, (Fig. 18a) then push hard to click it.

By turning the Knob clockwise to the position labeled (A), the sleeve inserted in target (A) position, which is the distal Recon Mode targeting hole, can be locked. (Fig. 18b)

By further turning the Knob clockwise to the position labeled (A+B), both sleeves inserted in (A) and (B), which are the both proximal and distal recon mode targeting holes, can be locked. (Fig. 18c)

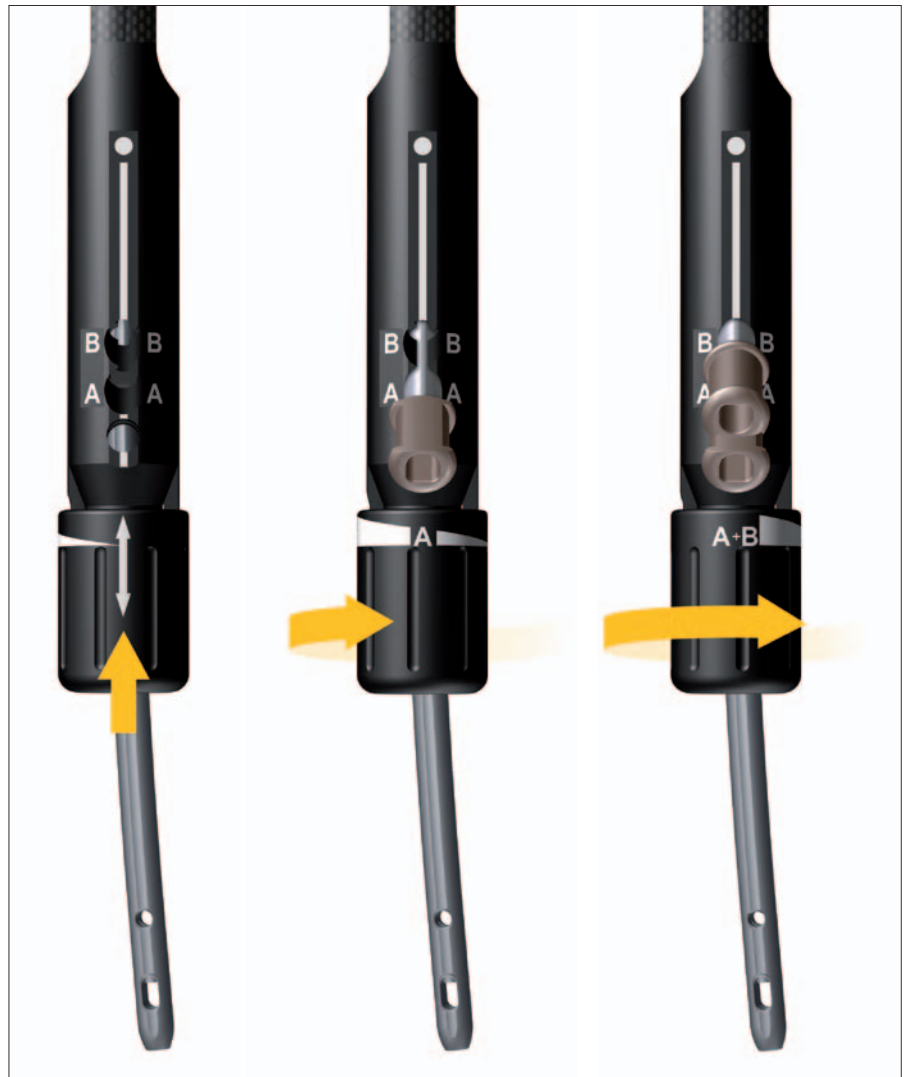

Fig. 18a

Fig. 18b

Fig. 18c

Operative Technique

Nail Insertion

The nail is advanced through the entry point passing the fracture site to the appropriate level.

If dense bone is encountered, first re-evaluate that sufficient reaming has been achieved, then, if necessary, the Strike Plate can be attached to the Targeting Arm and the Slotted Hammer may be used to further insert the nail (Fig. 19).

Caution:

The nail must progress smoothly, without excessive force. If too much resistance is encountered, removal of the nail and additional reaming is recommended.

Note:

Remove the Guide Wire prior to drilling or K-Wire insertion.

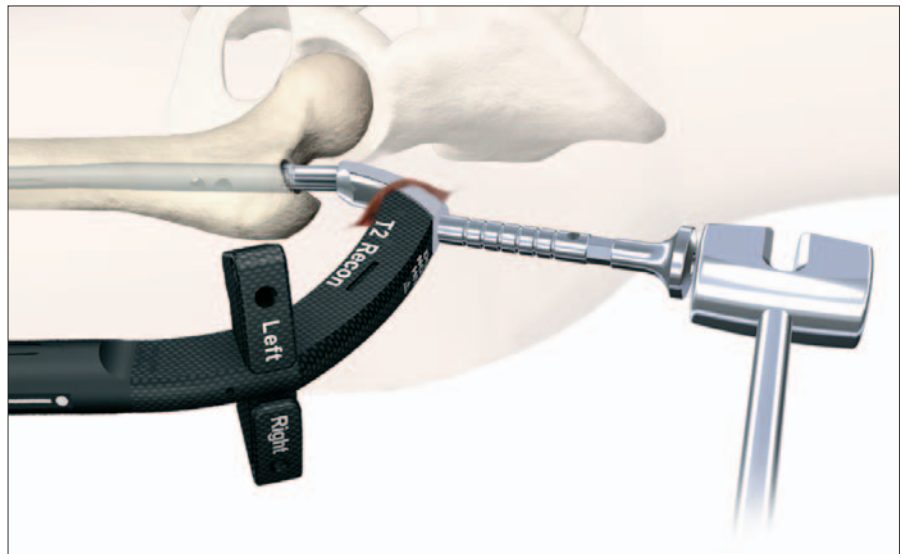

Fig. 19

Final Seating with Impactor

The carbon fiber guide should never be struck as it may break or become deformed. The impactor that is provided can be utilized to assist with final seating of the nail. Gentle tapping will produce small adjustments (in the nail position) that can help to optimize the ultimate position of the lag screw in the femoral head. The nail holding screw should be re-tightened following any use of the impactor.

The impactor should not be utilized to force the nail down the canal. If the nail cannot be seated manually or if there is no advancement each time the impactor is tapped, A/P and Lateral fluoroscopic X-Rays should be reviewed to determine the cause of the impingement - there may be a mismatch between the nail geometry and the medullary canal. The starting position, the femoral bow and the canal diameter should all be examined to ensure that the leading end of the nail is not impinging on the medial or anterior cortex and that the canal itself has been sufficiently reamed.

Periodically, nail removal and further reaming of the diaphysis may be required.

The proximal metaphyseal flair may be undersized (particularly in young patients or those of short stature) and serve to prevent nail advancement. If this situation is encountered, a flexible reamer may be used to further widen this area to the level of the lesser trochanter.

To facilitate manual passage, the nail internally rotated 90° until the fracture has been passed.

Operative Technique

Guided Locking for the Recon Mode

Nail/Lag Screws Positioning

Drive the T2 Recon Nail to the depth that correctly aligns the proximal screw holes parallel with the femoral head and neck under fluoroscopic control (Fig. 20).

Two aspects regarding the Nail/Lag Screws position must be carefully checked with the image intensifier before drilling into the femoral head:

- Alignment of the anteversion (M//L view)
- Depth of nail insertion (A/P view).

The distal Lag Screw should run along the calcar region (on the A/P view) and centered into the femoral neck and head (on the M/L view).

Note:

The use of the One Shot Device (1213-3010) is recommended to predetermine the optimal Lag Screw placement. Details are described on Page 20 to 21.

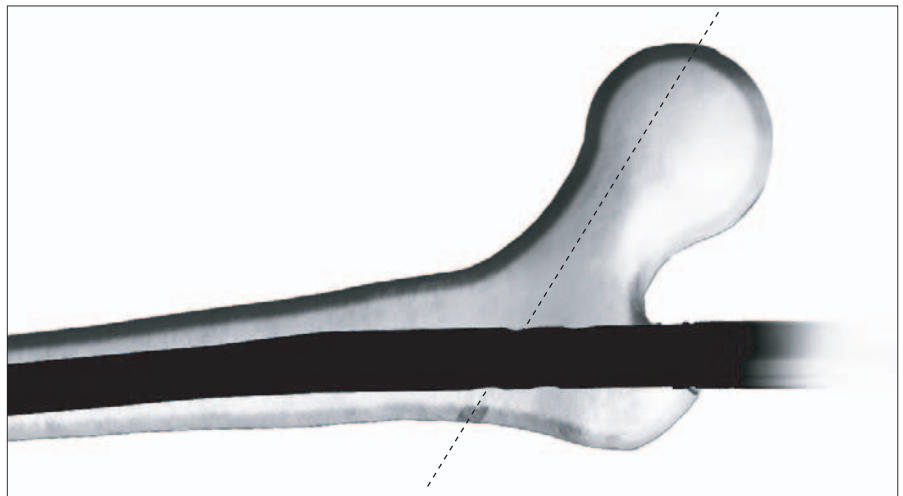

Fig. 20



Fig. 20a

Operative Technique

Now attach the Recon Paddle Trocar to the T-Handle, AO Medium Coupling (Fig. 21).

Then, advance them together with the Recon Tissue Protection Sleeve to the skin through the hole on the Target Device labeled (A). Make a small skin incision and push the assembly through until it is in contact with the lateral cortex. Then turn the Knob clockwise to the position labeled (A) (Fig. 22).

Remove the Trocar and then insert the Recon K-Wire Sleeve through the Tissue Protection Sleeve. Place a Recon K-Wire into the K-Wire Inserter and attach it to the T-Handle.

The K-Wire is then manually advanced through the K-Wire Sleeve until it reaches the subchondral bone of the femoral head (Fig. 23).

Alternatively, the K-Wire Inserter can be attached to a Power Tool and the Recon K-Wire is inserted to the same depth.

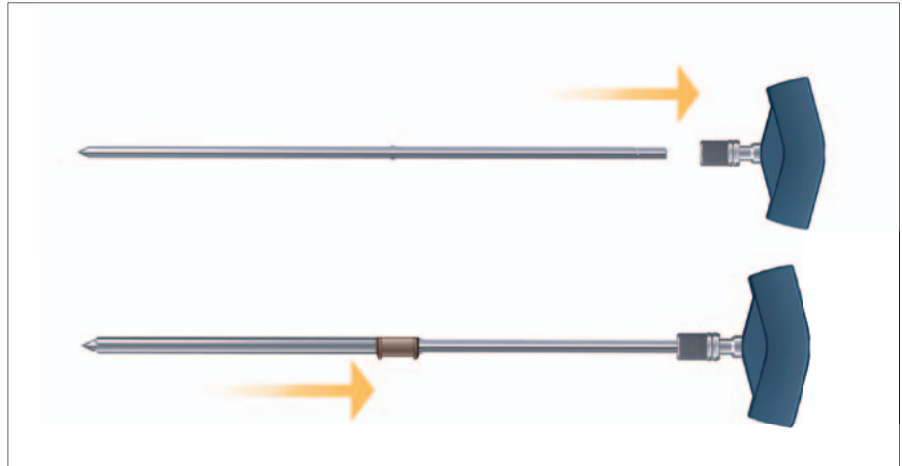

Fig. 21

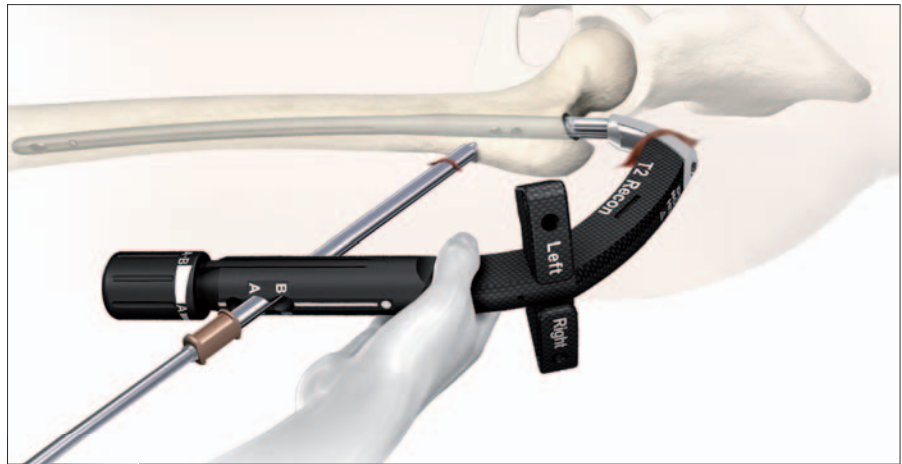

Fig. 22



Fig. 23



Operative Technique

Note:

With the image intensifier, verify if the K-Wire is placed along the calcar region in the A/P view and central on the lateral view (correct anteversion) (Fig. 24).

If the K-Wire is incorrectly positioned, the first step is to remove it and then to correct the nail position.

More commonly, the nail is positioned too proximal and correction of the nail should be carried out either by hand or by using the Strike Plate placed into the Target Device. If a higher position is required, the Universal Rod and Slotted Hammer may then be attached to the Strike Plate to carefully and smoothly extract the assembly (Fig. 25).

The new position is checked again with the image intensifier as described above.

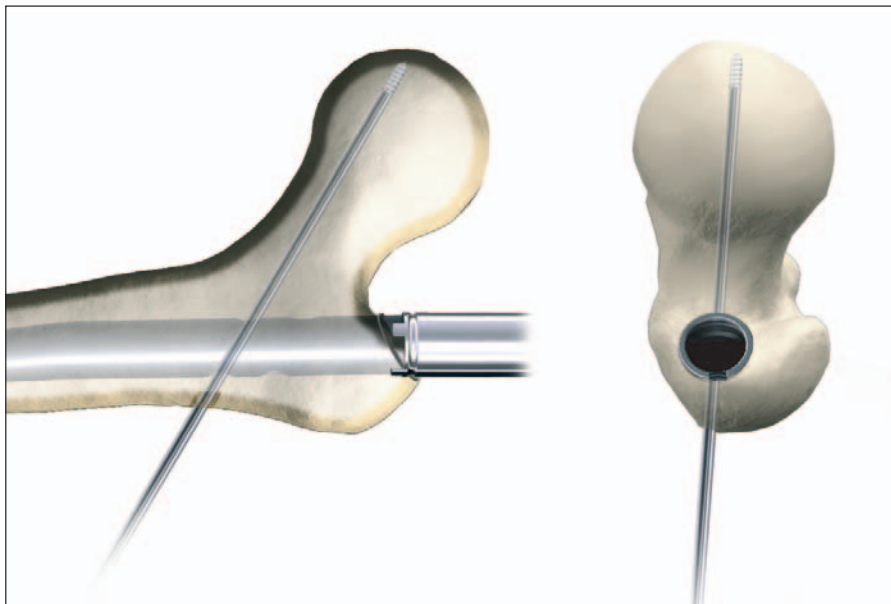

Fig. 24



Fig. 25

Operative Technique

Nail/Lag Screws Positioning with the One Shot Device

The use of the One Shot device (1213-3010) is recommended to predetermine the optimal Lag Screw placement* (Fig. 26). The One Shot Device is made of carbon fiber and works by providing a target to indicate the position of the K-Wire on the fluoroscope screen. The target contains 3 radio-opaque wires embedded in the arm – a dashed inner wire and two solid outer wires. These wires work like a gun sight to indicate the position of the K-Wire.

The One Shot Device is attached by slightly pressing the grip and releasing it when positioned onto the Tissue Protection Sleeve. To correct the position or remove the device, the grip must be pressed.

Note:

The use of the One Shot Device should not replace any steps in the T2 Recon Operative Technique.

While pressing the attachment grip, the device is positioned between the anterior aspect of the patient's hip and the fluoroscope screen positioned for an A/P view of the hip (Fig. 26, 27).

Note:

It is important to drape the patient so that the One Shot Device does not interfere with any drapes anterior to the patient's hip.

When positioned correctly, the target will appear in the fluoroscopic image (A/P view) with the dashed inner wire in the middle of the two solid outer wires (Fig. 27). If it does not, the One Shot Device should be moved towards or away from the patient by pressing the grip slightly until the target is seen as described above.

* Tokunaga et al, Correct lag screw positioning for the Gamma Nail: Development for the targeting device for insertion, Osteo Trauma Care 2005; 13:14-17



Fig. 26

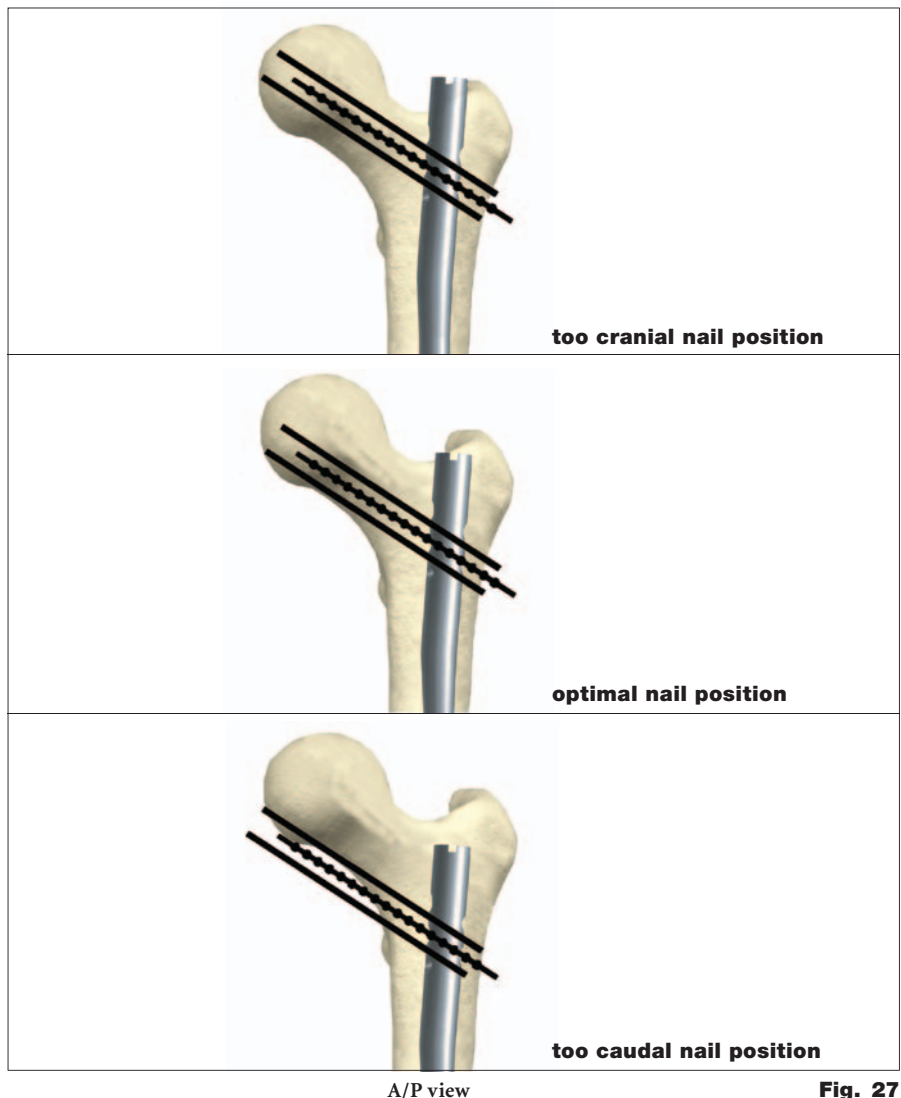

Fig. 27

Operative Technique

To identify the accurate position, the dashed wire of the target must appear between the two solid wires at the desired position. If the position is incorrect the T2 Recon Nail position may be corrected by either pulling backwards or pushing forwards (Fig. 28).

The K-Wire can then be placed into the femur and the targeting arm is held in place until the K-Wire's position in the lateral view has been determined. When positioned correctly, the target will appear in the fluoroscopic lateral view (Fig. 29).

If the dashed wire of the target appears between the two solid wires, then advance the Recon Tissue Protection Sleeve and Trocar as shown in Fig. 21.

Warning:

Prior to advancing the K-Wire, check the correct guidance through the K-Wire Sleeve. Do not use bent K-Wires.

Note:

The K-Wire inserted into the most distal Lag Screw hole of the nail helps in achieving the correct positioning of the nail (depth and rotation) with minimal resection of bone in case correction of the position is needed.



Fig. 28

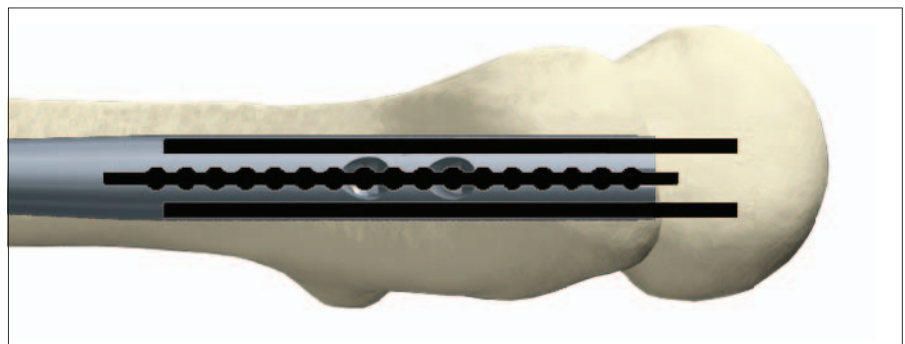

Lateral view

Fig. 29

Operative Technique

Solid Stepdrill Technique

For the insertion of proximal screws in Recon Mode, the Solid Stepdrill Technique, which is mentioned in this chapter, is the recommended method to optimize the proximal targeting accuracy.

Attach the Recon Paddle Trocar to the T-Handle, AO Medium Coupling as demonstrated in Fig. 21. Then slide the Tissue Protection Sleeve together with the Paddle Trocar assembly to the skin through the proximal target hole labeled (B).

A small skin incision is made and the assembly is pushed through until it is in contact with the lateral cortex. When the tip of the sleeve is in contact with the lateral cortex, lock the sleeve by turning the knob further to the position labeled (A+B) (Fig. 30).

Then remove the Trocar assembly and insert the Drill Sleeve for the Recon Solid Stepdrill while the distal K-Wire and K-Wire Sleeve are still left in place. The Drill Sleeve for the Recon Solid Stepdrill is inserted through the proximal target hole labeled (B) of the Targeting Device. The Ø6.5mm Solid Stepdrill for Recon Lag Screw is forwarded through the Tissue Protection Sleeve and Drill Sleeve assembly and pushed onto the lateral cortex. There is a dedicated Drill Sleeve for the Solid Stepdrill Technique. This Sleeve is marked "Use with Solid Step Drill" as shown (Fig. 31b).

Reaming is performed under fluoroscopic control just until the tip of the Solid Stepdrill for Lag Screw reaches the subchondral bone. The required length of the Lag Screw can be read directly off the Recon Solid Stepdrill for Lag Screw at the end of the Drill Sleeve (Fig. 31a).



Fig. 30

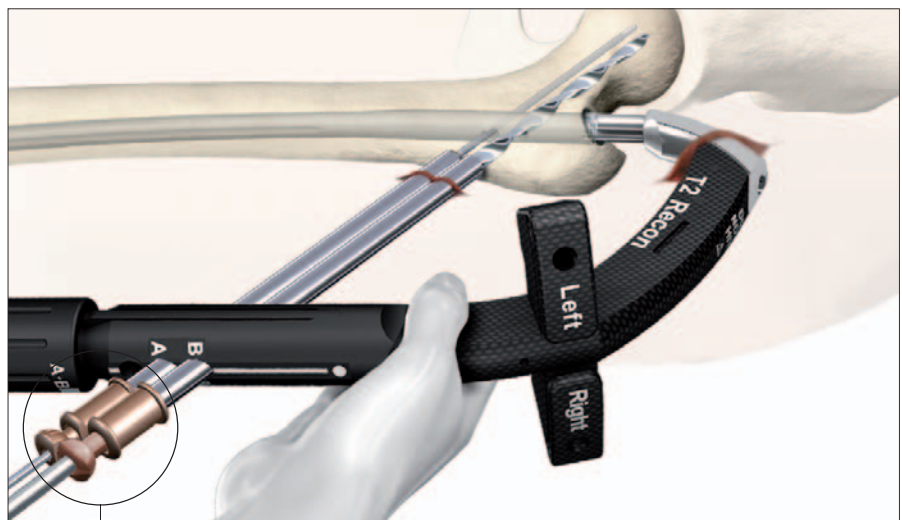

Fig. 31

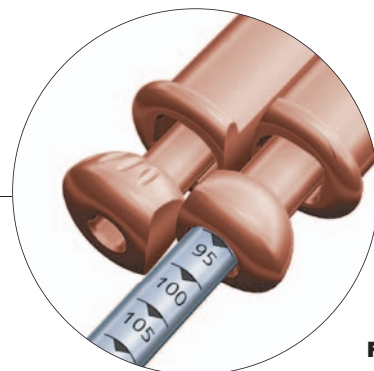

Fig. 31a



Fig. 31b

Operative Technique

Using the Recon Screwdriver the correct Lag Screw is inserted through the Tissue Protection Sleeve and threaded up to the subcondral part of the femoral head. The screw is near its proper seating position when the groove around the shaft of the screwdriver is approaching the end of the Tissue Protection Sleeve (Fig. 32, 32a). The required length of the second Lag Screw can be measured using the Recon Lag Screw Gauge.

Remove the Distal K-Wire and K-Wire Sleeve. Then insert the Sleeve for the solid Stepdrill into the distal Tissue Protection Sleeve.

Repeat the same surgical steps for drilling and insertion of the distal Lag Screw without K-Wire guidance.

After the completion of the distal Lag Screw insertion, move on to the distal locking procedure.

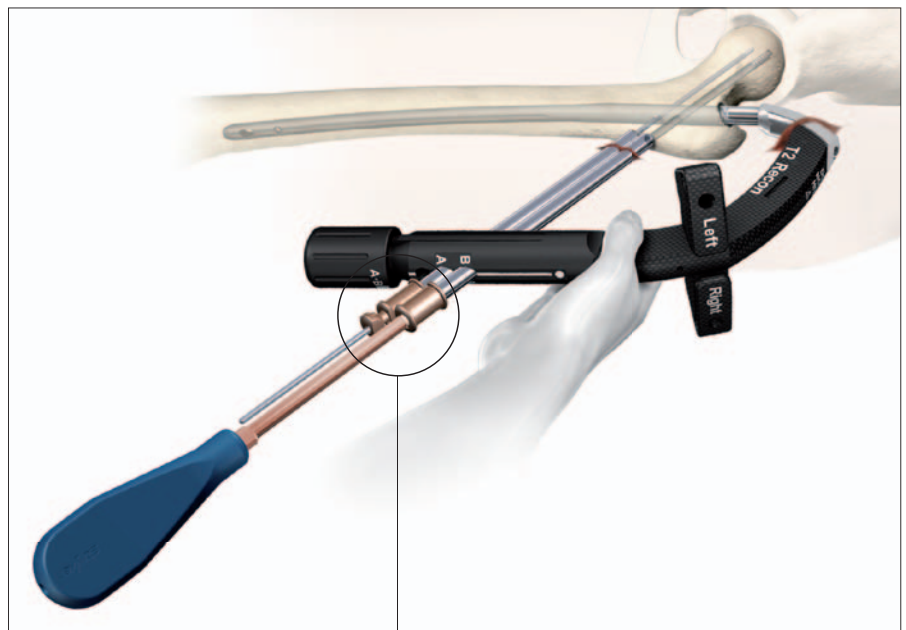

Fig. 32

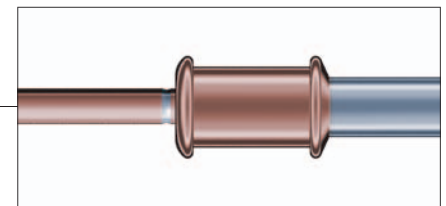

Fig. 32a

Operative Technique

Alternatively, the K-Wire can be used prior to drilling with the Solid Drill.

Place a second Recon K-Wire into the K-Wire Inserter and attach it to the T-Handle or power tool. The K-Wire is then advanced through the K-Wire Sleeve until it reaches the subchondral bone of the femoral head.

Warning:

Correct placement of the K-Wire tip in subchondral bone must be checked with image intensifier in both A/P and M/L views.

The required length of the Lag Screw is measured using the Recon Lag Screw Gauge.

Note:

Before starting to measure, ensure that the Tissue Protection Sleeve and K-Wire Sleeve assembly is firmly pressed against the lateral cortex of the femur (Fig. 32b).

Take the Recon Lag Screw Gauge and place it directly under the K-Wire and against the K-Wire Sleeve (Fig. 32c). The correct Lag Screw length corresponds to the measurement indicated at the end of the K-Wire on the Lag Screw Gauge.

After the measurement, remove the K-Wire and drill the channel with the Solid Stepdrill according to the Solid Stepdrill technique described on page 22.

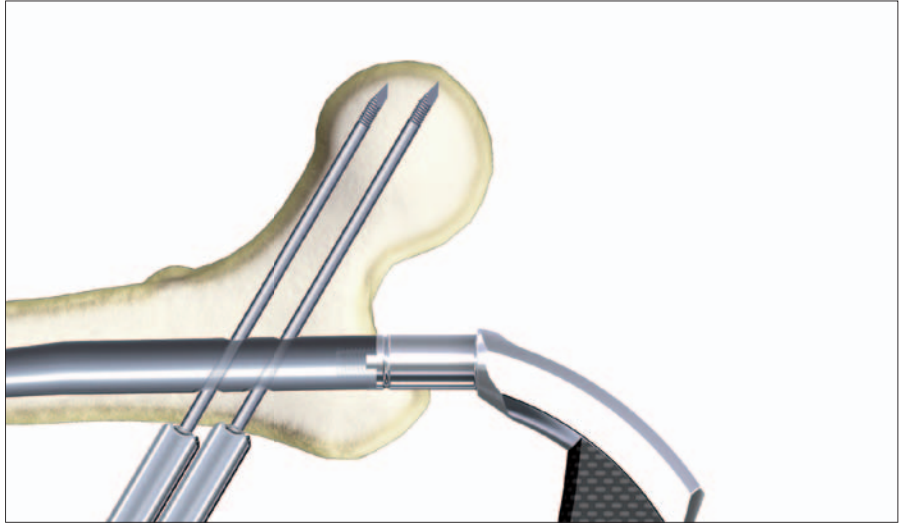
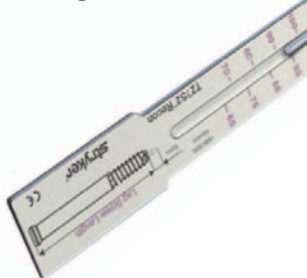

Fig. 32b



Fig. 32c



Operative Technique

Cannulated Stepdrill Technique

As the Cannulated Stepdrill technique was also discussed in a previous version of the operative technique, the insertion of the proximal screws in Recon Mode using this method will also be mentioned as a potential option.

After achieving a satisfactory position of the first Recon K-Wire slide the second Recon Tissue Protection Sleeve together with the Recon K-Wire Sleeve into the proximal target hole on the Targeting Arm, labeled (B). A small skin incision is made and the assembly is pushed through until it is in contact with the lateral cortex (Fig. 33).

Place a second Recon K-Wire into the K-Wire Inserter and attach it to the T-Handle or power tool. The K-Wire is then advanced through the K-Wire Sleeve until it penetrates the subchondral bone of the femoral head.

Caution:

Correct placement of the K-Wire tip in subchondral bone must be checked with image intensifier in both A/P and M/L views.

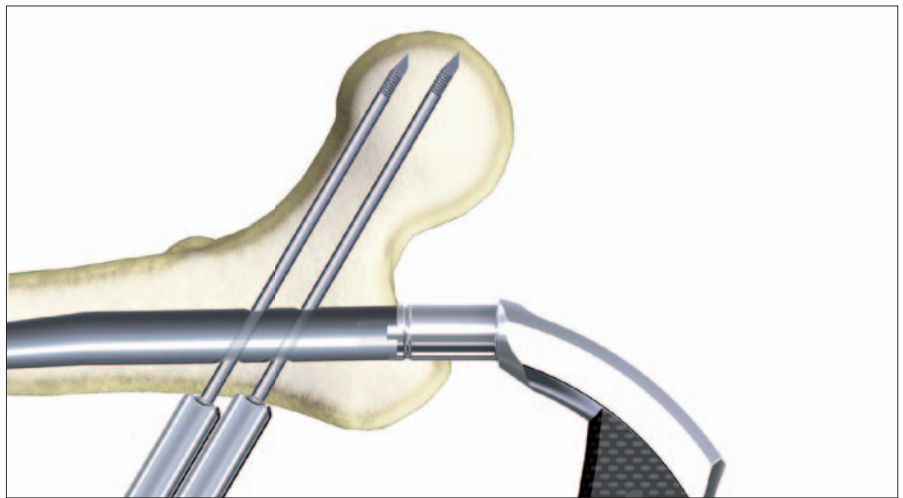

Fig. 33

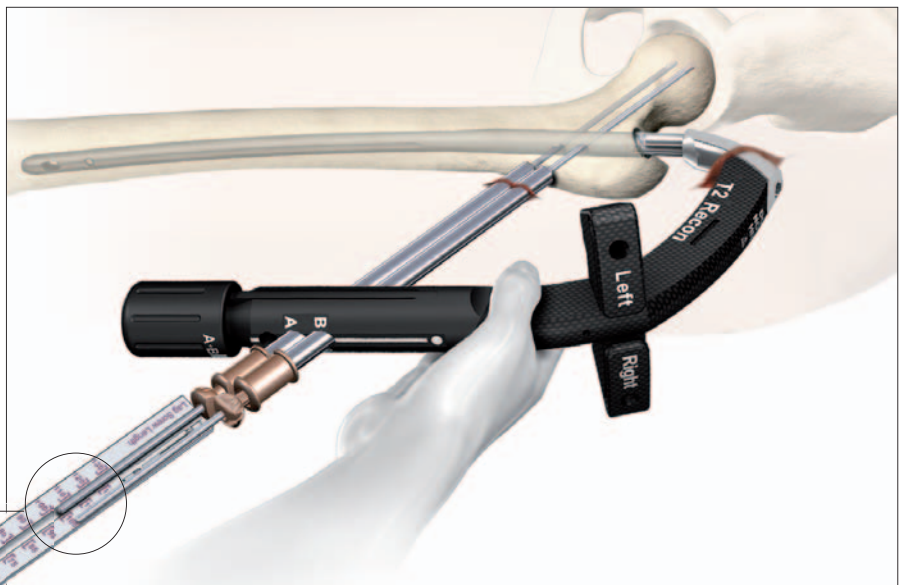

Fig. 34

The required length of the Lag Screw is measured using the Recon Lag Screw Gauge (1806-3035). Before starting to measure, ensure that the Tissue Protection Sleeve and K-Wire Sleeve assembly is firmly pressed against the lateral cortex of the femur. Take the Recon Lag Screw Gauge and place it directly under the distal K-Wire and against the K-Wire Sleeve (Fig. 34).

The correct Lag Screw length corresponds to the measurement indicated at the end of the K-Wire on the Lag Screw Gauge. This length will then be set on the cannulated Recon Stepdrill for Lag Screw (Fig. 35).

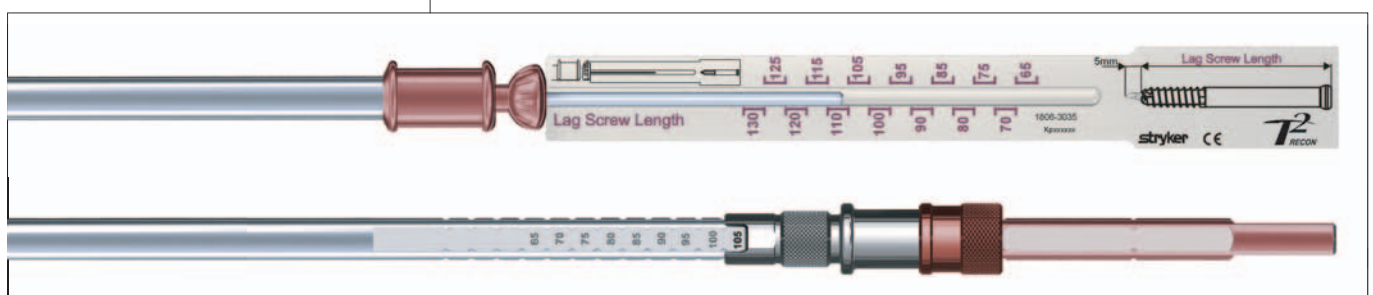

Fig. 35

Operative Technique

Caution:

Before proceeding with drilling for the selected Lag Screw, check the A/P fluoroscopic views to see if the two Recon K-Wires are parallel.

The distal K-Wire Sleeve is removed while the Tissue Protection Sleeve remains in position (Fig. 36a). The cannulated Ø6.5mm Recon Stepdrill for Lag Screw (REF 1806-3025) is forwarded through the Tissue Protection Sleeve and pushed onto the lateral cortex. The stop on the drill will only allow drilling up to 5mm before the K-Wire ends (Fig. 36b).

Warning:

Do not use the cannulated Recon Stepdrill for Lag Screw over a deflected K-Wire.

Using the Recon Screwdriver, the selected Lag Screw is inserted through the Tissue Protection Sleeve and threaded up to the subchondral bone of the femoral head. The screw is near its proper seating position when the groove around the shaft of the screwdriver is approaching the end of the Tissue Protection Sleeve (Fig. 37).

Alternatively, the Recon Screwdriver Shaft may be assembled into the T-Handle and used for the Lag Screw insertion.

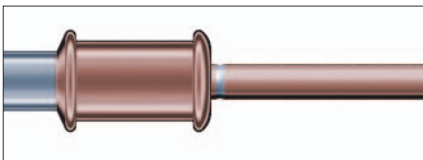

The required length of the second Lag Screw is measured using the Recon Lag Screw Gauge. Repeat the same surgical steps for drilling and insertion of the proximal Lag Screw (Fig. 38).

After the completion of the distal Lag Screw insertion, move on to the proximal locking procedure.

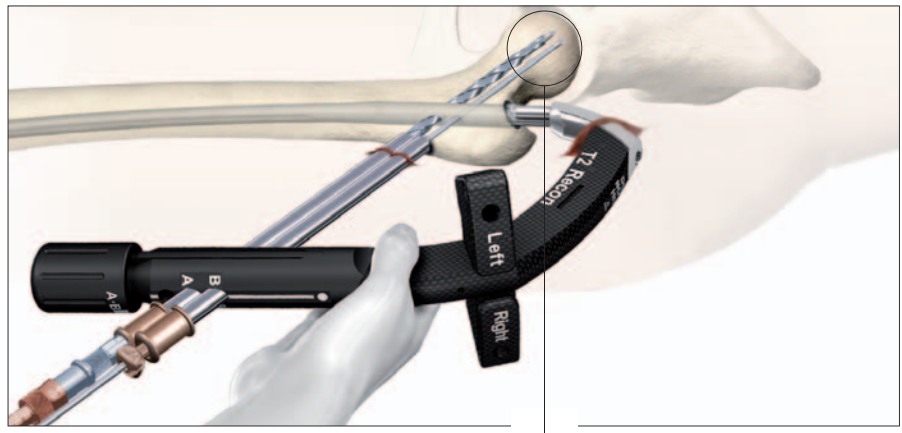

Fig. 36a

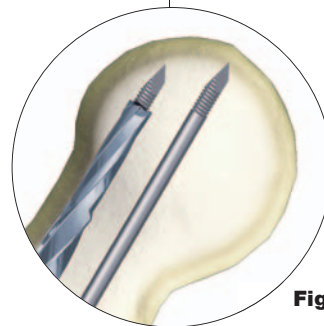

Fig. 36b



Fig. 37

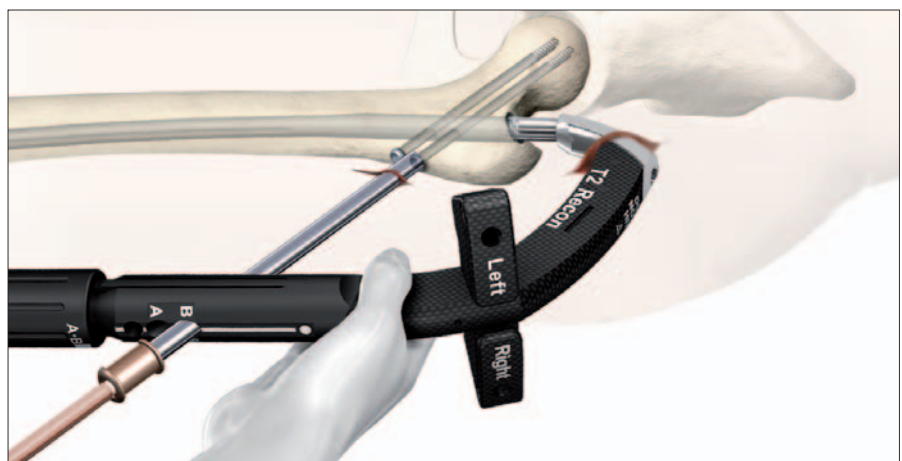

Fig. 38

Operative Technique

Pre-drilling the lateral cortex

Pre-drilling opens the lateral cortex for the drill entry. Pre-drilling helps to prevent a possible slipping of the drill on the cortex and may avoid deflection within the cancellous bone.

The Paddle Trocar Assembly is then removed and the Drill Sleeve is inserted through the Long Tissue Protection Sleeve (Fig. 42). With the Long Tissue Protection Sleeve firmly engaged in the cortex, the lateral cortex should be opened using the centered tip green coded 4.2mm Drill.

The Drill can be connected with the AO Teardrop Handle Coupling allowing pre-drilling by hand (Fig. 43). It also can be done using power.

Note:

For optimal stability, the tip of the oblique screw should be positioned at the level of the lesser trochanter (Fig. 44).

Then use the center-tipped, calibrated $\text{Ø}4.2 \times 340\text{mm}$ Drill and drill through both cortices (Fig. 45).

The screw length may be read directly from the Calibrated Drill at the end of the Drill Sleeve (Fig. 45a).

Caution:

Start the drill before touching the bone and then keep a gentle pressure on the pre-drilled cortex to ensure accurate drilling.

Note:

The position of the drill end, as it relates to the far cortex, is the same position where the screw will end.

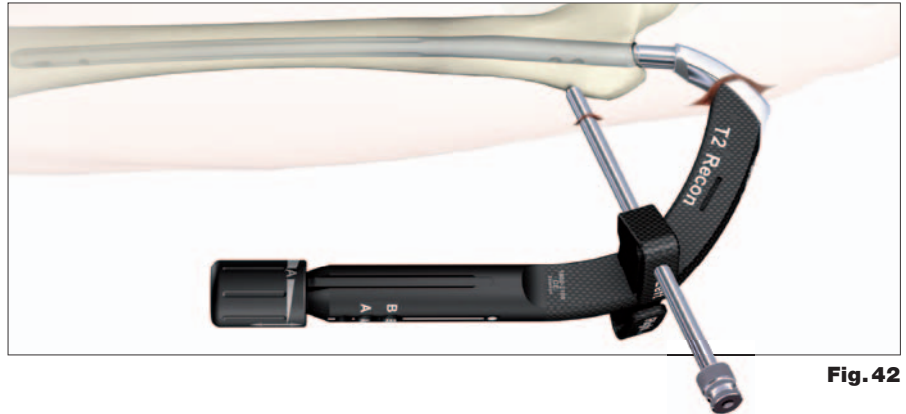

Fig. 42

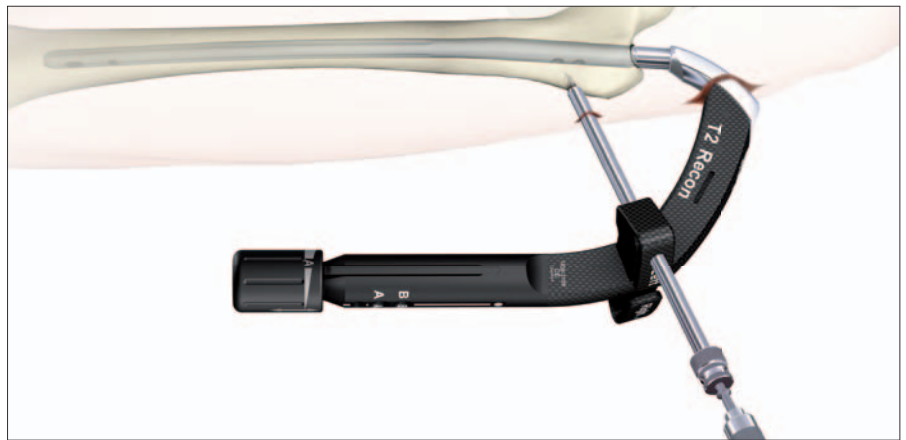

Fig. 43

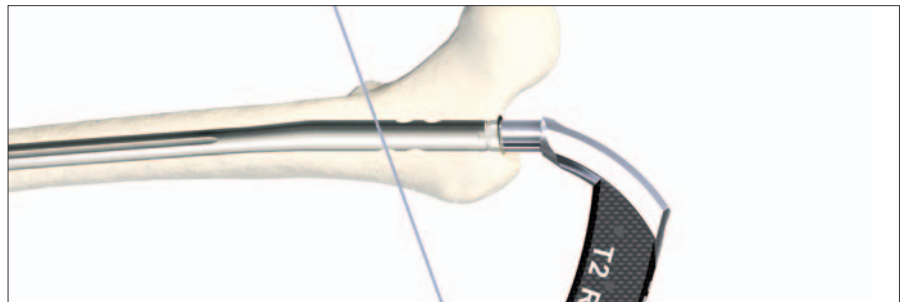

Fig. 44



Fig. 45



Fig. 45a

Operative Technique

Therefore, if the end of the Drill is 3mm beyond the far cortex, the end of the screw will also be 3mm beyond (Fig. 46). **Check the position of the end of the Drill with image intensification before measuring the screw length.** If the screw measurement using the Long Screw Gauge is preferred, first remove the Long Drill Sleeve and read the screw length directly at the end of the Long Tissue Protection Sleeve.

Note:

- Before starting to measure, ensure that the Tissue Protection Sleeve/Drill Sleeve Assembly and K-Wire Sleeve assembly is firmly pressed against the lateral cortex of the femur (Fig. 46, 47).
- The Long Screw Gauge is calibrated so that with the bend at the end pulled back flush with the far cortex, the screw tip will end 3mm beyond the far cortex (Fig. 47).

When the Drill Sleeve is removed, the correct Locking Screw is inserted through the Tissue Protection Sleeve using the Long Screwdriver Shaft with Teardrop Handle (Fig. 48). The screw is advanced through both cortices. The screw is near its proper seating position when the groove around the shaft of the screwdriver is approaching the end of the Tissue Protection Sleeve (Fig. 48a).



Fig. 46



Fig. 47



Fig. 48

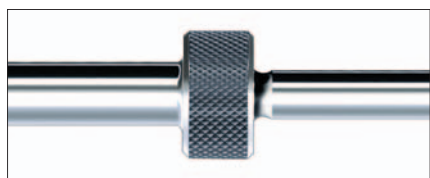

Fig. 48a

Operative Technique

Freehand Distal Locking

The freehand technique is used to insert Fully Threaded Locking Screws into both distal transverse holes in the nail.

Rotational alignment must be checked prior to locking the nail. This is performed by checking a lateral view at the hip and a lateral view at the knee. The anteversion should be the same as on the contralateral side.

Multiple locking techniques and radiolucent drill devices are available for freehand locking. The critical step with any freehand locking technique, proximal or distal, is to visualize a perfectly round locking hole with the C-Arm.

The center-tipped $\text{ø}4.2 \times 180\text{mm}$ Drill is held at an oblique angle to the center of the locking hole (Fig. 49). Upon X-Ray verification, the Drill is placed perpendicular to the nail and drilled through the lateral and medial cortices (Fig. 50). Confirm in both the A/P and lateral views by X-Ray that the Drill passes through the hole in the nail.

After drilling both cortices, the screw length may be read directly off of the Long Screw Scale at the green ring on the center-tipped $\text{ø}4.2 \times 180\text{mm}$ Drill (Fig. 51).

Alternatively, the Screw Gauge for freehand technique can be used instead of the Long Screw Scale to determine the screw length.

Routine Locking Screw insertion is employed with the assembled Long Screwdriver Shaft and Teardrop Handle.

Note:

The Screwdriver Shaft can be used in conjunction with the Long Screw Capture Sleeve.

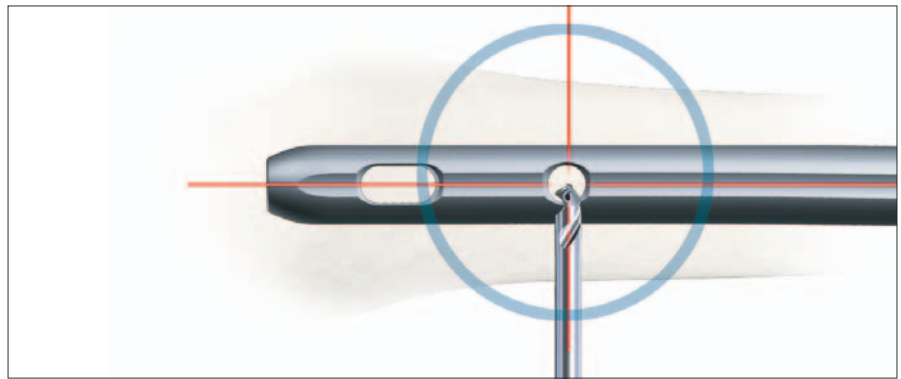

Fig. 49

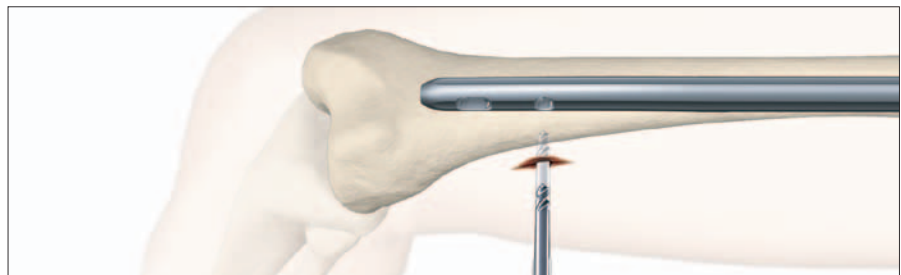

Fig. 50

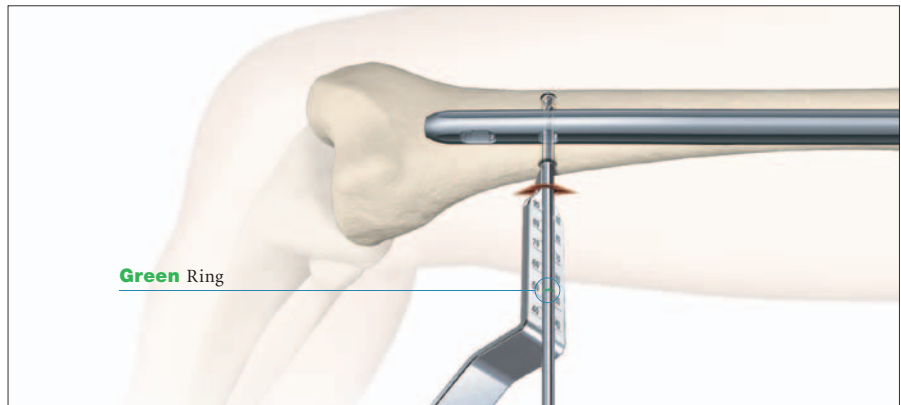

Fig. 51

Operative Technique

Repeat the locking procedure for the insertion of the second 5mm Fully Threaded Locking Screw into the oblong hole in a static position (Fig. 52).

The **T2 Recon Nail** may be used in the **dynamic locking mode**. When the fracture pattern permits, dynamic locking may be utilized for transverse, rotationally stable fractures. While dynamic locking can only be performed at the end of the nail, this will require a freehand distal targeting of the oblong hole in a dynamic position. This allows the nail to move and the fracture to settle while torsional stability is maintained.

Note:

As an alternative for distal locking, the guided distal targeting system can be used. For details, please refer to the separate operative techniques (Distal Targeting System Gamma3 Long Nail R1.5, T2 Recon nail R1.5) or ask Stryker Representative for further assistance.

Release the Nail Holding Screw using the Screwdriver Shaft, Ball Tip and T-Handle. Then remove the Targeting Arm to complete surgery.

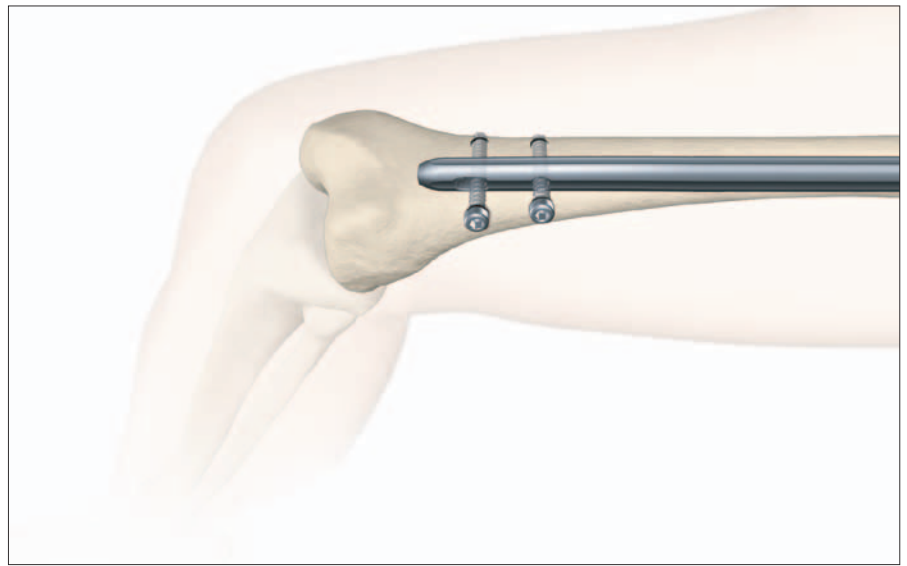

Fig. 52

Operative Technique

Set Screw or End Cap Insertion

After removal of the Target Device, a Set Screw or End Cap can be used.

Two different Set Screws are available (Fig. 53a):

- a **Recon Set Screw** to tighten down on the Proximal Lag Screw for the Recon Mode
- an **Antegrade Set Screw** to tighten down on the oblique Fully Threaded Screw for the Femoral Antegrade Mode

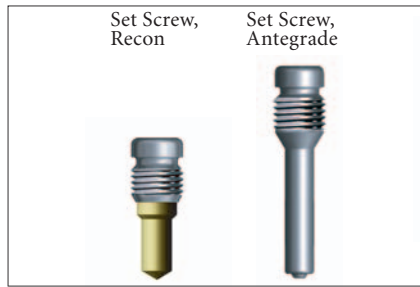

Fig. 53a



Fig. 53b

Note:

If a Set Screw is used, an End Cap can no longer be inserted.

Four different sizes of End Caps are available to adjust nail length and to reduce the potential for bony ingrowth into the proximal thread of the nail (Fig. 53b).

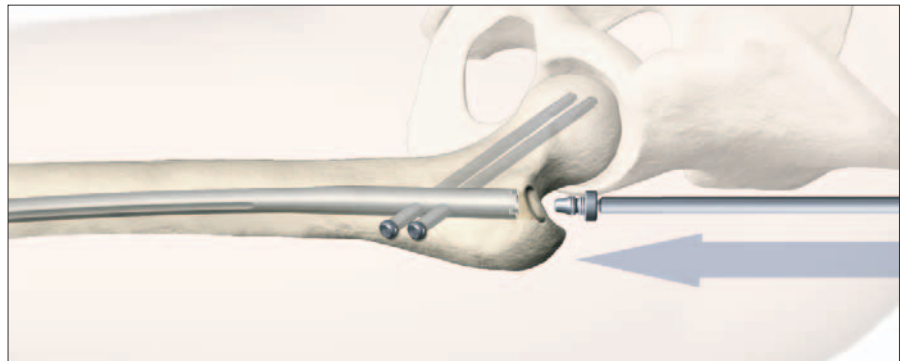

Fig. 54

The Set Screw or End Cap is inserted with the Long Screwdriver Shaft and Teardrop Handle after intra-operative radiographs confirm satisfactory reduction and hardware implantation (Fig. 54). Be sure to fully seat the End Cap or Set Screw to minimize the potential risk for loosening.

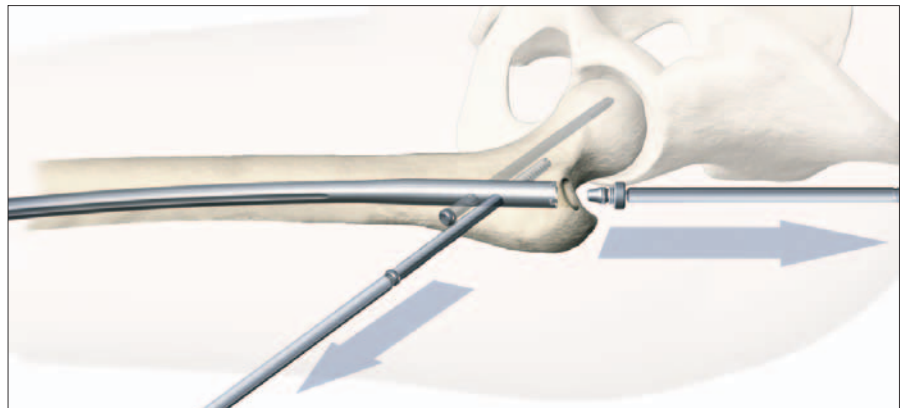

Fig. 55

Nail Removal

The Set Screw or End Cap is removed with the Long Screwdriver Shaft and Teardrop Handle (Fig. 55).

The Universal Rod is inserted into the driving end of the nail. Alternatively, the Conical Extraction Rod, can be attached to the Universal Rod to facilitate extraction of the nail. All 5mm Fully Threaded Locking Screws are removed with the Screwdriver, Selfholding. The optional Long Screw Capture Sleeve may be used on the Screwdriver Shaft. For removal of the Lag Screws, the Recon Screwdriver or the Recon Screwdriver Shaft and T-Handle are to be used.

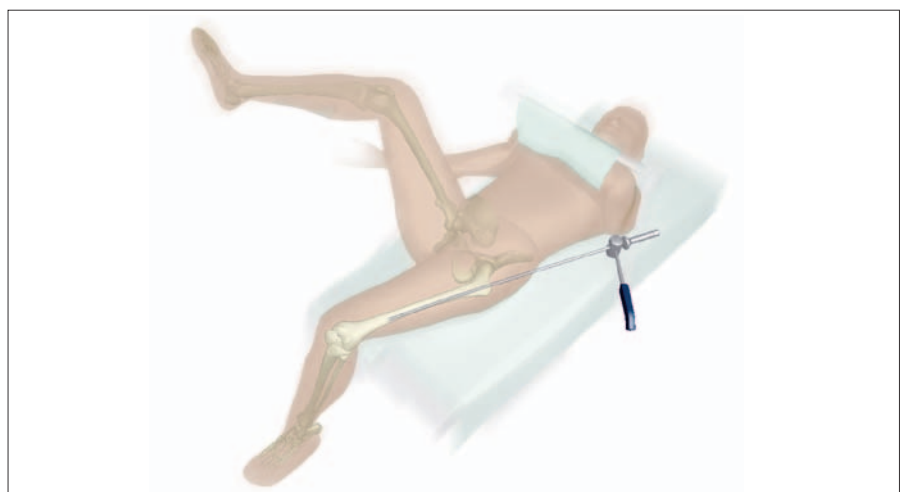



Fig. 56

The Slotted Hammer is used to extract the nail in a controlled manner (Fig. 56).

Ordering Information – Implants

T2 Recon Nail R1.5, Left



Titanium REF	Diameter mm	Length mm
1843-0926S	9.0	260
1843-0928S	9.0	280
1843-0930S	9.0	300
1843-0932S	9.0	320
1843-0934S	9.0	340
1843-0936S	9.0	360
1843-0938S	9.0	380
1843-0940S	9.0	400
1843-0942S	9.0	420
1843-0944S	9.0	440
1843-0946S	9.0	460
1843-0948S	9.0	480
1843-1026S	10.0	260
1843-1028S	10.0	280
1843-1030S	10.0	300
1843-1032S	10.0	320
1843-1034S	10.0	340
1843-1036S	10.0	360
1843-1038S	10.0	380
1843-1040S	10.0	400
1843-1042S	10.0	420
1843-1044S	10.0	440
1843-1046S	10.0	460
1843-1048S	10.0	480
1843-1126S	11.0	260
1843-1128S	11.0	280
1843-1130S	11.0	300
1843-1132S	11.0	320
1843-1134S	11.0	340
1843-1136S	11.0	360
1843-1138S	11.0	380
1843-1140S	11.0	400
1843-1142S	11.0	420
1843-1144S	11.0	440
1843-1146S	11.0	460
1843-1148S	11.0	480
1843-1226S	12.0	260
1843-1228S	12.0	280
1843-1230S	12.0	300
1843-1232S	12.0	320
1843-1234S	12.0	340
1843-1236S	12.0	360
1843-1238S	12.0	380
1843-1240S	12.0	400
1843-1242S	12.0	420
1843-1244S	12.0	440
1843-1246S	12.0	460
1843-1248S	12.0	480
1843-1326S	13.0	260
1843-1328S	13.0	280
1843-1330S	13.0	300
1843-1332S	13.0	320
1843-1334S	13.0	340
1843-1336S	13.0	360
1843-1338S	13.0	380
1843-1340S	13.0	400
1843-1342S	13.0	420
1843-1344S	13.0	440
1843-1346S	13.0	460
1843-1348S	13.0	480
1843-1526S	15.0	260
1843-1528S	15.0	280
1843-1530S	15.0	300
1843-1532S	15.0	320
1843-1534S	15.0	340
1843-1536S	15.0	360
1843-1538S	15.0	380
1843-1540S	15.0	400
1843-1542S	15.0	420
1843-1544S	15.0	440
1843-1546S	15.0	460
1843-1548S	15.0	480

T2 Recon Nail R1.5, Right



Titanium REF	Diameter mm	Length mm
1845-0926S	9.0	260
1845-0928S	9.0	280
1845-0930S	9.0	300
1845-0932S	9.0	320
1845-0934S	9.0	340
1845-0936S	9.0	360
1845-0938S	9.0	380
1845-0940S	9.0	400
1845-0942S	9.0	420
1845-0944S	9.0	440
1845-0946S	9.0	460
1845-0948S	9.0	480
1845-1026S	10.0	260
1845-1028S	10.0	280
1845-1030S	10.0	300
1845-1032S	10.0	320
1845-1034S	10.0	340
1845-1036S	10.0	360
1845-1038S	10.0	380
1845-1040S	10.0	400
1845-1042S	10.0	420
1845-1044S	10.0	440
1845-1046S	10.0	460
1845-1048S	10.0	480
1845-1126S	11.0	260
1845-1128S	11.0	280
1845-1130S	11.0	300
1845-1132S	11.0	320
1845-1134S	11.0	340
1845-1136S	11.0	360
1845-1138S	11.0	380
1845-1140S	11.0	400
1845-1142S	11.0	420
1845-1144S	11.0	440
1845-1146S	11.0	460
1845-1148S	11.0	480
1845-1226S	12.0	260
1845-1228S	12.0	280
1845-1230S	12.0	300
1845-1232S	12.0	320
1845-1234S	12.0	340
1845-1236S	12.0	360
1845-1238S	12.0	380
1845-1240S	12.0	400
1845-1242S	12.0	420
1845-1244S	12.0	440
1845-1246S	12.0	460
1845-1248S	12.0	480
1845-1326S	13.0	260
1845-1328S	13.0	280
1845-1330S	13.0	300
1845-1332S	13.0	320
1845-1334S	13.0	340
1845-1336S	13.0	360
1845-1338S	13.0	380
1845-1340S	13.0	400
1845-1342S	13.0	420
1845-1344S	13.0	440
1845-1346S	13.0	460
1845-1348S	13.0	480
1845-1526S	15.0	260
1845-1528S	15.0	280
1845-1530S	15.0	300
1845-1532S	15.0	320
1845-1534S	15.0	340
1845-1536S	15.0	360
1845-1538S	15.0	380
1845-1540S	15.0	400
1845-1542S	15.0	420
1845-1544S	15.0	440
1845-1546S	15.0	460
1845-1548S	15.0	480

Note:

Check with your local representative regarding availability of nail sizes.

Ordering Information – Implants

6.5mm Lag Screws



Titanium REF	Diameter mm	Length mm
1897-6065S	6.5	65
1897-6070S	6.5	70
1897-6075S	6.5	75
1897-6080S	6.5	80
1897-6085S	6.5	85
1897-6090S	6.5	90
1897-6095S	6.5	95
1897-6100S	6.5	100
1897-6105S	6.5	105
1897-6110S	6.5	110
1897-6115S	6.5	115
1897-6120S	6.5	120
1897-6125S	6.5	125
1897-6130S	6.5	130

5mm Fully Threaded Locking Screws



Titanium REF	Diameter mm	Length mm
1896-5025S	5.0	25.0
1896-5030S	5.0	30.0
1896-5035S	5.0	35.0
1896-5040S	5.0	40.0
1896-5045S	5.0	45.0
1896-5050S	5.0	50.0
1896-5055S	5.0	55.0
1896-5060S	5.0	60.0
1896-5065S	5.0	65.0
1896-5070S	5.0	70.0
1896-5075S	5.0	75.0
1896-5080S	5.0	80.0
1896-5085S	5.0	85.0
1896-5090S	5.0	90.0
1896-5095S	5.0	95.0
1896-5100S	5.0	100.0
1896-5105S	5.0	105.0
1896-5110S	5.0	110.0
1896-5115S	5.0	115.0
1896-5120S	5.0	120.0

End Caps



Titanium REF	Diameter mm	Length mm
1822-0003S	8.0	Standard
1847-0005S	13.0	+ 5mm
1847-0010S	13.0	+10mm
1847-0015S	13.0	+15mm

Set Screws





























Titanium REF	Diameter mm	Length mm
1847-0001S	8.0	Set Screw, Recon
1847-0003S	8.0	Set Screw, Antegrade

Note:

Check with your local representative regarding availability of nail sizes.

Implants are in sterile packaging. Outside of the U.S., Locking Screws may be ordered non-sterile without the "S" at the end of the corresponding catalog number.

Ordering Information – Instruments

	REF	Description
T2 Basic Long		
	702429	Teardrop Handle, AO Coupling**
	703165	Protection Sleeve, Retrograde***
	1806-0022	Guide Wire Ruler
	1806-0032	Awl Plug
	1806-0041	Awl
	1806-0110	Universal Rod
	1806-0125	Reduction Spoon
	1806-0130	Wrench 8mm/10mm
	1806-0135	Insertion Wrench, 10mm***
	1806-0150	Strike Plate
	1806-0170	Slotted Hammer
	1806-0185	Tissue Protection Sleeve, Long
	1806-0203	Screwdriver, Self-Holding, Extra Short (3.5)
	1806-0215	Drill Sleeve, Long
	1806-0227	Screwdriver Shaft AO, Long
	1806-0233	Screwdriver, Self-Holding, Long (3.5)
	1806-0268	Screwdriver Shaft, Compression (hex3.5)***
	1806-0271	Guide Wire Pusher
	1806-0315	Trocar, Long***
	1806-0325	Screw Gauge, Long
	1806-0331	Screw Gauge (20-120mm)
	1806-0350	Extraction Rod, Conical (Ø8mm)
	1806-0365	Screw Scale, Long
	1806-1095	Guide Wire Handle
	1806-1096	Guide Wire Handle Chuck
	1806-2014	Rigid Reamer Ø12mm***
	1806-9900	T2 Basic Long Instrument Tray
	1806-9901	T2 Basic Long Instrument Set, Completely filled

****Caution:**

The coupling of Elastosil handles contains a mechanism with one or multiple ball bearings. In case of applied axial stress on the Elastosil handle, those components are pressed into the surrounding cylinder resulting in a complete blockage of the device and possible bending.

To help avoid intra-operative complications and promote long-term functionality, we mandate that Elastosil handles be used only for their intended use. DO NOT HIT them.

*** items are part of T2 Basic Long Instrument set (1806-9901); however, not used for T2 Recon Nailing surgery

Ordering Information – Instruments

REF Description

T2 Recon Instruments

	1806-3100	Target Device
	1806-3101	Knob for Target Device
	1806-3005	Nail Holding Screw, Recon
	1806-3010	One Step Conical Reamer Ø13, Recon
	1806-3015	One Step Conical Reamer Ø15, Recon
	1806-3026S	Solid Stepdrill for Lag Screw*
	1806-3030S	Recon K-Wire, Recon*
	1806-3031S	K-Wire, Recon, CoCr
	1806-3035	Lag Screw Gauge, Recon
	1806-3040	K-Wire Sleeve, Recon
	1806-3041	Drill Sleeve for Solid Stepdrill
	1806-3045	Tissue Protection Sleeve, Recon
	1806-3050	Screwdriver Shaft, Recon
	1806-3055	Multihole Trocar
	1806-3057	Protection Sleeve, Antegrade
	1806-3060	Screwdriver, Recon
	1806-3070	K-Wire Inserter
	1806-3090	Screwdriver Shaft, AO, Ball Tip
	1806-0294	Screwdriver Shaft, Selfholding, 3.5 × 85mm
	1806-4290S	Drill Ø4.2 × 230mm, AO*
	1806-4260S	Drill Ø4.2 × 340mm, AO*
	1806-4270S	Drill Ø4.2 × 180mm, AO*
	1806-8018S	Drill Ø4.2 × 250mm, oblique AO*

* For non-sterile, leave "S" off the REF number when ordering.

Ordering Information – Instruments

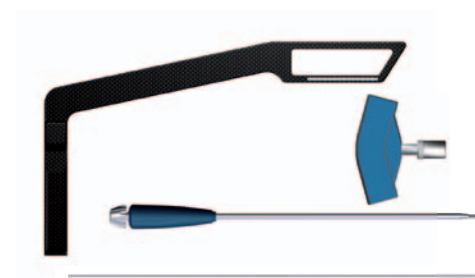

REF	Description
T2 Recon Instruments	
1213-3010	One Shot Device
702628	T-Handle, AO Medium Coupling**
1806-3065	Extraction Screwdriver
1806-0085S	Guide Wire, Ball Tip, Ø3 × 1000mm, sterile*
1806-3047	T2 Paddle Trocar Recon Mode
1806-3048	T2 Paddle Trocar Antegrade Mode
1806-3080	X-Ray Template, Recon
1806-9990	T2 Recon Instrument Tray
1806-9991	T2 Recon Instrument Set, completely filled

REF	Description
Optional Instruments	
1806-0040	Awl, Curved
1806-3025	Stepdrill for Lag Screw, Recon
1806-0240	Screw Capture Sleeve, Long
1806-0292	Screwdriver Shaft, 3.5 x 85mm
1806-0480	Screw Gauge, Femur

REF	Description
Spare Parts	
1806-9993	T2 Recon Instrument Tray Insert
1806-9992	T2 Recon Silicone Mat Free Space
1806-9995	T2 Recon Drill Rack
1806-9996	T2 Recon Insert for Reamer Heads****
1320-5375	DTS Tray Calibration Stand

* For non-sterile, leave “S” off the REF number when ordering.

****Caution:**

The coupling of Elastosil handles contains a mechanism with one or multiple ball bearings. In case of applied axial stress on the Elastosil handle, those components are pressed into the surrounding cylinder resulting in a complete blockage of the device and possible bending.

To help avoid intra-operative complications and promote long-term functionality, we mandate that Elastosil handles be used only for their intended use. DO NOT HIT them.

**** Bixcut Modular Head 9, 10, 11, 12, 13, 14, 15, 16, 17 and 2 additional Modular Heads can be stored. See page 37 for details.

Ordering Information – Instruments

Bixcut

Complete range of modular and fixed-head reamers to match surgeon preference and optimize O. R. efficiency, presented in fully sterilizable cases.

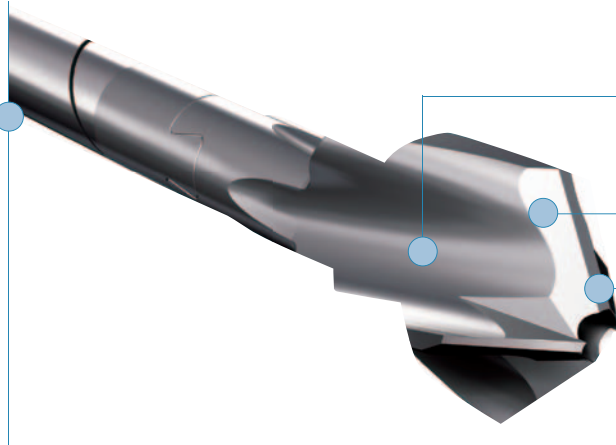

Large clearance rate resulting from reduced number of reamer blades coupled with reduced length of reamer head to allow for effective relief of pressure and efficient removal of material³.

Cutting flute geometry optimized to lower pressure generation³.

Forward- and side-cutting face combination produces efficient material removal and rapid clearance³.

Double-wound shaft transmits torque effectively and with high reliability. Low-friction surface finish aids rapid debris clearance³.

Smaller, 6 and 8mm shaft diameters are designed to reduce IM pressure.

Typical Standard Reamer Ø14mm

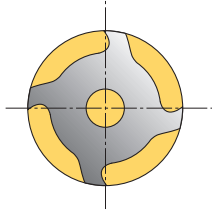

Clearance area:
32% of cross section

Bixcut Reamer Ø14mm

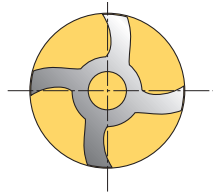

Clearance area:
59% of cross section

Studies¹ have demonstrated that the pressures developed within the medullary cavity through the introduction of unreamed IMnails can be far greater than those developed during reaming – but this depends very much upon the design of the reamer.

After a three year development study² involving several universities, the factors that determine the pressures and temperatures developed during reaming were clearly established. These factors were applied to the development of advanced reamers that demonstrate significantly better performance than the best of previous designs³.

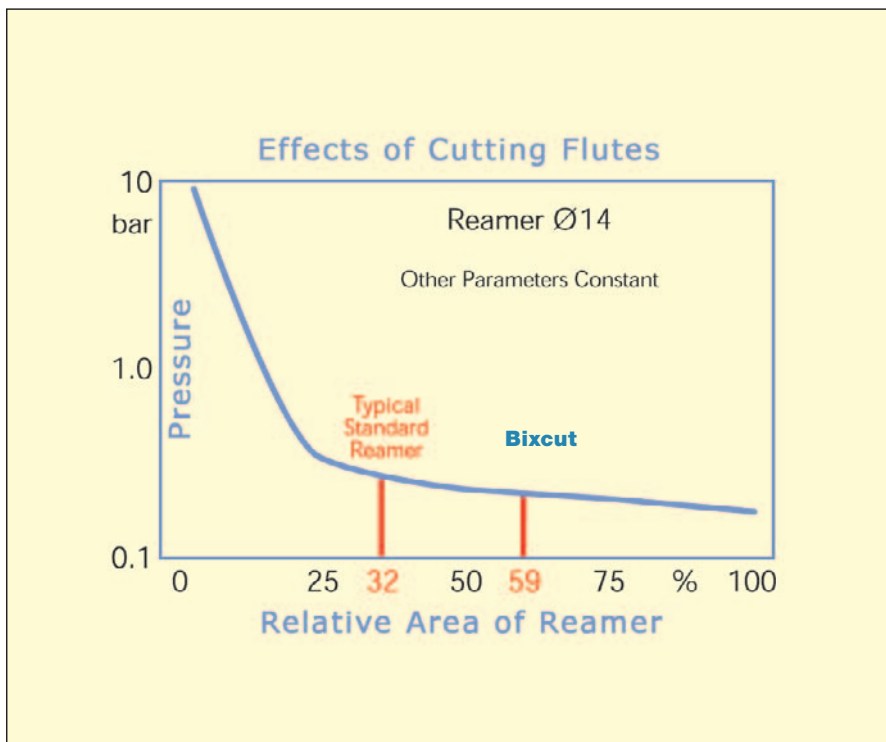

¹ Jan Paul M. Frolke, et al.; Intramedullary Pressure in Reamed Femoral Nailing with Two Different Reamer Designs, Eur. J. of Trauma, 2001 #5

² Medhi Moussavi, et al.; Pressure Changes During Reaming with Different Parameters and Reamer Designs, Clinical Orthopaedics and Related Research Number 373, pp. 295-303, 2000

³ Andreas Speitling; Intramedullary Reamers, commented slides of internal test report, Sep 1999

Ordering Information – Instruments

BIXCUT MODULAR HEAD

REF	Description	Diameter mm
0226-3090	Bixcut Head	9.0
0226-3095	Bixcut Head	9.5
0226-3100	Bixcut Head	10.0
0226-3105	Bixcut Head	10.5
0226-3110	Bixcut Head	11.0
0226-3115	Bixcut Head	11.5
0226-3120	Bixcut Head	12.0
0226-3125	Bixcut Head	12.5
0226-3130	Bixcut Head	13.0
0226-3135	Bixcut Head	13.5
0226-3140	Bixcut Head	14.0
0226-3145	Bixcut Head	14.5
0226-3150	Bixcut Head	15.0
0226-3155	Bixcut Head	15.5
0226-3160	Bixcut Head	16.0
0226-3165	Bixcut Head	16.5
0226-3170	Bixcut Head	17.0
0226-3175	Bixcut Head	17.5
0226-3180	Bixcut Head	18.0
0226-4185	Bixcut Head	18.5
0226-4190	Bixcut Head	19.0
0226-4195	Bixcut Head	19.5
0226-4200	Bixcut Head	20.0
0226-4205	Bixcut Head	20.5
0226-4210	Bixcut Head	21.0
0226-4215	Bixcut Head	21.5
0226-4220	Bixcut Head	22.0
0226-4225	Bixcut Head	22.5
0226-4230	Bixcut Head	23.0
0226-4235	Bixcut Head	23.5
0226-4240	Bixcut Head	24.0
0226-4245	Bixcut Head	24.5
0226-4250	Bixcut Head	25.0
0226-4255	Bixcut Head	25.5
0226-4260	Bixcut Head	26.0
0226-4265	Bixcut Head	26.5
0226-4270	Bixcut Head	27.0
0226-4275	Bixcut Head	27.5
0226-4280	Bixcut Head	28.0

BIXCUT SHAFTS (STERILE)^{1,2,3, 4}

REF	Description	Length mm
0227-8240S	Mod. Trinkle	284
0227-3000S	Mod. Trinkle	448
0227-8510S	Mod. Trinkle	510
0227-8885S	Mod. Trinkle	885
0226-8240S	AO	284
0226-3000S	AO	448

SHAFT ACCESSORIES

REF	Description
3212-0-210	Grommet (pack of 25)
3212-0-220	Grommet inserter/extractor
0225-6010	Grommet Case

Note:

Bixcut Fixed Head – Modified Trinkle fitting available in same diameters and length as the AO Fitting (REF No: 0227-xxxx)

* Use with 2.2mm × 800mm Smooth Tip and 2.5mm × 800mm Ball Tip Guide Wires only.

** Use with Stryker power equipment.

- Non-Sterile shafts supplied without Grommet. Use new Grommet for each surgery. See shaft accessories.
- Sterile shafts supplied with grommet pre-assembled.
- For non-sterile leave “S” off the REF Number when ordering (510 and 885mm available only sterile Modified Trinkle Fitting).
- non-sterile, AO Fitting Shafts in 510 and 885mm are available as build to order items:
 - CM810921 AO Fitting Shaft, length 510mm
 - CM810923 AO Fitting Shaft, length 885mm.

BIXCUT FIXED HEAD – AO FITTING**

REF	Diameter mm	Length mm
0225-5060	6.0*	400
0225-5065	6.5*	400
0225-5070	7.0*	400
0225-6075	7.5	480
0225-6080	8.0	480
0225-6085	8.5	480
0225-6090	9.0	480
0225-6095	9.5	480
0225-6100	10.0	480
0225-6105	10.5	480
0225-6110	11.0	480
0225-8115	11.5	480
0225-8120	12.0	480
0225-8125	12.5	480
0225-8130	13.0	480
0225-8135	13.5	480
0225-8140	14.0	480
0225-8145	14.5	480
0225-8150	15.0	480
0225-8155	15.5	480
0225-8160	16.0	480
0225-8165	16.5	480
0225-8170	17.0	480
0225-8175	17.5	480
0225-8180	18.0	480

OPTIONAL INSTRUMENTS

REF	Description
0227-0060	Hand Reamer 6 mm w/Mod Trinkle connection
0227-0070	Hand Reamer 7 mm w/Mod Trinkle connection
0227-0080	Hand Reamer 8 mm w/Mod Trinkle connection
0227-0090	Hand Reamer 9 mm w/Mod Trinkle connection
1806-6520	Curved Reduction Rod 8.5 mm w/Mod Trinkle connection
1806-6500	T-Handle w/Mod Trinkle connection

BIXCUT TRAYS EMPTY

REF	Description
0225-6000	Tray, Modular Head (up to size 22.0mm)
0225-6001	Tray, Modular Head (up to size 28.0mm)
0225-8000	Tray, Fixed Head (up to size 18.0mm)
0225-6040	Mini Trauma Tray (for modular heads 9-18)
0225-6050	Mini Revision Tray (for modular heads 9-28)

Notes

Notes

Joint Replacements

Trauma, Extremities & Deformities

Cranio-maxillofacial

Spine

Biologics

Surgical Products

Neuro & ENT

Interventional Spine

Navigation

Endoscopy

Communications

Imaging

Patient Care & Handling Equipment

EMS Equipment**Manufactured by:**

Stryker Trauma GmbH
Prof.-Küntschers-Strasse 1-5
D-24232 Schönkirchen
Germany

www.osteosynthesis.stryker.com

This document is intended solely for the use of healthcare professionals. A surgeon must always rely on his or her own professional clinical judgment when deciding whether to use a particular product when treating a particular patient. Stryker does not dispense medical advice and recommends that surgeon's be trained in the use of any particular product before using it in surgery. The information presented in this brochure is intended to demonstrate a Stryker product. Always refer to the package insert, product label and/or user instructions including the instructions for Cleaning and Sterilization (if applicable) before using any Stryker products. Products may not be available in all markets. Product availability is subject to the regulatory or medical practices that govern individual markets. Please contact your Stryker representative if you have questions about the availability of Stryker products in your area.

Stryker Corporation or its divisions or other corporate affiliated entities own, use or have applied for the following trademarks or service marks: Bixcut, Gamma, Gamma3, Stryker, T2. All other trademarks are trademarks of their respective owners or holders.

The products listed above are CE marked.

Literature Number: **B1000085 Rev 1**
1/11

Copyright © 2011 Stryker

