

stryker

Pangea[®]

A force in plating



Where fit and simplicity **unite as one.**

Powered by the collaboration of diverse and experienced orthopaedic surgeons and the SOMA design algorithm¹, **Pangea** is comprehensive and versatile, providing variable-angle plating for a world of needs.

At Stryker, **we are committed to innovation.**

We recognize the challenges you face and the diverse patients you care for every day. That understanding, paired with our unwavering commitment to innovation, led us to ask:

What's next for you and your patients?

The answer is our **Pangea plating portfolio**. A new system that is designed to meet your needs for **anatomical fit¹ and simplicity**.

Powered by the collaboration of diverse and experienced orthopaedic surgeons, Pangea's anatomical fit¹ brings in a global perspective, providing variable-angle plates for a wide variety of demographics around the world.

20

Anatomic plates

13

Utility plates

1

Platform

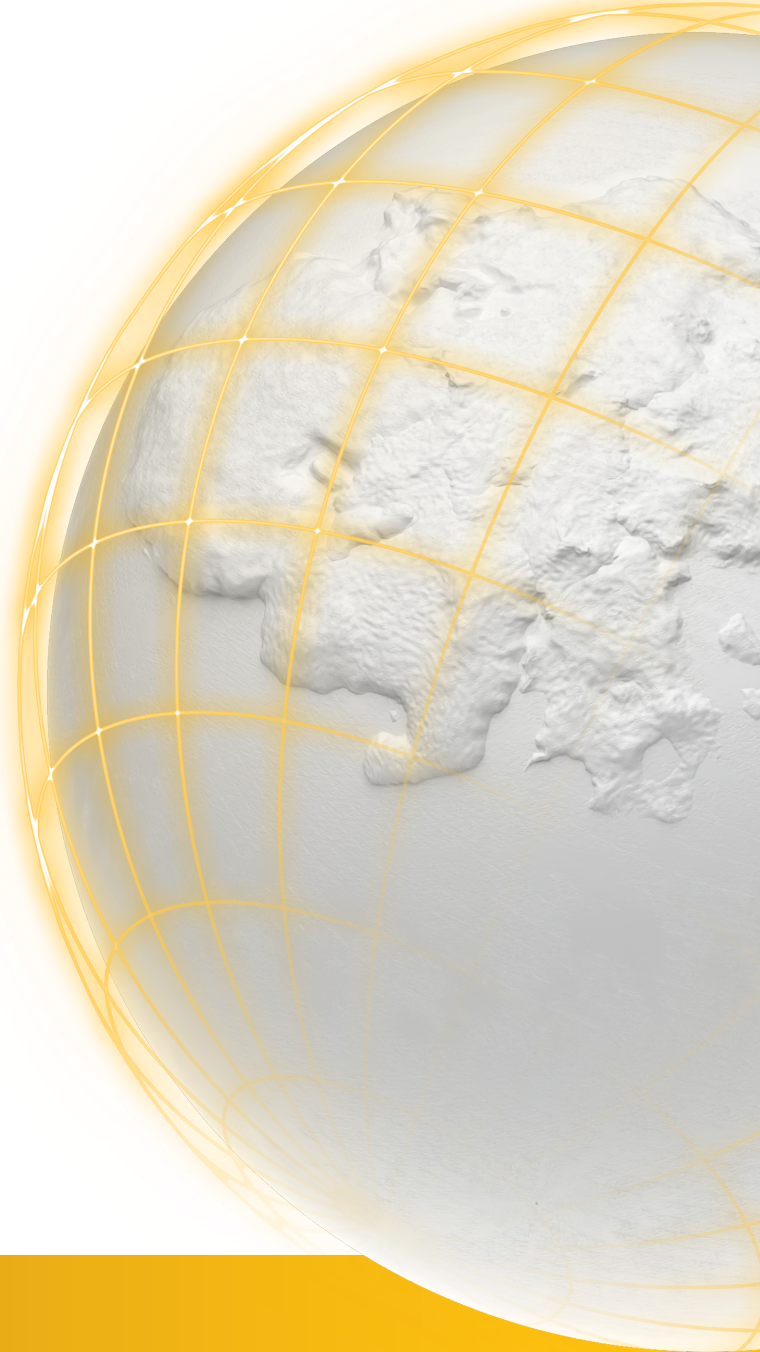

Fit

Stryker Orthopedic Modeling and Analytics (SOMA)	6
Features and benefits	11
Variable angle locking	28
Material considerations	31

Simplicity

One comprehensive system	35
Personalization and standardization	36
Color coded instrumentation	37

Pangea plating portfolio



20
Anatomic plates

13
Utility plates



A Humerus

Proximal Humerus
Proximal Humerus Posterior
Extra Articular Distal Humerus

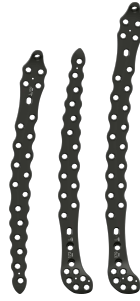

B PeriPRO femur

Proximal Femur
Distal Femur
Interprosthetic Femur



C Distal femur

Distal Lateral Femur
5.0 Distal Medial Femur
3.5 Distal Medial Femur

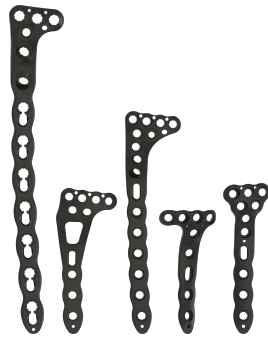

D Proximal tibia

Extra Articular Proximal Tibia
Partial Articular Proximal Tibia
Proximal Lateral Tibia
Proximal Posteromedial Tibia
Proximal Medial Tibia



E Distal tibia

Distal Anterolateral Tibia
Distal Medial Tibia
Distal Posterior Tibia



F Distal fibula

Distal Lateral Fibula
Distal Posterolateral Fibula
Distal Posterior Fibula



Large fragment

5.0 Narrow Straight Plate
5.0 Broad Straight Plate
5.0 Broad Curved Plate



Small fragment

3.5 Broad Straight Plate
3.5 Narrow Straight Plate
3.5 Hook Plate
3.5 T-plate
3.5 Narrow Curved Plate
3.5 1/3 Tubular Plate



Mini fragment

2.7 Narrow Straight Plate
2.7 Broad Straight Plate
2.7 Hook Plate
2.7 T-plate

Fit

Pangea empowers you to treat a diverse patient population with confidence. Shaped by the collaborative efforts of 26 world-renowned orthopaedic surgeons and directly informed by **Stryker Orthopaedic Modeling and Analytics (SOMA)**, Pangea is a portfolio of anatomically informed implants.¹



Stryker Orthopaedics Modeling and Analytics (SOMA)

Stryker Orthopaedic Modeling and Analytics (SOMA)

Features and benefits

Variable angle locking

Material considerations



Anatomically informed fit

Why is a well-fitting implant important?

Relying on plate bending for plate fit may cause early mechanical failure in trauma plating procedures.²

The Pangea systems were designed with this in mind. Using the Stryker Orthopaedics Modeling and Analytics (SOMA) database, Pangea offers an evidence-based, anatomically informed implant.

Together, the surgeon design panel and engineers designed a plating portfolio centered around anatomic fit and a comprehensive and simplified instrument platform.

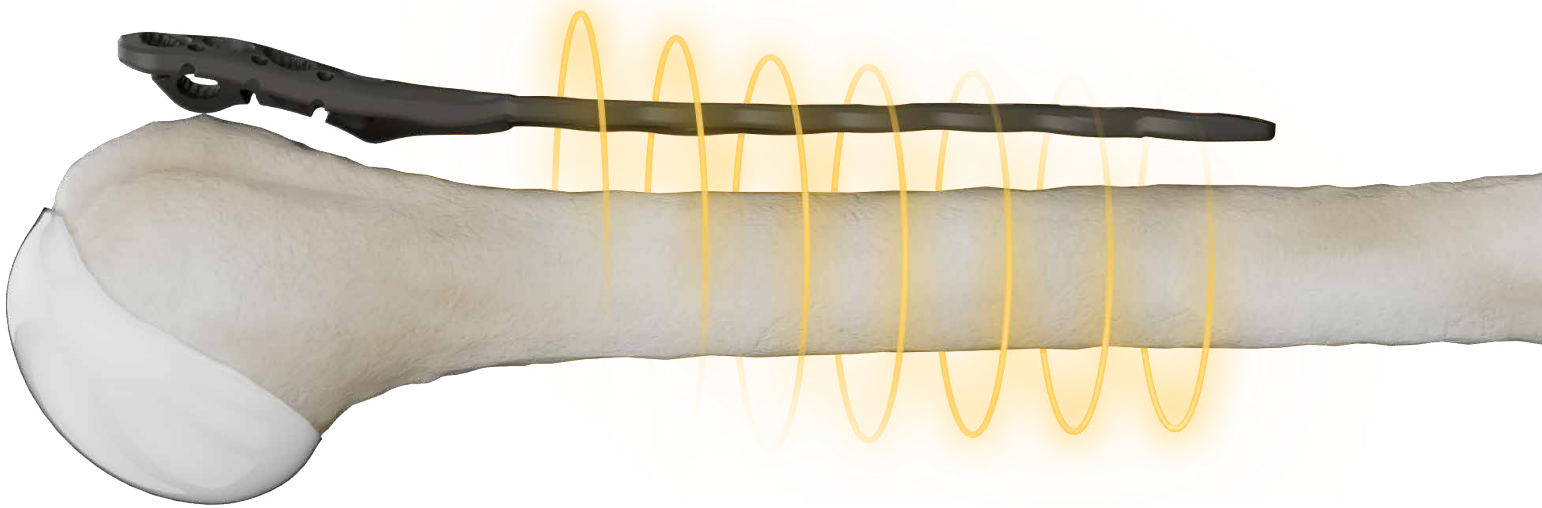

A well fitting plate

- May reduce the need for intraoperative plate bending^{3,4,5,6} which may allow for improved procedural efficiency^{5,6}
- May result in reducing of soft tissue impingement and might decrease the risk of skin irritations^{7,8,9}
- May help with fracture alignment^{5,8,10}



Powered by SOMA

Gamma4, T2 Alpha and VariAx 2 Wrist were powered by SOMA, and now so is Pangea.

Pangea offers an evidence-based design for anatomically informed implant. Using **Stryker Orthopaedic Modeling and Analytics (SOMA)** and partnering with the expertise of 26 world-renowned orthopedic surgeons, Pangea was designed to focus on plate fit, screw placement, and to elevate the plating market through contoured implants in multiple diverse sub-populations.¹¹



What is SOMA?¹²

Stryker collects CT scans from hospitals and institutions from all over the world. These CT scans are segmented in a standardized manner as 3D bone models and stored in a database together with demographical data.¹²

Dedicated applications using state of the art algorithms are employed to mine the database for information (shape variability, bone density, implant fit). Together, the database and the tools make up the digital SOMA platform.¹²

The current version of the SOMA database (SOMA database, version 2021.0.7, Schönkirchen, Germany) contains more than 40,000 bones from more than 6,600 patients.¹³

Objective design & enhanced anatomical compliance

State of the art digital technology

Covers a broad anatomic range

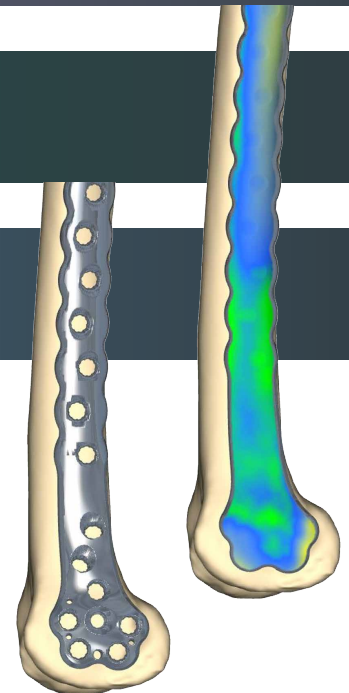

SOMA foundation: Bone database¹³

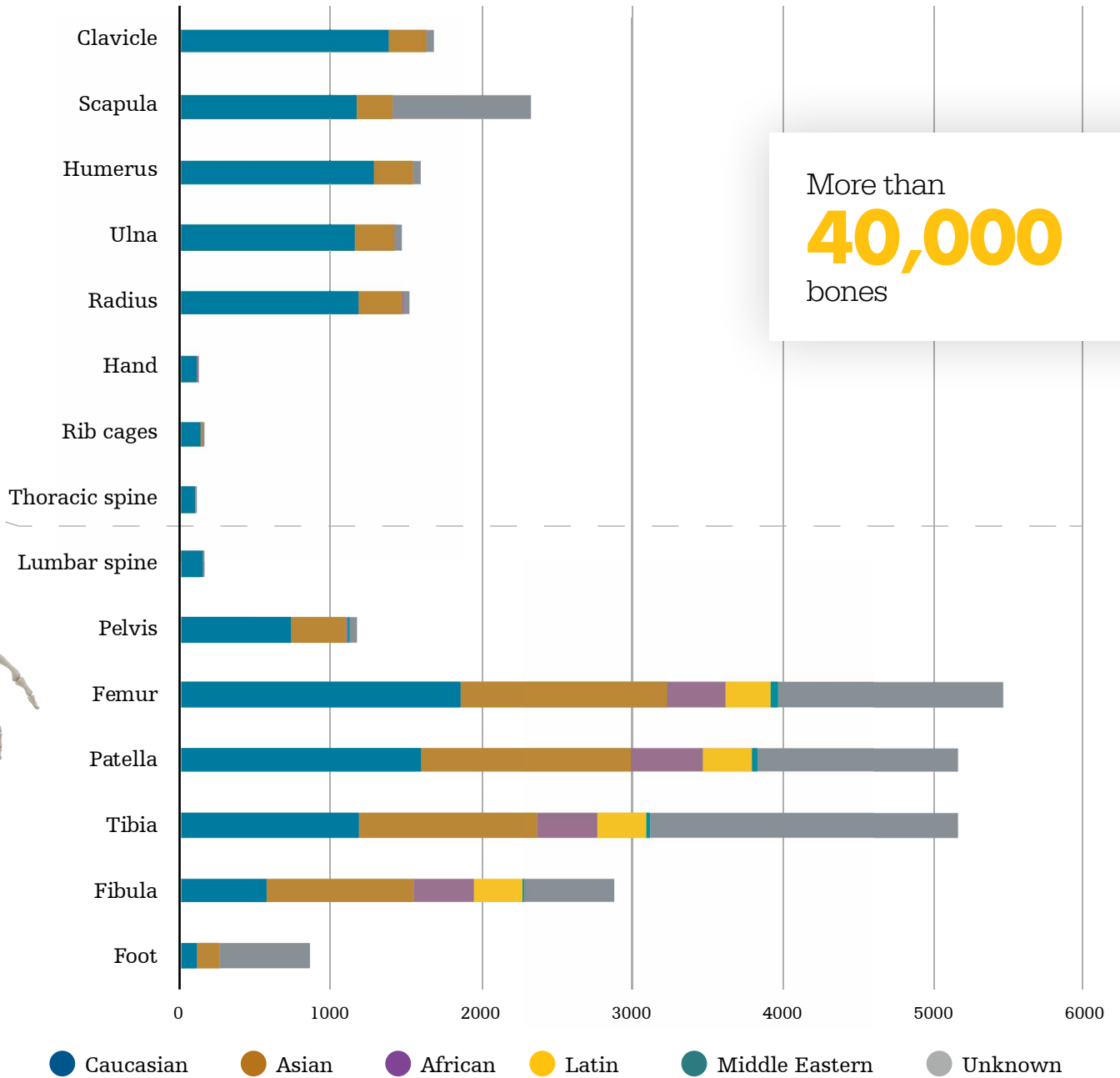

Capabilities^{11,12}

Anatomical measurements

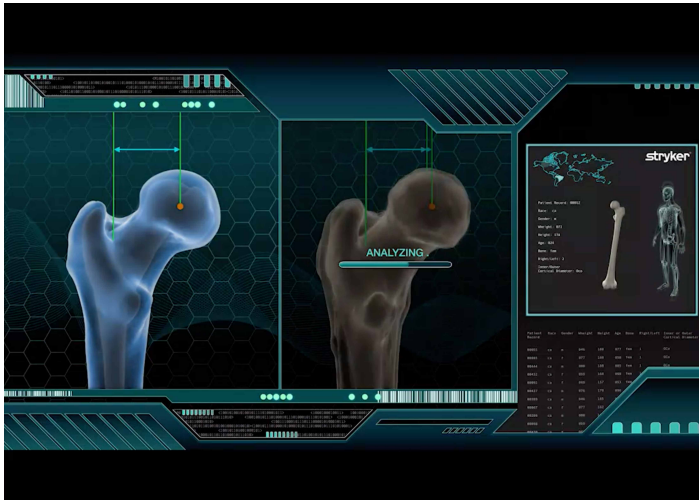

Implant fitting

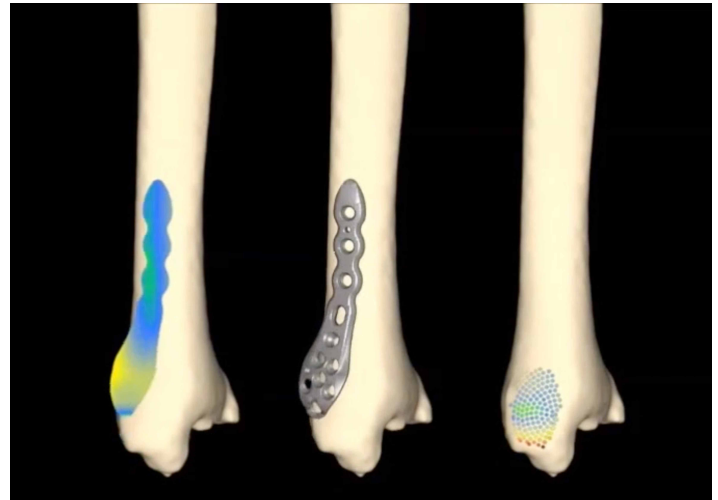

Density assessment

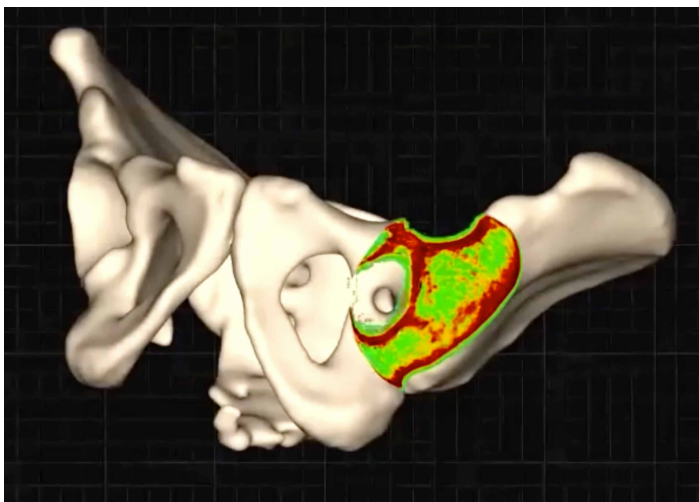

Fracture heatmaps

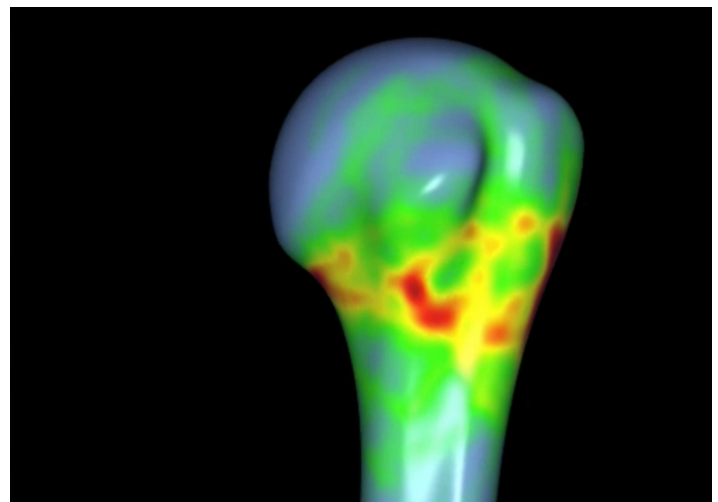

Mapping the SOMA landscape¹¹

Bone database

The SOMA bone database contains a collection of 6,600 and growing clinical CT scans and contains over 40,000 3D bone models.¹³

Software applications and capabilities

In order to mine the bone database with high efficiency, a dedicated set of software tools is used. With ever-evolving Stryker products being developed, the database and the capabilities of the SOMA tools are continuously expanded.

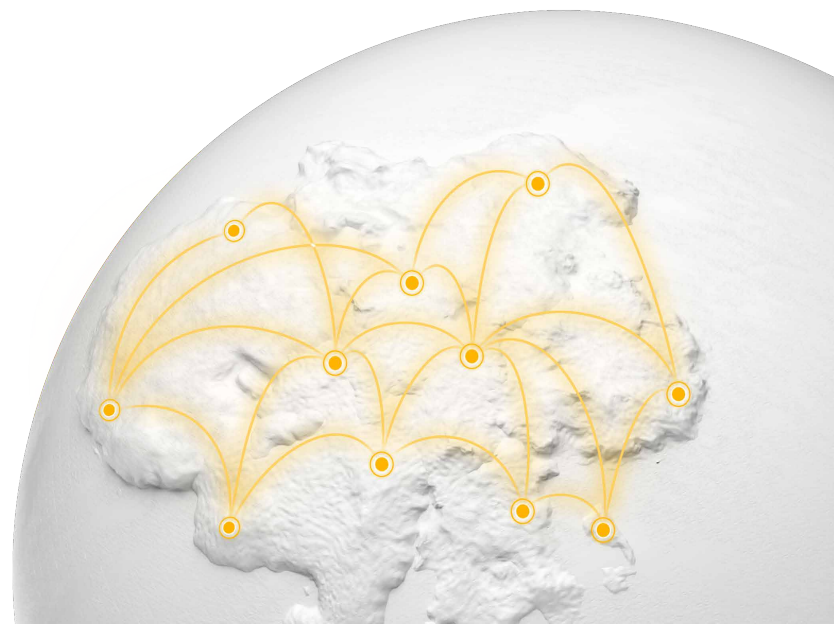

Features and benefits

Stryker Orthopedic Modeling and Analytics (SOMA)

Features and benefits

Variable angle locking

Material considerations



Anatomic plates



A Humerus

- Proximal Humerus
- Proximal Humerus Posterior
- Extra Articular Distal Humerus

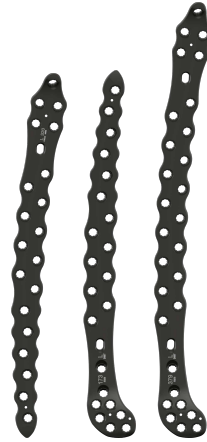

B PeriPRO femur

- Proximal Femur
- Distal Femur
- Interprosthetic Femur



C Distal femur

- Distal Lateral Femur
- 5.0 Distal Medial Femur
- 3.5 Distal Medial Femur

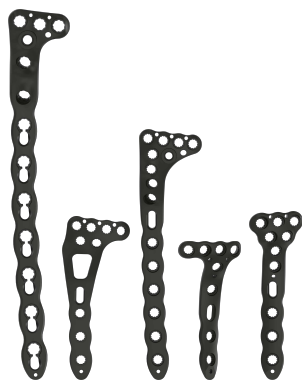

D Proximal tibia

- Extra Articular Proximal Tibia
- Partial Articular Proximal Tibia
- Proximal Lateral Tibia
- Proximal Posteromedial Tibia
- Proximal Medial Tibia



E Distal tibia

- Distal Anterolateral Tibia
- Distal Medial Tibia
- Distal Posterior Tibia



F Distal fibula

- Distal Lateral Fibula
- Distal Posterolateral Fibula
- Distal Posterior Fibula

Humerus plates



Proximal screw row incorporates cross-diverging screw trajectories

Monoaxial hole

Straight anterior plate contour
Supports reduction along the bicipital groove

Waisted scalloped shape

7 beveled and angled 2.0mm suture hole cutouts
Provide flexibility in tendon and tuberosity fixation and to facilitate easier passage of suture after the plate is placed on bone

Variable-angle screw holes
Circular holes that accommodate screws are universal, accepting non-locking screws and locking screws within a 30° cone

9mm K-wire slot
Assists with proximal / distal plate positioning

3 variable angle calcar screw holes
Provide flexibility for screw placement in calcar bone of varying fracture patterns

2.0mm proximal K-wire hole
To provide temporary fixation

2.0mm K-wire hole
Designed to aim at center of capitulum to help with placement

Graduated proximal plate thickness
Allows for robust humeral shaft fixation while maintaining a low-profile design distally

Rounded and tapered end
Designed to allow for smooth insertion under the soft tissue

Hybrid LC Holes
Allows up to 2mm of compression per hole or can be used for a variable angle locking screw
A: Universal: For locking or non-locking screws
B: Compression: For non-locking screws only

Proximal Humerus

- Designed with proximal, cross diverging screw trajectories and 3 calcar screw holes

Proximal Humerus Posterior

- Extensions are designed to increase fixation by providing an option for perpendicular screw placement in the setting of comminuted tuberosity fractures

Extra Articular Distal Humerus

- Designed for spiral, distal third shaft fractures with closer anatomic fit to LCP Extra Articular Distal Humerus¹
- Hybrid compression and locking holes for up to 2mm of compression if needed

Humerus plates: fit matters

Anatomic fit assessment ¹

To assess the anatomical compliance of the Pangea Humerus plates, the plates were fitted with the Stryker Implant Fitting Tool (SIFT) onto 741 adult bone models available within the SOMA database.¹

The MBP distance was calculated for each plate type. The MBP distance is the mean distance between plate and bone. This metric was used to compare the fit of the Pangea plates to the fit of benchmark devices. A lower median MBP distance equates to a better fit because it means the plate fits closer to the bone.

Proximal Humerus

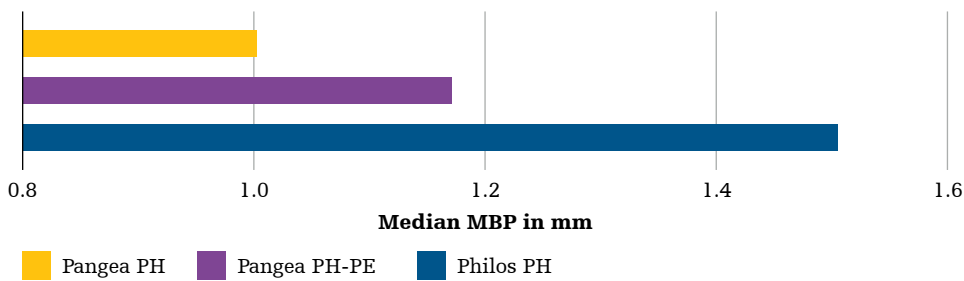

Comparison of Proximal Humerus plates*



Distal Humerus

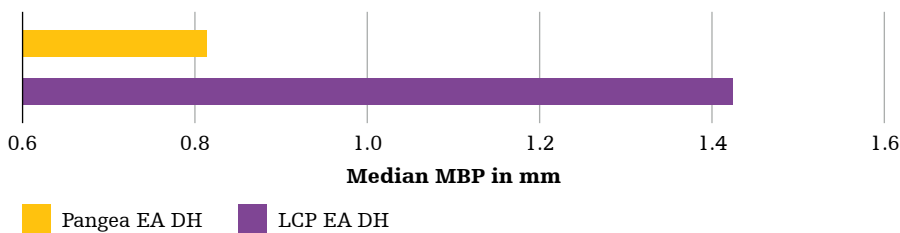

Comparison of Distal Humerus plates*



*The comparative assessments shown are derived from computer-based anatomical modeling using SOMA data and internal analysis. These findings may not be indicative of clinical performance.

PeriPRO femur plates

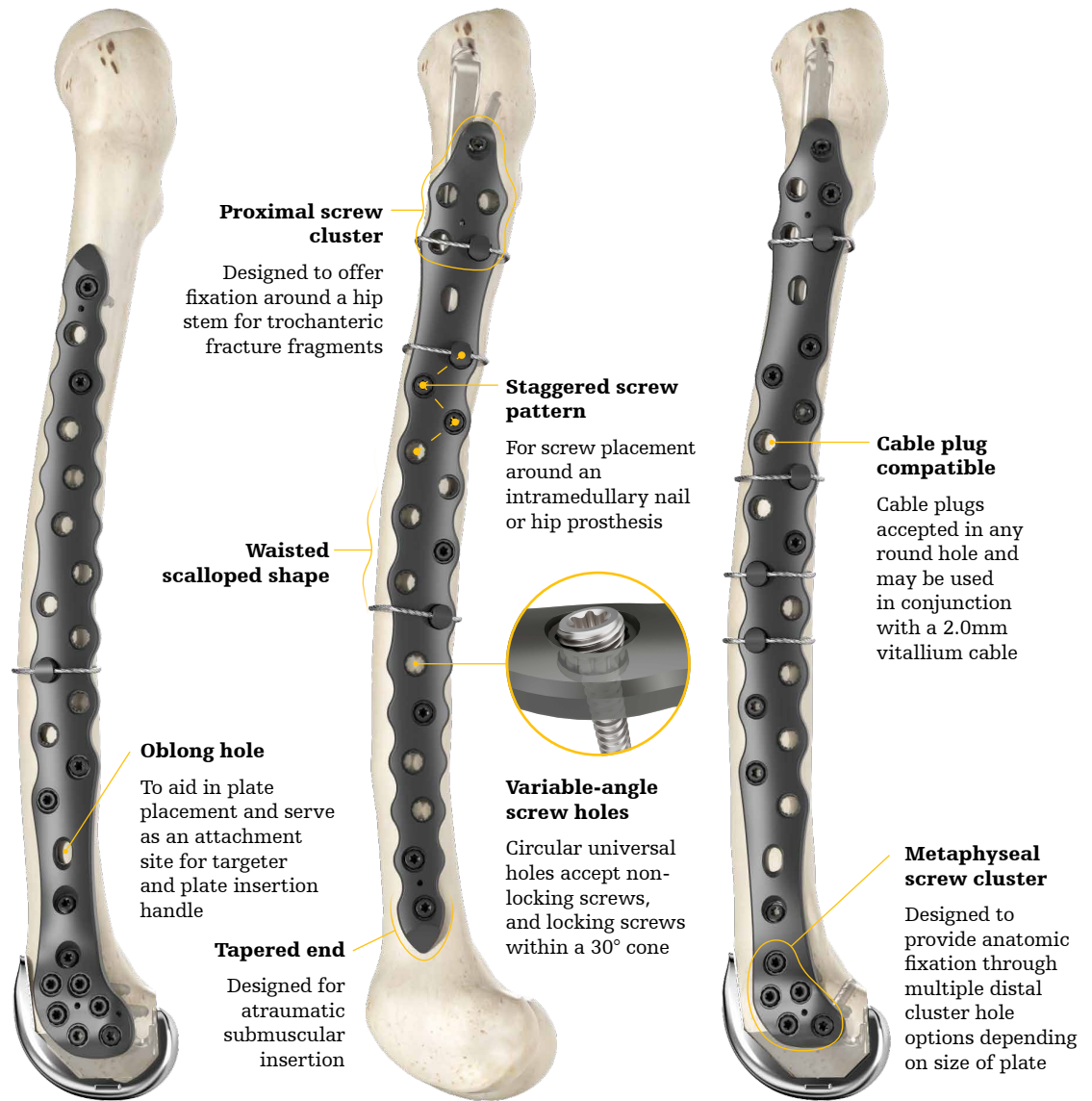
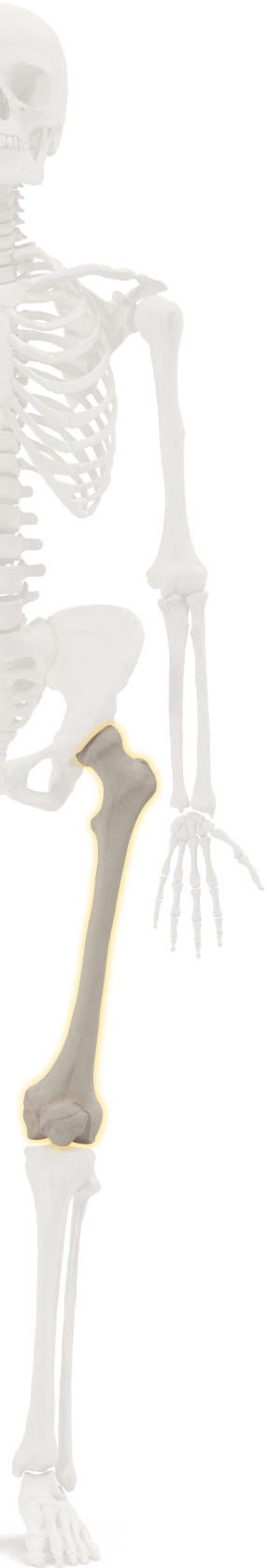

Distal Femur

- Tapered end designed for atraumatic submuscular insertion
- Metaphyseal screw cluster provides anatomic fixation through size adapted options

Proximal Femur

- Proximal screw cluster designed to offer fixation around a hip stem for trochanteric fracture fragments
- Tapered end designed for atraumatic submuscular insertion

Interprosthetic Femur

- Dedicated interprosthetic plate designed to span from the femoral condyle to the greater trochanter to maximize plate working length
- Changes in radius of curvature, width of the proximal cluster, and amount of holes in the distal cluster are all determined by SOMA¹⁴

PeriPRO radius of curvature¹⁴

PeriPRO Distal Femur Plates

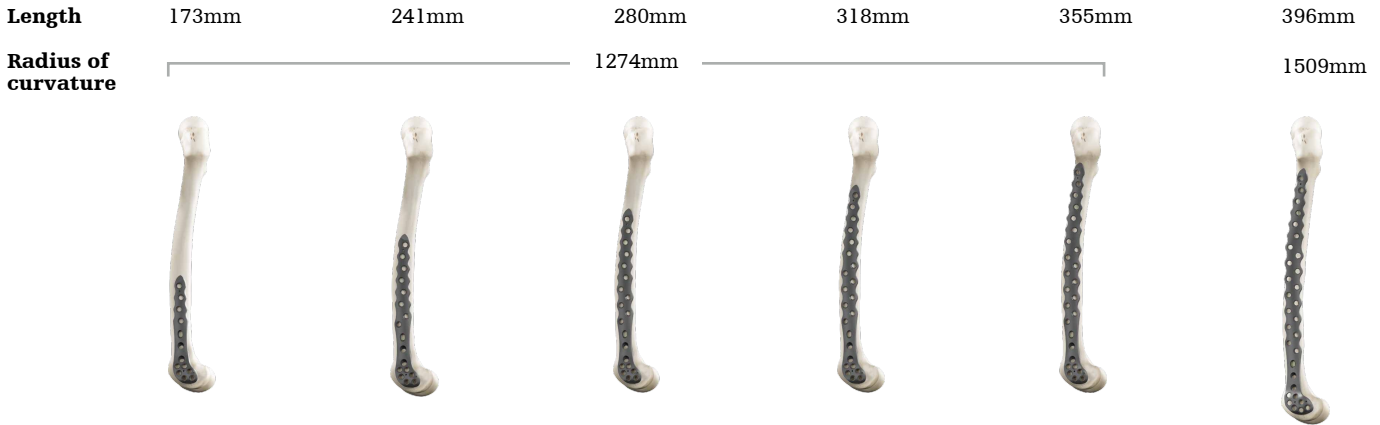

PeriPRO Proximal Femur Plates

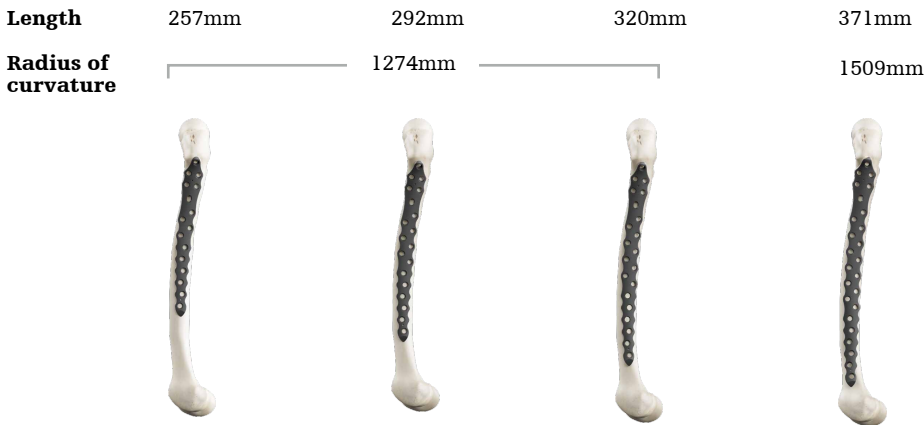

PeriPRO Interprosthetic Femur Plates

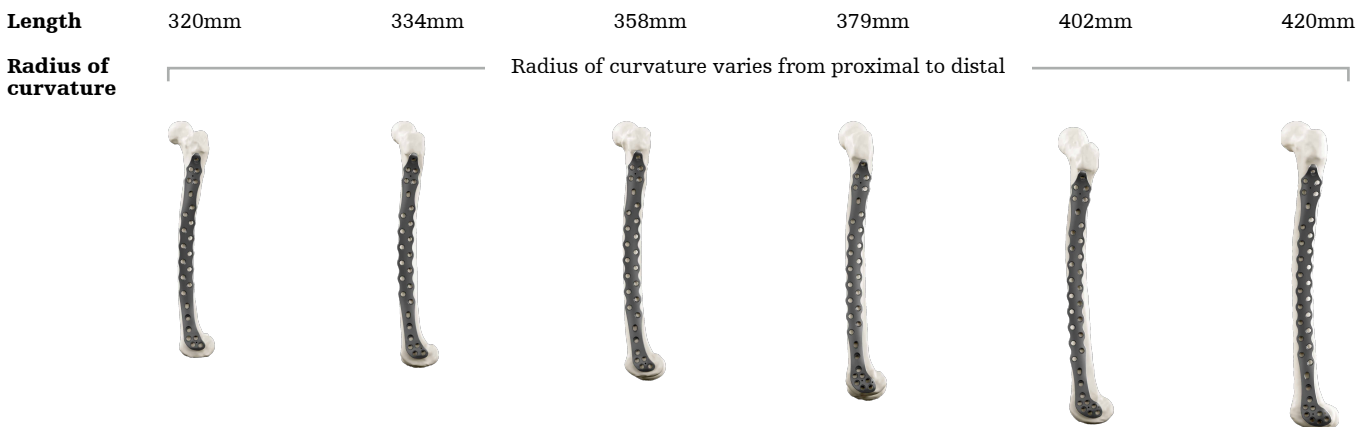

Distal femur plates

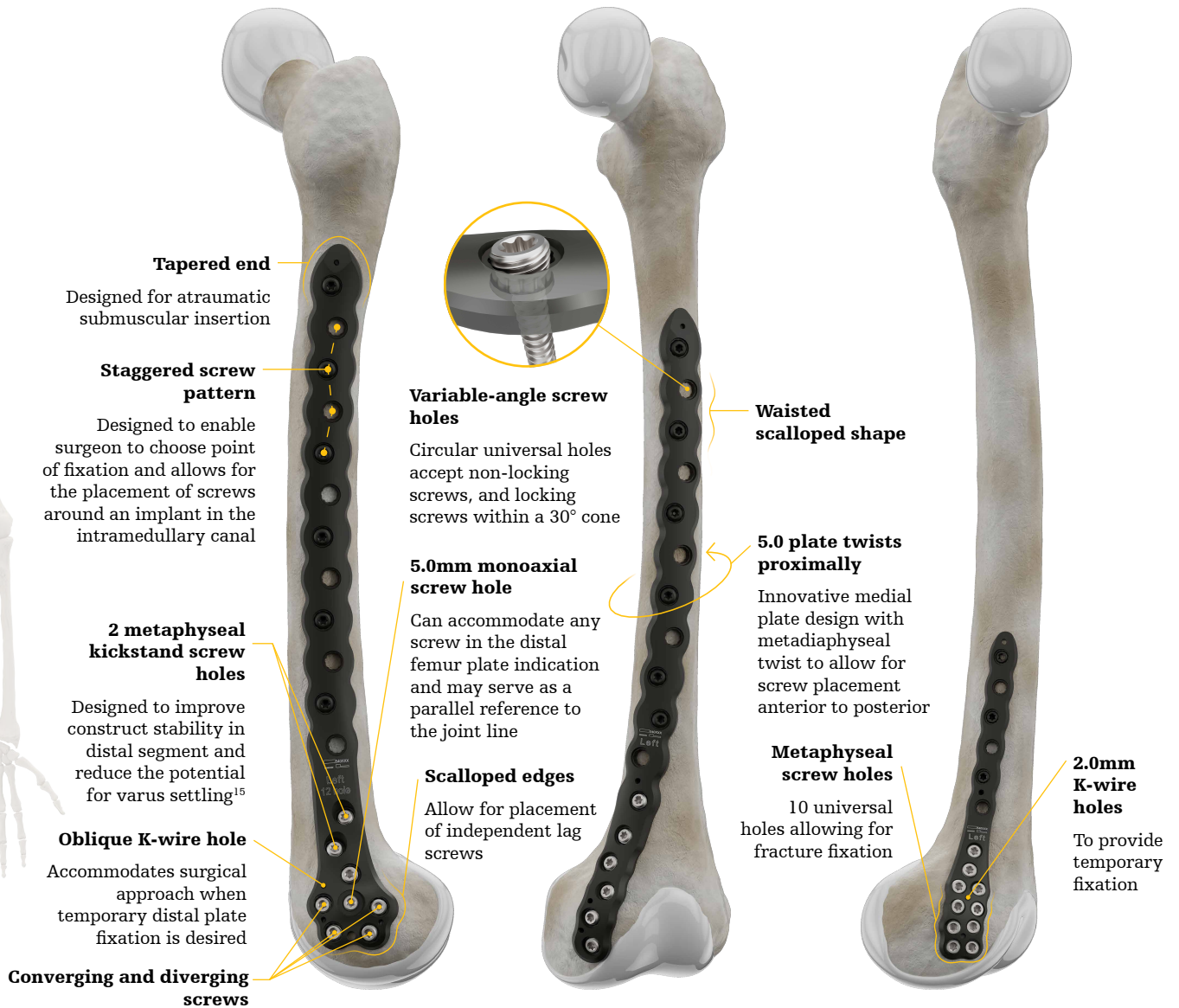
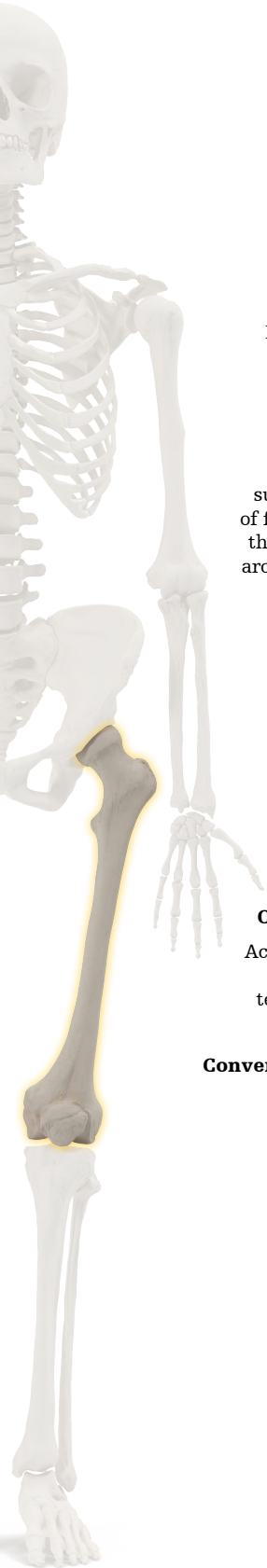

Distal Lateral Femur

- Sits anteriorly to aid in freedom for potentially more fixation
- Nominal screw trajectories designed to avoid the intercondylar notch and reduce the use of unicondylar screws

5.0mm Distal Medial Femur

- Innovative medial plate which proximally twists to lie on the anterior femur providing a more controlled access to shaft screw insertion
- May be used as medial based fixation for meta-diaphyseal fractures or as a supplement to lateral plate fixation when dual plate fixation is desired

3.5mm Distal Medial Femur

- May be used for isolated medial condylar fractures or as a supplement to lateral plate fixation
- Designed to be used for buttressing, as well as when dual plate fixation is desired
- Distal footprint designed to reduce the potential for disruption of MCL origin

Distal femur plates: fit matters

Anatomic fit assesment ¹

To assess the anatomical compliance of the Pangea Distal femur plates, the plates were fitted with the Stryker Implant Fitting Tool (SIFT) onto 1379 adult bone models available within the SOMA database.¹

The MBP distance was calculated for each plate type. The MBP distance is the mean distance between plate and bone. This metric was used to compare the fit of the Pangea plates to the fit of benchmark devices. A lower median MBP distance equates to a better fit because it means the plate fits closer to the bone.

Distal Lateral Femur

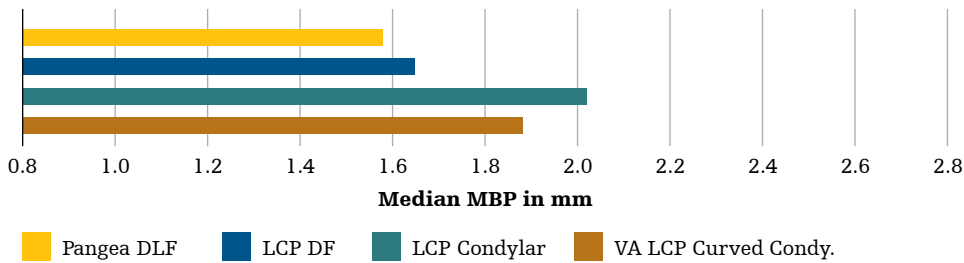

Comparison of Distal Lateral Femur plates*

5.0mm Distal Medial Femur

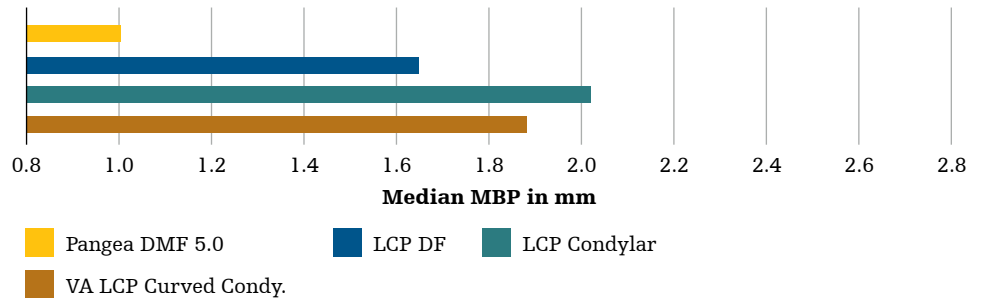

Comparison of Distal Medial Femur 5.0mm plates*

3.5mm Distal Medial Femur

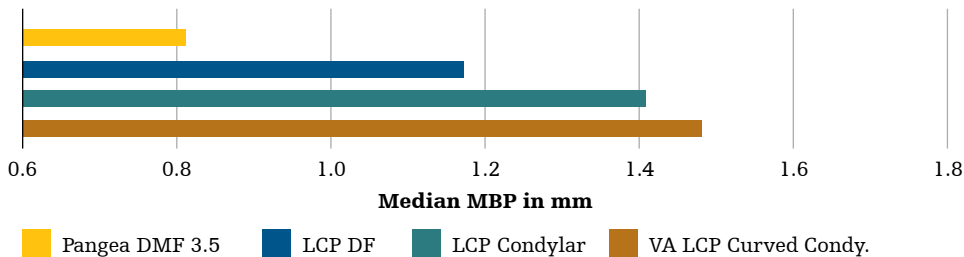

Comparison of Distal Lateral Femur and Distal Medial Femur 3.5mm plates*

*The comparative assessments shown are derived from computer-based anatomical modeling using SOMA data and internal analysis. These findings may not be indicative of clinical performance.

Proximal tibia plates



2.0mm Proximal Suture holes with undercuts

Allows for suture threading after plate placement and K-wire placement

Kickstand screw

Designed to provide support for the medial tibia plateau and joint

Waisted scalloped shape

2.0mm K-wire hole

To provide temporary fixation

Window

Designed to allow tamp placement for articular surface elevation and bone graft insertion after provisional plate application

2.2mm plate thickness

Designed with an improved anatomic fit and low profile design to reduce the profile under the soft tissue

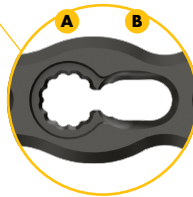

Hybrid LC Holes

Allows up to 2mm of compression per hole or can be used for a variable angle locking screw

A: Universal: For locking or non-locking screws

B: Compression: For non-locking screws only

Proximal row of rafting screws

Designed to follow the angle of the tibial plateau to support the articular surface

Locking or non-locking screws can be used to raft articular depression

Oblong hole

To aid in plate placement

Monoaxial hole

2 Kickstand screws

Designed to provide support for the medial tibia plateau



Variable-angle screw holes

Circular universal holes accept non-locking screws and locking screws within a 30° cone

Proximal Extra Articular Tibia

- Robust plate, which is thicker than the other Pangea Proximal Tibia Plates and utilizes the large fragment screw platform for plating of proximal tibia fractures involving the metaphysis and meta diaphysis
- Utilized when increased construct rigidity is required
- Hybrid compression and locking holes for up to 2mm of compression if needed

Proximal Partial Articular Tibia

- Low profile, malleable plate designed for lateral plateau fracture variants
- Designed as a buttress plate to aide with split or split/depressed lateral plateau cases
- A central window allows packing of graft after application of the plate

Proximal Lateral Tibia

- Designed to aide with lateral split, depression, or split-depression, and bicondylar tibial plateaus
- Utilized with variable angle locking technology, the plate may be utilized for single implant treatment of select bicondylar tibial plateau fractures

Proximal tibia plates: fit matters

Anatomic fit assesment ¹

To assess the anatomical compliance of the Pangea Proximal tibia plates, the plates were fitted with the Stryker Implant Fitting Tool (SIFT) onto 938 adult bone models available within the SOMA database.¹

The MBP distance was calculated for each plate type. The MBP distance is the mean distance between plate and bone. This metric was used to compare the fit of the Pangea plates to the fit of benchmark devices. A lower median MBP distance equates to a better fit because it means the plate fits closer to the bone.

Proximal Extra Articular Tibia

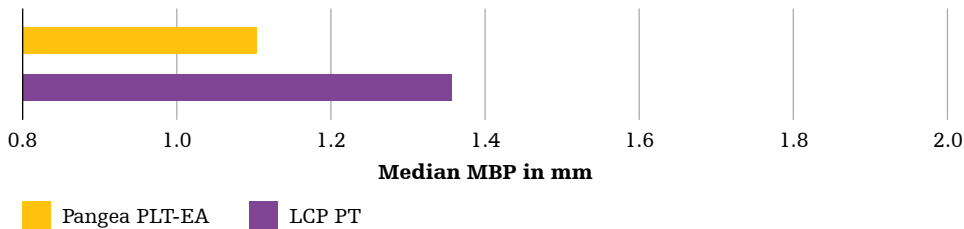

Comparison of proximal lateral extra articular tibia plates*

Proximal Lateral Tibia

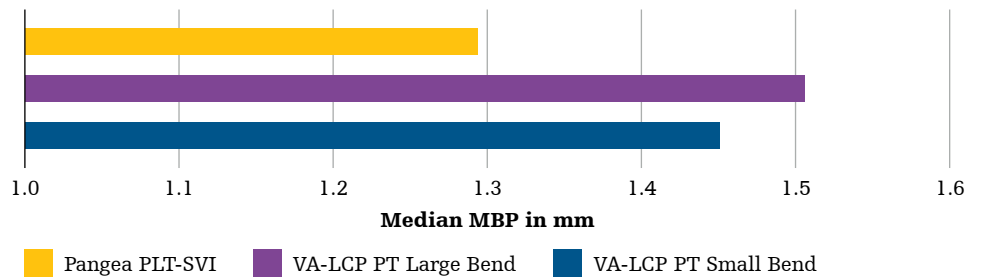

Comparison of proximal lateral tibia plates*

*The comparative assessments shown are derived from computer-based anatomical modeling using SOMA data and internal analysis. These findings may not be indicative of clinical performance.

Proximal medial tibia plates



Triangular head shape

Proximal surface allows for buttress surface and screws for proximal screw fixation

2.0mm K-wire hole

To provide temporary fixation

Posterior extension hole

Allows buttress effect with lateral support of bone fragment with plate extension

Variable-angle screw holes

Circular universal holes accept non-locking screws and locking screws within a 30° cone

Posteromedial extension

Asymmetric plate shape designed to support posterior buttressing by extending the plate more laterally

Proximal rafting screws

Designed with variable angle locking technology which allows placement in conjunction with lateral based implants

Oblong hole

To aid in plate placement

Proximal Medial Tibia

- Direct medial placement
- Designed for a proximal tibial fracture where fixation is needed on the medial side, for a fracture that spans into the diaphysis

Proximal Posteromedial Tibia

- Designed to help with posteromedial fracture fragments often associated with bicondylar tibial plateau fractures
- Proximal plate design facilitating lateral capture of the posteromedial fragment
- Offers alternative to traditional medial tibia plate

Proximal tibia plates: fit matters

Anatomic fit assesment ¹

To assess the anatomical compliance of the Pangea proximal tibia plates, the plates were fitted with the Stryker Implant Fitting Tool (SIFT) onto 938 adult bone models available within the SOMA database.¹

The MBP distance was calculated for each plate type. The MBP distance is the mean distance between plate and bone. This metric was used to compare the fit of the Pangea plates to the fit of benchmark devices. A lower median MBP distance equates to a better fit because it means the plate fits closer to the bone.

Proximal Medial Tibia

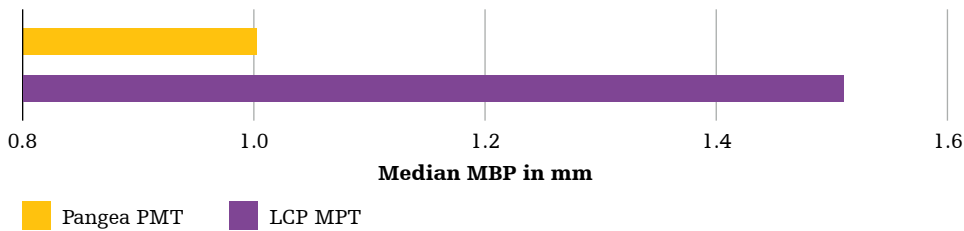

Comparison of Proximal Medial Tibia plates*



Proximal Posteromedial Tibia

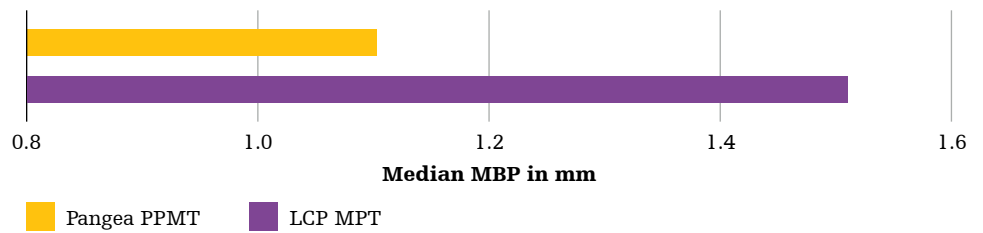

Comparison of Proximal Posteromedial Tibia plates*

*The comparative assessments shown are derived from computer-based anatomical modeling using SOMA data and internal analysis. These findings may not be indicative of clinical performance.

Distal tibia plates

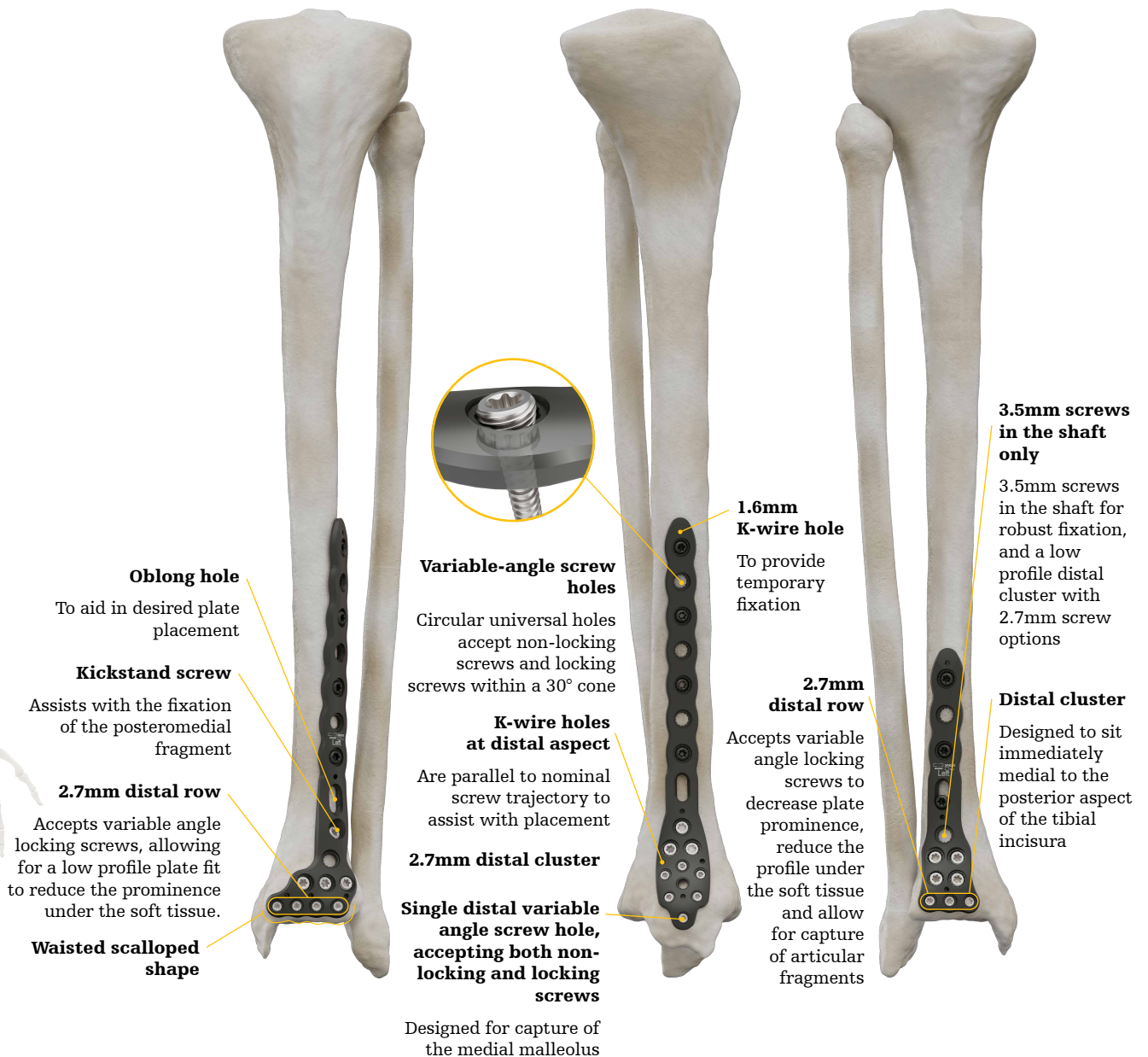

Distal Anterolateral Tibia

- Shaft anatomically curved proximal to the joint line for support distally

Distal Medial Tibia

- Designed to act as a buttress for the medial malleolus or medial fixation of pilon fractures
- Contour allows placement immediately proximal to the joint line for support while reducing the prominence under the soft tissue.

Distal Posterior Tibia

- Plate rotation allows centered placement of the distal screw cluster

Distal tibia plates: fit matters

Anatomic fit assesment ¹

To assess the anatomical compliance of the Pangea Distal tibia plates, the plates were fitted with the Stryker Implant Fitting Tool (SIFT) onto 938 adult bone models available within the SOMA database.¹

The MBP distance was calculated for each plate type. The MBP distance is the mean distance between plate and bone. This metric was used to compare the fit of the Pangea plates to the fit of benchmark devices. A lower median MBP distance equates to a better fit because it means the plate fits closer to the bone.

Distal Anterolateral Tibia

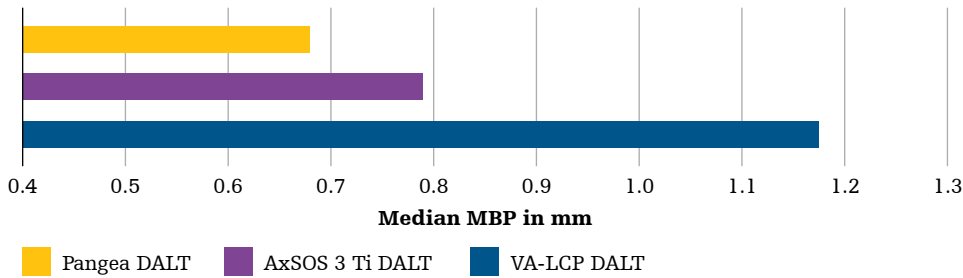

Comparison of Distal Posterior Tibia plates*



Distal Medial Tibia

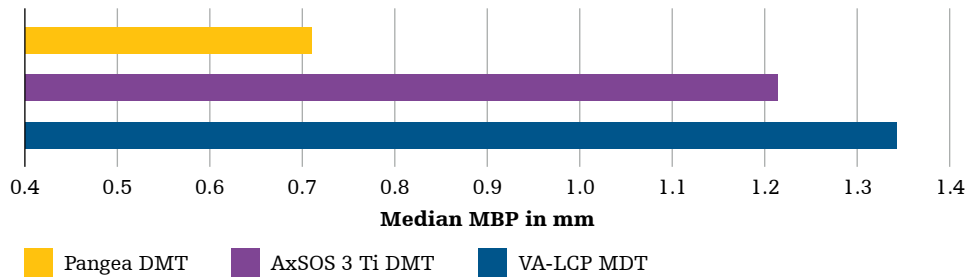

Comparison of Distal Medial Tibia plates*



Distal Posterior Tibia

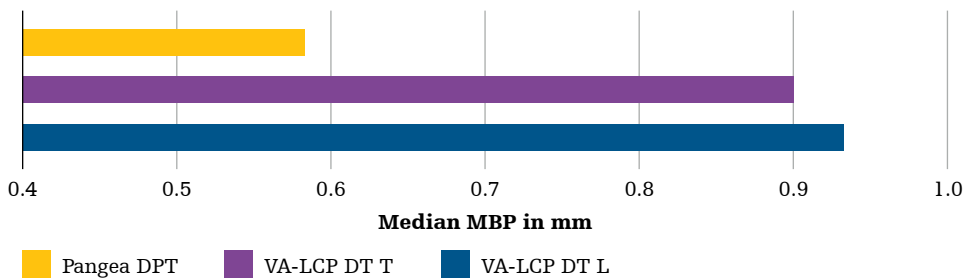

Comparison of Distal Posterior Tibia plates*



*The comparative assessments shown are derived from computer-based anatomical modeling using SOMA data and internal analysis. These findings may not be indicative of clinical performance.

Distal fibula plates



2 distal K-wire holes
Designed for distal placement

Distal Lateral Fibula

- 3.5mm screws in the shaft for robust fixation, and low profile distal cluster with 2.7mm screw options
- Designed to allow for centered placement of the distal cluster over the lateral malleolus with shaft placement on the posterolateral face of the shaft

Distal Posterolateral Fibula

- 3.5mm screws in the shaft for robust fixation, and low profile distal cluster with 2.7mm screw options
- Plate rotation designed to allow for placement along the posterolateral shaft of the fibula while facilitating the buttressing of oblique or external rotations in ankle fractures

Distal Posterior Fibula

- Utilizes only 2.7mm screws, allowing plates to be thin enough to be malleable
- Designed for placement through the posterolateral approach

Distal fibula plates: fit matters

Anatomic fit assesment ¹

To assess the anatomical compliance of the Pangea Distal fibula plates, the plates were fitted with the Stryker Implant Fitting Tool (SIFT) onto 544 adult bone models available within the SOMA database.¹

The MBP distance was calculated for each plate type. The MBP distance is the mean distance between plate and bone. This metric was used to compare the fit of the Pangea plates to the fit of benchmark devices. A lower median MBP distance equates to a better fit because it means the plate fits closer to the bone.

Distal Lateral Fibula

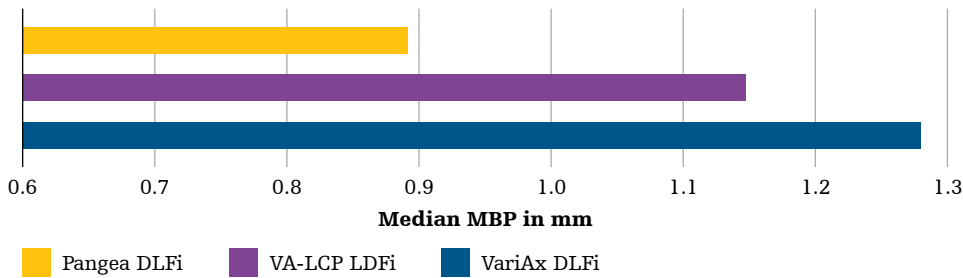

Comparison of Distal Lateral Fibula plates*

Distal Posterolateral Fibula

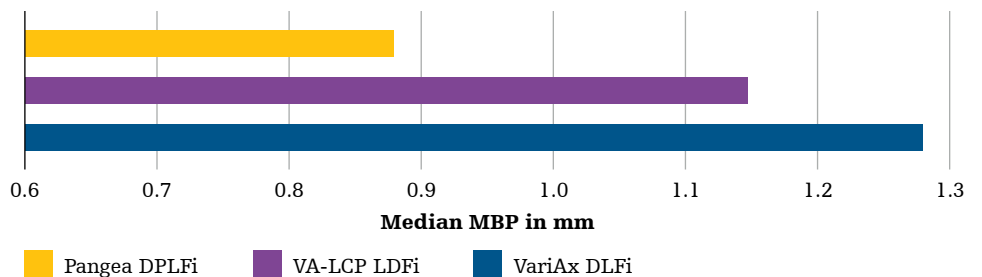

Comparison of Distal Posterolateral Fibula plates*

Distal Posterior Fibula

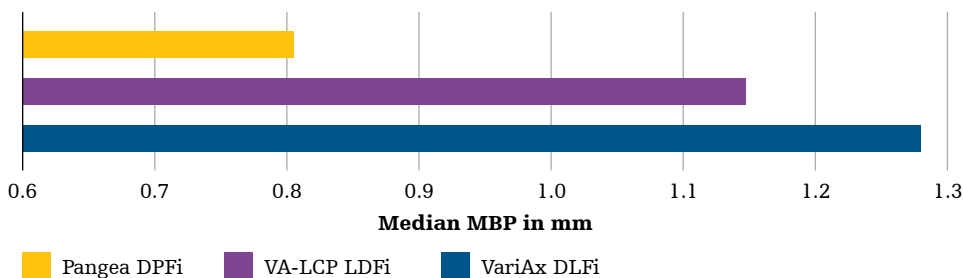

Comparison of Distal Posterior Fibula plates*

*The comparative assessments shown are derived from computer-based anatomical modeling using SOMA data and internal analysis. These findings may not be indicative of clinical performance.

Utility plates

Variable-angle screw holes
Circular holes that accommodate screws are universal, accepting locking and non-locking screws within a 30° cone

Hybrid LC holes
Allows up to 2mm of compression per hole or can be used for a variable angle locking screw
A: Universal: For locking or non-locking screws
B: Compression: For non-locking screws only

“Home run screw”
A non-locking screw hole between the tines to allow for fracture compression with a lag screw

Dual tines
Hook plates are equipped with 2 tines to aid in bone purchase

Screw compatibility: Ø 2.7mm Ø 3.5/4.0mm Ø 4.0/4.5/6.0mm Ø 5.0mm

Highlights

- Universal holes accept locking and non-locking screws within a 30° cone
- Hybrid L/C holes allow for up to 2mm of compression per hole or can be used for a variable angle locking screw
- Hook plates have 2 tines to aid in bone purchase and a non-locking screw hole between the tines to allow for fracture compression with a lag screw i.e., “home run screw”

Variable angle locking

Stryker Orthopedic Modeling and Analytics (SOMA)

Features and benefits

Variable angle locking

Material considerations



Strength from all angles

With Pangea, confidence comes from within.

Variable angle locking technology

Pangea’s variable angle locking technology uses a cobalt chrome (CoCr) locking screw, which is harder than the Ti6Al4V plate, allowing for the screwhead’s threads to form a definitive plate-screw interface in the plate’s locking hole by engaging the softer Ti6Al4V material.¹⁶

Based on the mechanical properties of two different types of metals, the cobalt chrome locking screws will not cold weld into titanium plates. This technology allows the user to aim and lock the screw into the plate within a true 30° cone revolving the predetermined hole trajectory.

The variable angle drill guide provided with the system offers guidance with respect to the limit of this 30° cone. The locking mechanism remains functional for up to two locking screw reinsertions.

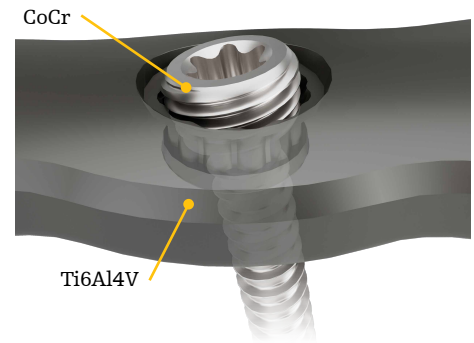

CoCr locking screw and Ti6Al4V plate hole

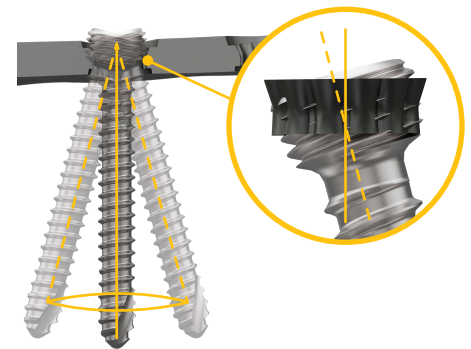

Universal holes offer 30° cone of angulation

Hybrid LC holes (locking/compression)

Hybrid LC holes allow for either active compression with the use of a non-locking screw in the compression section of the hole or variable angle locking with the use of a locking screw in the universal section of the hole. If locking is not desired, the universal section of the hole also accepts non-locking screws. Each Hybrid LC hole is designed to provide up to 2mm of compression.

Note: Hybrid LC holes are not available with every plate type.

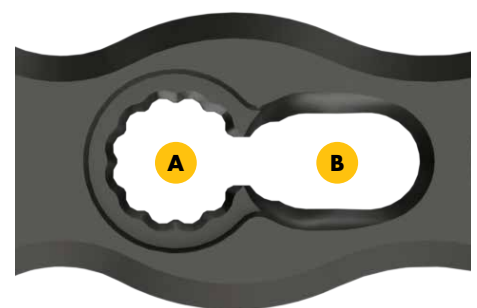

A: Universal: For locking or non-locking screws
B: Compression: For non-locking screws only

Hybrid LC hole

Strength from all angles

With Pangea, confidence comes from within.

Variable angle drill guide

The ball and cone variable angle drill guides are used in combination with respective drills to determine screw trajectory, if variable angle locking is what is needed.

The guide restricts the degree of screw angulation to 15° in any direction resulting in a true 30° cone. To ensure a precise 15° angulation, engage the cone end of the variable angle drill guide into the plate hole.

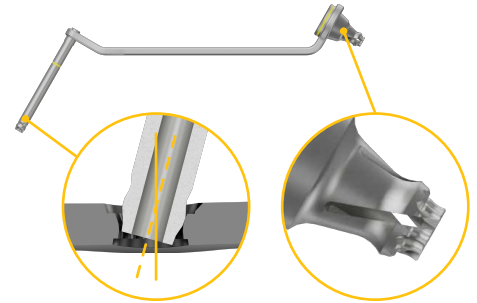

Variable angle drill guide

Fixed angle drill sleeve

If a monoaxial screw trajectory is needed, the appropriate drill sleeve insert is loosely inserted into the fixed angle sleeve.

- The assembly is inserted into the desired plate hole, which can be confirmed for proper placement with tactile feedback upon insertion
- The drill sleeve is threaded and inserted through the fixed angle sleeve and the knob is twisted, which fastens the assembly securely to the plate

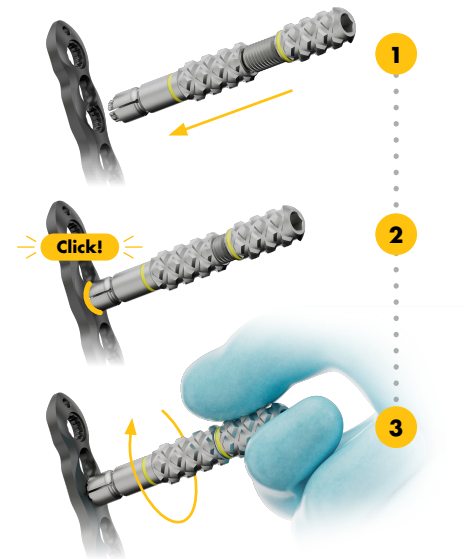

Fixed angle drill sleeve and insert assembly

Screw platform

Locking Type	Size	Length	Platform
Multiaxial locking	5.0	14-120mm	T20
	4.0	14-95mm	
	5.0	10-120mm	
Cortex	4.5	14-150mm	T15
	3.5	10-120mm	
Cancellous	6.0	20-150mm	T8
	6.0	30-150mm	
	6.0	45-150mm	
Cable plug washers	3.5	10-120mm	T15
	4.0	10-100mm	
	4.0	10-100mm	
Cable plug washers	2.7	8-80mm	T8
	2.7	8-80mm	

Material considerations

Stryker Orthopedic Modeling and Analytics (SOMA)

Features and benefits

Variable angle locking

Material considerations



Fatigue strength

Pangea's anatomic and utility plates are made of type II anodized titanium (Ti6Al4V). This type II anodization provides up to a 17% increase in fatigue strength compared to non-anodized titanium.¹⁷

High fatigue strength is important for the implant to withstand repetitive cyclic loading. Cyclic loading of the implant is clinically generated during post-operative walking until fracture consolidation is achieved.

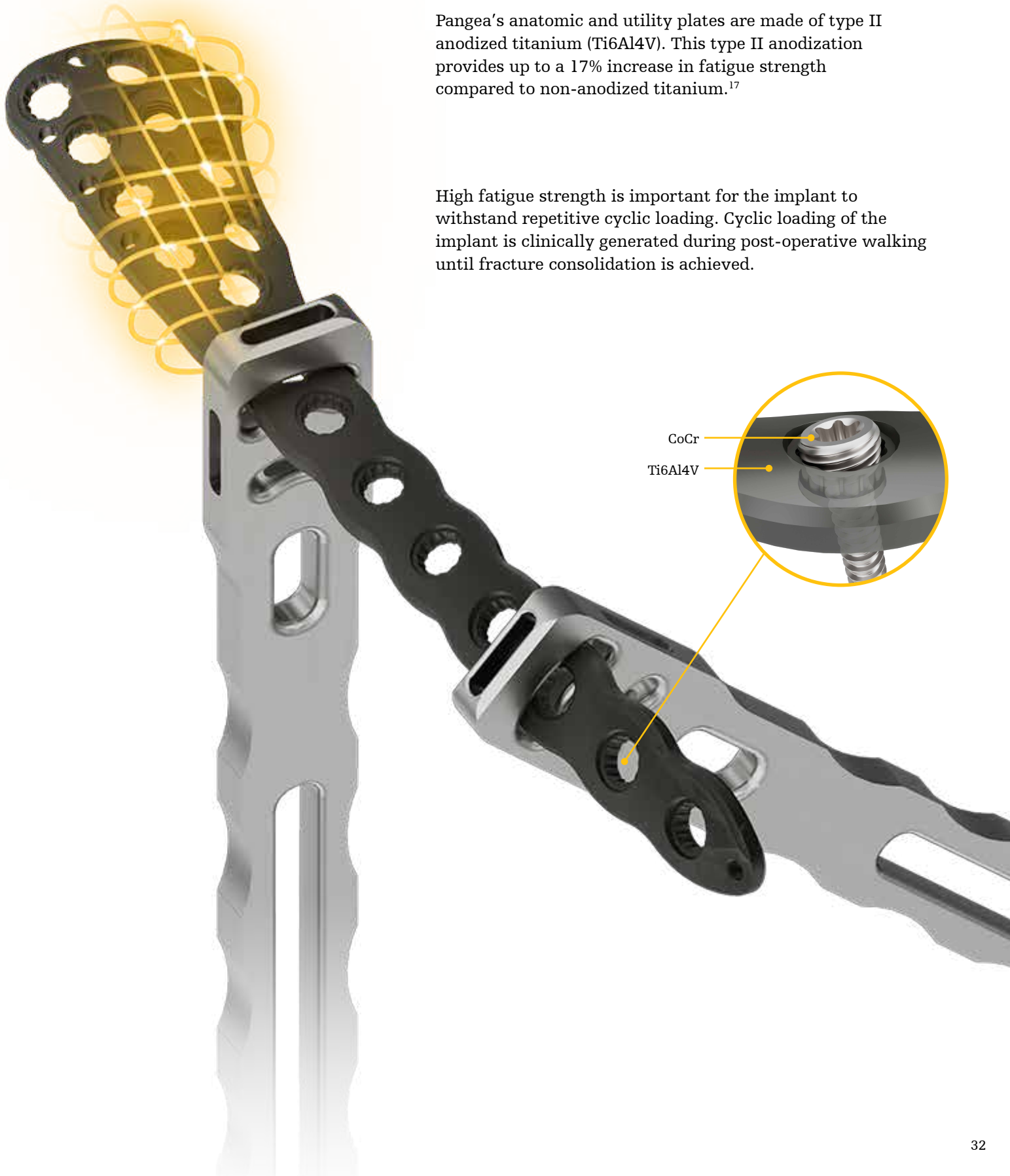

Modulus of elasticity

Stryker's titanium alloy has a low modulus of elasticity that allows for interfragmentary movement, which is known to influence callus formation - an important step in bone healing.¹⁸ Titanium's modulus of elasticity is closer to that of bone than stainless steel.^{19,20,21}

- Commercially pure titanium (CP-Ti) grade 2 and Ti6Al4V have a modulus of elasticity of 100-110 GPa and 100-130 GPa respectively.
- 316L stainless steel has a Young's modulus of 200 GPa.²²
- The greater elasticity of titanium allows for more implant flexibility which directly affects callus formation.
- Interfragmentary motion in the millimeter range is proven to induce bone healing that does not occur with less motion.²³
- In comminuted fractures treated with bridge plating, the fracture must heal with external callus formation.²¹

Significant Independent Risk Factors of Nonunion

Clinically, a retrospective multicenter case-control study concluded that the use of stainless steel plates can be identified as an independent predictor of nonunion risk.²⁴

- Rodriguez et al. identified 28 nonunions (13.3%) in a series of 283 supracondylar fractures across three level 1 trauma centers.²⁴
- Besides the use of stainless steel plates, obesity (BMI > 30), open fractures, and infection were identified as significant independent risk factors (P < 0.01).²⁴

Simplicity

You deserve the confidence that comes from a simple, innovative, and comprehensive system. The orthopedic surgeons behind Pangea knew this from experience, so that's what we created. Embrace the simplicity of a global platform, providing **everything you need and nothing you don't.**



One comprehensive portfolio

Pangea is a new force in plating—for hospitals, surgeons and staff

T8 T15 Pangea Small Fragment Core Tray

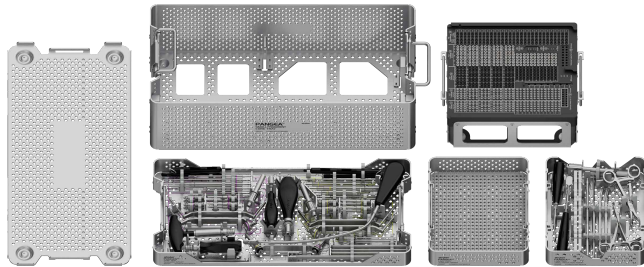

T20 Pangea Large Fragment Core Tray

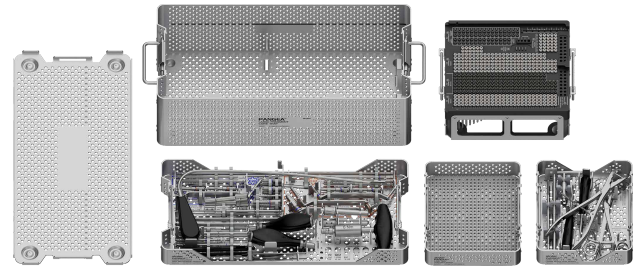

Plate Option



Anatomical

Proximal Humerus		●	
Proximal Humerus Posterior		●	
Extra Articular Distal Humerus		●	
Distal Lateral Femur			●
5.0 Distal Medial Femur			●
3.5 Distal Medial Femur		●	
PeriPRO Proximal Femur			●
PeriPRO Distal Femur			●
PeriPRO Interprosthetic Femur			●
Proximal Lateral Tibia		●	
Partial Articular Proximal Tibia		●	
Extra Articular Proximal Tibia			●
Proximal Medial Tibia		●	
Proximal Posteromedial Tibia		●	
Distal Anterolateral Tibia	●	●	
Distal Medial Tibia	●	●	
Distal Posterior Tibia	●	●	
Distal Lateral Fibula	●	●	
Distal Posterolateral Fibula	●	●	
Distal Posterior Fibula	●		

Plate Option



Utility

Narrow Straight	●	●	●
Broad Straight	●	●	●
Narrow Curved		●	
Broad Curved			●
1/3 Tubular		●	
Hook	●	●	
T-Plate	●	●	

Personalization and standardization

The Pangea small and large fragment core trays are designed to offer users modularity in their set configurations. Each core tray's standard configuration includes an auxiliary tray with a silicone mat for storage of miscellaneous instrumentation.

	Auxiliary insert with silicone mat	Small fragment reduction insert	Large fragment reduction insert	Asnis III 4.0mm cannulated screw insert
Small fragment core tray	✓	✓		✓
Large fragment core tray	✓		✓	✓

Optional insert configurations

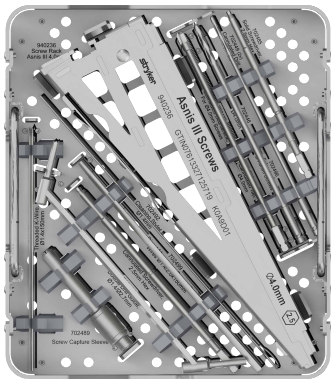

Asnis III 4.0mm cannulated screw insert

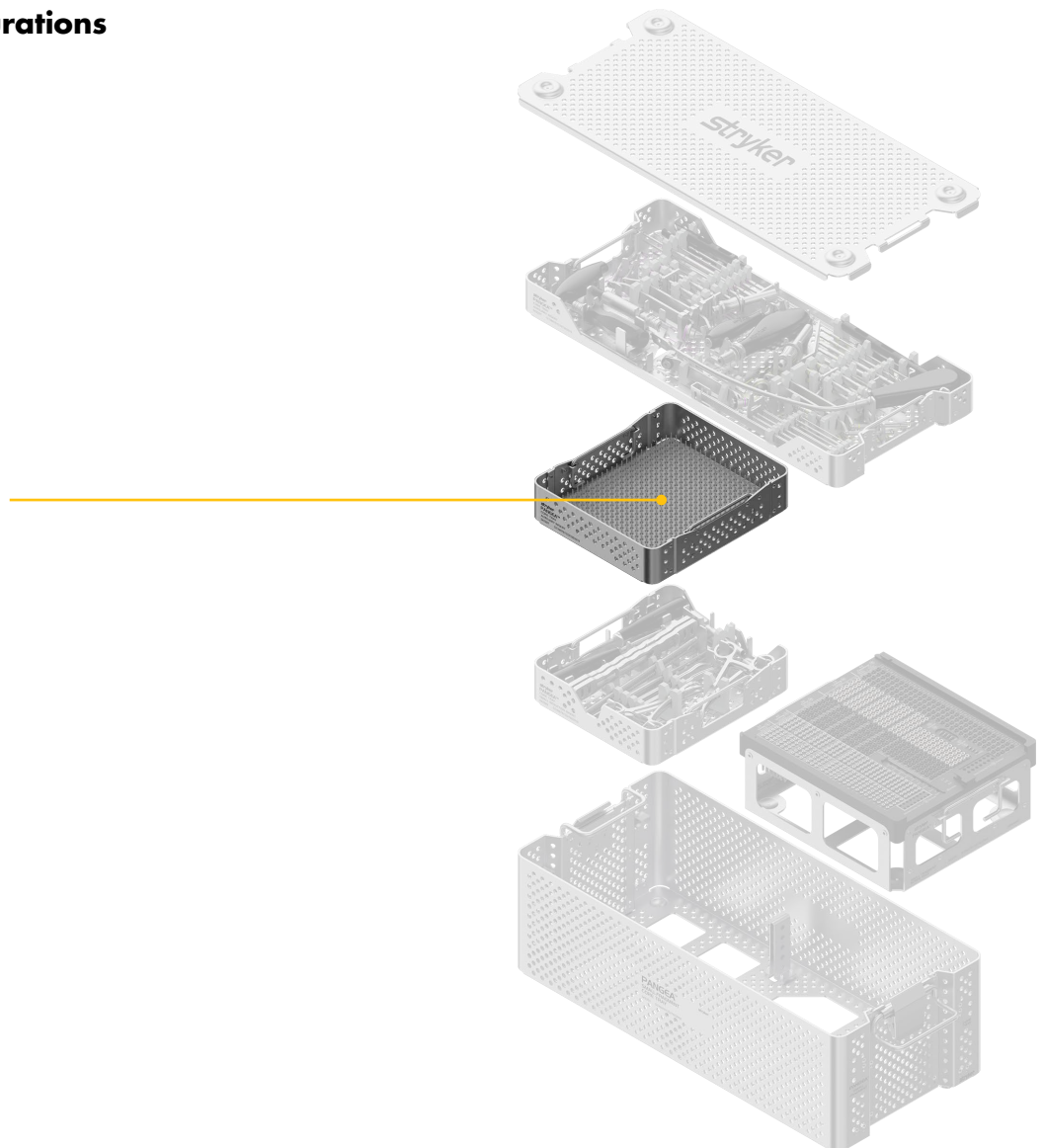

Color coded instrumentation

Despite various new plate options, all indication trays operate from the small fragment and large fragment core trays. Color coding helps to easily identify proper instrumentation for a particular plate and quickly differentiate screw sizes.

Small fragment

Ø 2.7mm Ø 3.5/4.0mm

Large fragment

Ø 4.0/4.5/6.0mm Ø 5.0mm

Small fragment core tray

Small fragment MIS Targeting Instruments Tray

Proximal Humerus Targeter Tray

3.5 Proximal Lateral Tibia Targeter Tray

Large fragment core tray

Large fragment MIS Targeting Instruments Tray

Distal Lateral Femur Targeter Tray

Extra-Articular Proximal Lateral Tibia Targeter Tray



Proximal Humerus



3.5 Proximal Lateral tibia



Distal Lateral Femur



5.0 Extra-Articular Proximal Lateral Tibia

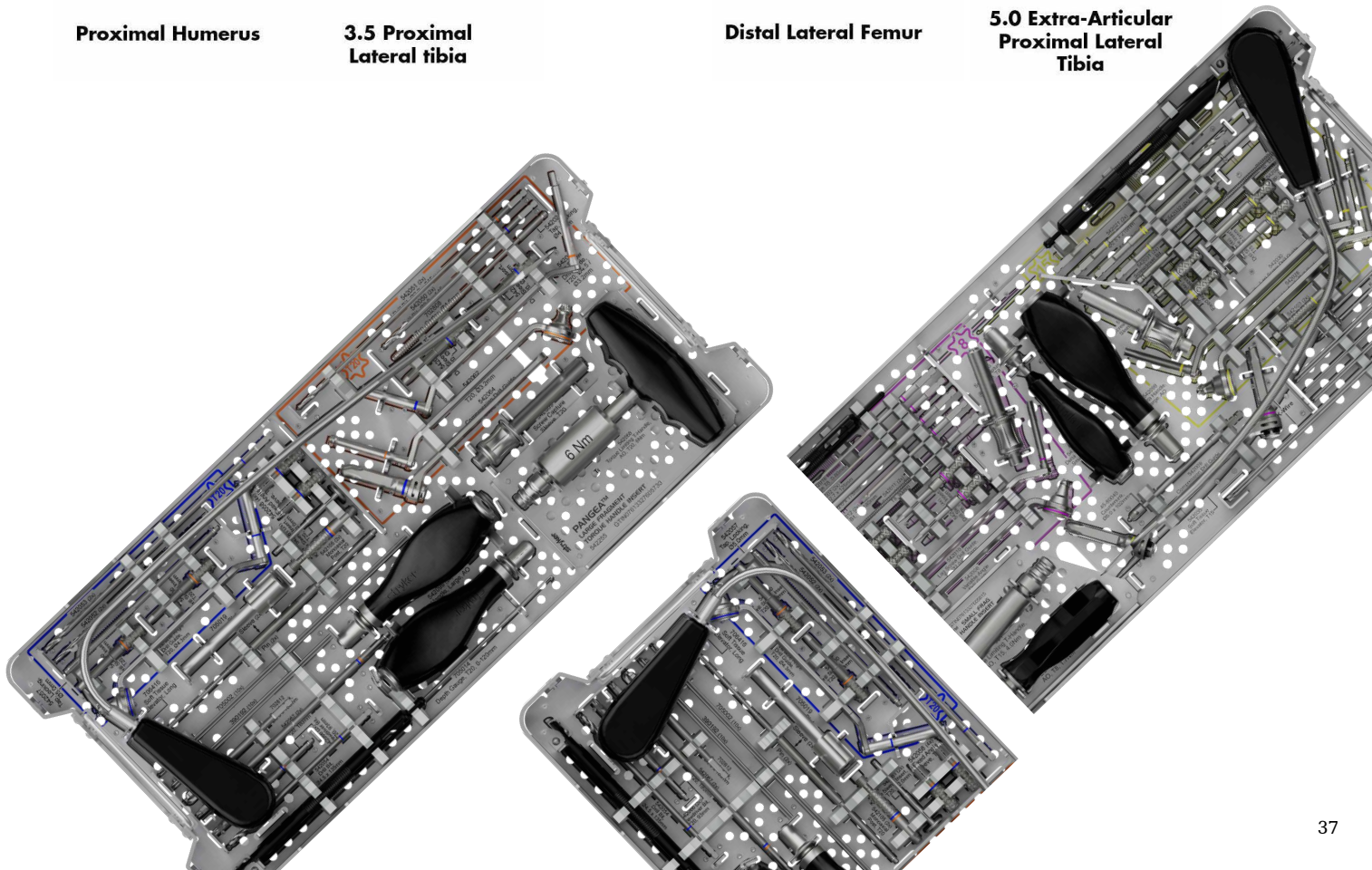

1. Internal Report No D0000262573, Rev AA
2. Frankle MA, Cordey J, et al. A retrospective analysis of plate contouring in the tibia using the conventional 4.5 (narrow) dynamic compression plate. *J Orthop Trauma*. 1994;8(1):59-63. doi: 10.1097/00005131-199402000-00013.
3. Theivendran K, Duggan PJ, et al. Surgical treatment of complex distal humeral fractures: functional outcome after internal fixation using precontoured anatomic plates. *J Shoulder Elbow Surg*. 2010;19(4):524-532. doi:10.1016/j.jse.2009.09.011
4. Hartel MJ, Naji T, et al. The influence of bone quality on radiological outcome in 50 consecutive acetabular fractures treated with a pre-contoured anatomic suprapectineal plate. *Arch Orthop Trauma Surg*. 2022;142(7):1539-1546. doi:10.1007/s00402-021-03867-3 (open access)
5. Chu CH, Chen YY, et al. Anatomic Locking Plate for Displaced Intraarticular Calcaneal Fracture: Design and Application. *J Foot Ankle Surg*. 2017;56(6):1165-1169. doi:10.1053/j.jfas.2017.05.030
6. Jian Z, Ao R, et al. A new anatomic locking plate for the treatment of posterolateral tibial plateau fractures. *BMC Musculoskelet Disord*. 2018;19(1):319. doi:10.1186/s12891-018-2216-2 (open access)
7. Capo JT, Debkowska MP, et al. Outcomes of distal humerus diaphyseal injuries fixed with a single-column anatomic plate. *Int Orthop*. 2014;38(5):1037-1043. doi:10.1007/s00264-013-2213-x (open access)
8. Song HK, Noh JW, et al. Avoiding rotational mismatch of locking distal tibia plates depends on proper plate position. *J Orthop Trauma*. 2013;27(7):e147-e151. doi:10.1097/BOT.0b013e31827cd67d
9. Hu C, Zhou K, et al. Application of pre-contoured anatomic locking plate for treatment of humerus split type greater tuberosity fractures: A prospective review of 68 cases with an average follow-up of 2.5 years. *Injury*. 2018;49(6):1108-1112. doi:10.1016/j.injury.2018.04.013
10. Bedard JC, Tanner S, et al. Analysis of the fit of modern pre-contoured distal femur plates: Expect an imperfect contour. *Injury*. 2020;51(3):719-722. doi:10.1016/j.injury.2020.01.009
11. Schmidt, W et al. "Stryker Orthopaedic Modeling and Analytics (SOMA): A Review." *Surgical Technology International*, vol. 32 (2018): 315-324.
12. Petersik A, Homeier A, et al. A numeric approach for anatomic plate design. *Injury*. 2018;49 Suppl 1:S96-S101. doi:10.1016/S0020-1383(18)30312-7
13. Internal report No D0000124129, Rev AF
14. Internal Report No D0000064652. Rev AA
15. Trompeter A, Christen A, et al. The influence of "kickstand" screws on the mechanical performance of a lateral distal femoral plate : a finite element analysis. *Bone Joint Res*. 2025;14(8):713-720. doi: 10.1302/2046-3758.148.BJR-2024-0479.R1
16. Fink, Jochen, 'Introduction to Stryker's SmartLock Technology BML & SOMA WebEx Sessions', content ID # VAX-EM-10_Rev-1 Feb 18th 2014
17. Internal Report No 300709CB1, 2010, Schönkirchen, Germany
18. Von Oldenburg G, Speitling A. Anodization of Titanium Implants – A Literature Summary. 2000, Monograph, Stryker Trauma AG
19. White Paper, AxSOS 3 Titanium Proximal Lateral Tibia Plate Stiffness and Strength, AxSOS-WP-1, Rev 1
20. Beltran, M. J., Collinge, C. A., & Gardner, M. J. (2016). Stress modulation of fracture fixation implants. *Journal of the American Academy of Orthopaedic Surgeons*, 24(10), 711-719.
21. Henderson CE, Herzog MA, et al. 2010 mid-America Orthopaedic Association Physician in Training Award: healing complications are common after locked plating for distal femur fractures. *Clin Orthop Relat Res*. 2011;469(6):1757-65. doi: 10.1007/s11999-011-1870-6.
22. Merk BR, Stern SH, et al. A fatigue life analysis of small fragment screws. *J Orthop Trauma*. 2001;15(7):494-9. doi: 10.1097/00005131-200109000-00006.
23. Beltran, M. J., Collinge, C. A., & Gardner, M. J. (2016). Stress modulation of fracture fixation implants. *Journal of the American Academy of Orthopaedic Surgeons*, 24(10), 711-719.
24. Rodriguez EK, Boulton C, et al. Predictive factors of distal femoral fracture nonunion after lateral locked plating: a retrospective multicenter case-control study of 283 fractures. *Injury*. 2014;45(3):554-559. doi:10.1016/j.injury.2013.10.042

This document is intended solely for the use of healthcare professionals. A surgeon must always rely on his or her own professional clinical judgment when deciding whether to use a particular product when treating a particular patient. Stryker does not dispense medical advice and recommends that surgeons be trained in the use of any particular product before using it in surgery.

The information presented is intended to demonstrate the breadth of Stryker product offerings. A surgeon must always refer to the package insert, product label and/or instructions for use, including the instructions for cleaning and sterilization (if applicable), before using any Stryker product. Products may not be available in all markets because product availability is subject to the regulatory and/or medical practices in individual markets. Please contact your Stryker representative if you have questions about the availability of Stryker products in your area.

The instructions for use, operative techniques, cleaning instructions, patient information leaflets and other associated labeling may be requested online at ifu.stryker.com or stryker.com. If saving the instructions for use, operative techniques, cleaning instructions from the above mentioned websites, please make sure you always have the most up to date version prior to use.

Stryker Corporation or its divisions or other corporate affiliated entities own, use or have applied for the following trademarks or service marks: Stryker, VariAx, and Pangea. All other trademarks are trademarks of their respective owners or holders.



Manufacturer:
Stryker GmbH
Bohnackerweg 1
2545 Selzach, Switzerland
stryker.com