

stryker

# Hoffmann® LRF

Hexapod

**Operative technique**



# Hoffmann LRF

## Contents

Indications and contraindications . . . . .	3
Warnings and precautions . . . . .	4
Introduction: Hoffmann LRF Hexapod . . . . .	5
Construct overview . . . . .	8
Hexapod strut . . . . .	8
Strut identification . . . . .	10
Rings and mounting locations . . . . .	11
General pre-build procedure . . . . .	15
Strut offsetting . . . . .	20
Pre-op planning . . . . .	23
Construct application . . . . .	26
Strut repositioning and change-out procedure . . . . .	35
Patient adjustments . . . . .	39
Construct examples . . . . .	40

## Acknowledgments

This publication sets forth detailed recommended procedures for using Stryker devices and instruments. It offers guidance that you should heed, but, as with any such technical guide, each surgeon must consider the particular needs of each patient and make appropriate adjustments when and as required.

A workshop training is recommended prior to performing your first surgery.

**WARNING**

Follow the instructions provided in our cleaning and sterilization guide (OT-RG-1). All non-sterile devices must be cleaned and sterilized before use.

**WARNING**

Multicomponent instruments must be disassembled for cleaning. Please refer to the corresponding assembly/disassembly instructions.

Please remember that the compatibility of different product systems has not been tested unless specified otherwise in the product labeling.

Consult Instructions for Use ([www.ifu.stryker.com](http://www.ifu.stryker.com)) for a complete list of potential adverse effects, contraindications, warnings and precautions.

**WARNING**

- The surgeon must warn patients of surgical risks, and make them aware of possible adverse effects.
- The patient should be warned that the device cannot and does not replicate a normal healthy bone, that the device can break or become damaged as a result of strenuous activity or trauma, malunion or nonunion.
- The surgeon must warn the patient that the device has a finite expected service life and may need to be removed at some time in the future.

**NOTICE**

This operative guide contains information specific to the Hoffmann LRF Hexapod. For a complete overview of the entire Hoffmann LRF System, it is recommended that the user also references the Hoffmann LRF Circular External Fixation operative technique (H-ST-1), Hoffmann LRF Gradual Correction operative technique (H-ST-2), Hoffmann LRF Bone Transport operative technique (H-ST-31), the Patient Guide for External Fixation (H-PG-1), the Hoffmann LRF Hexapod Hole Offset Guide (H-ADI-1), and the Hoffmann LRF Web Application Software User's Manual (H-IFU-2).

# Indications and contraindications

## Indications for use (Europe and other countries)

The Hoffmann LRF System is indicated in (upper and lower) extremities for the treatment and fixation of:

- Open and closed Fractures.
- Post-traumatic joint contracture which has resulted in loss of range of motion.
- Fractures and disease which generally may result in joint contractures or loss of range of motion and fractures requiring distraction.
- Pseudoarthrosis or non-union of long bones.
- Limb lengthening by epiphyseal or metaphyseal distraction.
- Correction of bony or soft tissue deformity.
- Correction of segmental bony or soft tissue defects.
- Joint arthrodesis.
- Bone transport.
- Osteotomy.
- Revision procedure where other treatments or devices have been unsuccessful.
- Bone reconstruction procedures.
- Foot Fusion.
- Charcot foot reconstruction.
- Lisfranc dislocations.

## Contraindications

Since external fixation devices are often used in emergency situations to treat patients with acute injuries, there are no absolute contraindications for use. The surgeon's education, training and professional judgment must be relied upon to choose the most appropriate device and treatment for each individual patient.

Whenever possible, the device chosen should be of a type indicated for the fracture being treated and/or for the procedure being utilized.

## Conditions presenting an increased risk of failure include:

- Insufficient quantity or quality of bone which would inhibit appropriate fixation of the device.
- Compromised vascularity that would inhibit adequate blood supply to the fracture or operative site.
- Previous history of infections.
- Any neuromuscular deficit which could interfere with the patient's ability to limit weight bearing.
- Any neuromuscular deficit which places an unusually heavy load on the device during the healing period.
- Malignancy in the fracture area.
- Mental, physical, or neurological conditions which may impair the patient's ability to cooperate with the post-operative regimen.

The following factor is of extreme importance to the eventual success of the procedure:

## Patient's activity:



These devices are neither intended to carry the full load of the patient acutely, nor intended to carry a significant portion of the load for extended periods of time. For this reason post-operative instructions and warnings to patients are extremely important. If the patient's activity comprises significant impact loads (walking, running, lifting or turning) the resulting forces could lead to failure of the fixation, the system or both. The system will not restore function to the level expected with normal healthy bone, and the patient should not have unrealistic functional expectations.

# Warnings and precautions

## Indications for use (United States and Canada)

The Hoffmann LRF System is indicated in pediatric patients and adults for the treatment and fixation of:

- Open and closed fractures.
- Post-traumatic joint contracture which has resulted in loss of range of motion.
- Fractures and disease which generally may result in joint contractures or loss of range of motion and fractures requiring distraction.
- Pseudoarthrosis or non-union of long bones.
- Limb lengthening by epiphyseal, diaphyseal, or metaphyseal distraction.
- Correction of bony or soft tissue deformity.
- Correction of segmental bony or soft tissue defects.
- Joint arthrodesis.
- Management of communicated intra-articular fractures of the distal radius.
- Bone transport.

The Hoffmann LRF System is indicated in adults for:

- Osteotomy.
- Revision procedure where other treatments or devices have been unsuccessful.
- Bone reconstruction procedures.
- Fusions and replantations of the foot.
- Charcot foot reconstruction.
- Lisfranc dislocations.

## Warnings

### WARNING

Single use devices cannot be reused, as they are not designed to perform as intended after the first usage. Mechanical, physical or chemical properties may be compromised after first usage. In this case, the safety and performance of the devices is not supported by the manufacturer, compliance to relevant specifications cannot be ensured. External fixator devices have been designed for single patient use. Reuse of single-use external fixators may lead to reduced biomechanical properties and/or fatigue breakage of the devices. Do not reuse single-use external fixator components. Please refer to the device label to identify single or multiple use and / or re-sterilization release.

### WARNING

Take caution not to exert excessive tightening force on frame components as this may also compromise component integrity and performance.

### WARNING



The Hoffmann LRF System is MR unsafe.

## Precautions

Information for patient:

### CAUTION

Surgeons must instruct the patients to report any unusual changes of the operated site to their physician. Surgeon should immediately evaluate the patient if a change at the fracture site has been detected. The surgeon should evaluate the possibility of subsequent clinical failure, and discuss with the patient the need for reduced activity levels, and / or possible revision surgery in order to aid fracture healing.

### CAUTION

The surgeon should discuss all physical and psychological limitations inherent in the use of external fracture fixation appliances with the patient. Particular attention should be given to premature weight bearing, activity levels and the necessity for periodic medical follow-up.

### NOTICE

Components of the following systems may be used with the Hoffmann LRF system: Monticelli-Spinelli External Fixation system, Apex Pins, Trauma Pelvic set, Hoffmann II External Fixation system, Hoffmann 3 External Fixation system, Hoffmann II External Fixation system 90° Post, Hoffmann II Miami Post, Hoffmann II Carbon Connecting Rods, Hoffmann II MRI External Fixation system, and Hoffmann II Compact MRI External Fixation system.

# Introduction

The Hoffmann LRF Hexapod adds additional deformity correction utility to the Hoffmann Limb Reconstruction Frame (LRF) platform.

The LRF Hexapod strut is a modified version of the Gradual Correction Telescopic Motor. With the universal hinge now integrated into the strut's design, six struts can be configured into the hexapod configuration to create a virtual hinge construct to effect multiple axes of correction.



**Hoffmann LRF Hexapod construct**



## **NOTICE**

Hexapod Struts are slightly different than the modular Gradual Correction Telescopic Motors. The Hexapod Struts are designed with a built-in universal hinge and have a re-calibrated scale for use with the Hoffmann LRF Web Application. Hexapod struts are to be used in a hexapod construct configuration only.

# Introduction

The core Hoffmann LRF universal components, including aluminum and carbon fiber rings, pin and wire fixation, and instrumentation, provide the remaining components for construct assembly.

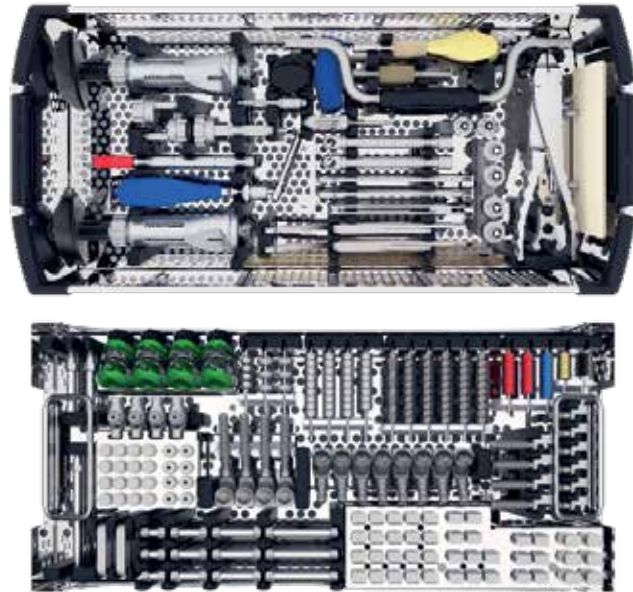

Additional construct flexibility achieved with strut offsetting allows the user to relocate struts away from their nominal attachment sites. Strut offsetting may allow for the surgeon to work around existing fixation components, and may negate the need for strut change-outs in certain instances, as struts can be repositioned in adjacent holes to reclaim strut stroke length.



# Introduction

Complemented by case planning and management tools offered in the Hoffmann LRF Web Application ([www.fixmyleg.stryker.com](http://www.fixmyleg.stryker.com)), the LRF Hexapod is designed to address a range of deformities and complex limb reconstruction procedures.

Refer to the Hoffmann LRF Hexapod Web Application Software User's Manual (H-IFU-2) for comprehensive instructions for the software.

**stryker**
**Hoffmann Limb Reconstruction Frame**

BROWSER COMPATIBILITY | CHANGE PASSWORD | CONTACT US | SETTINGS | DISCLAIMER | HELP | SIGN OUT

My dashboard | Case details | Deformity definition | Ring configuration | **STRUT CONFIGURATION** | LAS input | Correction plan | Study report

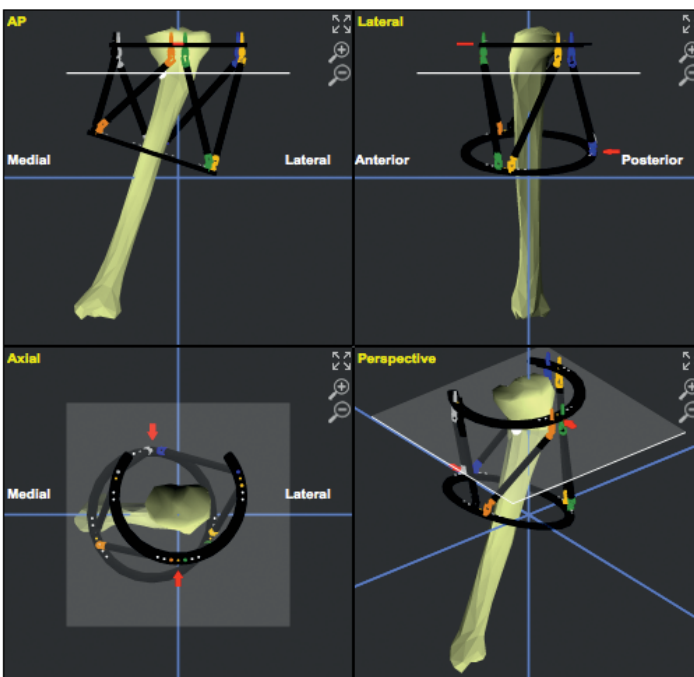

AP offset Medial  28.5 mm ?

Lateral offset Anterior  0 mm ?

Axial offset Proximal  0 mm ?

Max. distraction rate  ?  
(mm/day)

CALCULATE CORRECTION TIME

Correction time  (days)

Override correction time with  (days) ?

\* The bone models used in the software application can be manipulated to create a graphical representation of the anatomy being treated. This graphical representation is intended to mimic the general anatomy of the deformed bone, and is not meant to include any patient-specific bone characteristics.

OPAQUE

GRID

SAVE

RESET

PREVIOUS

NEXT

# Construct overview

## Hexapod strut

When assembled into the hexapod configuration, struts are designed to provide a range of motion capable of correcting three-dimensional deformities.

Quick release features allow the construct to be unlocked for rapid, gross manipulation and secure primary and secondary locking features are designed to reduce the risk of inadvertent strut adjustment postoperatively. To facilitate routine construct adjustments, the strut is designed with a top-down actuation point which is typically mounted on the proximal reference ring. The clicking mechanism incorporated into the strut's universal joint permits adjustments in 1/4mm increments and allows the user to modulate the rate of adjustment specifically to the patient's indications.

A pronounced audible, tactile, and visual confirmation of an adjustment is produced by the clicking mechanism, which provides feedback to the patient that an adjustment has been made. The strut's threaded portion accommodates small ball-bearings housed in the quick release mechanism. This is designed to reduce friction in the mechanism and is intended to facilitate adjustments.

**CAUTION**

To maintain intended performance, Hexapod struts should not be re-sterilized beyond 100 autoclave cycles.

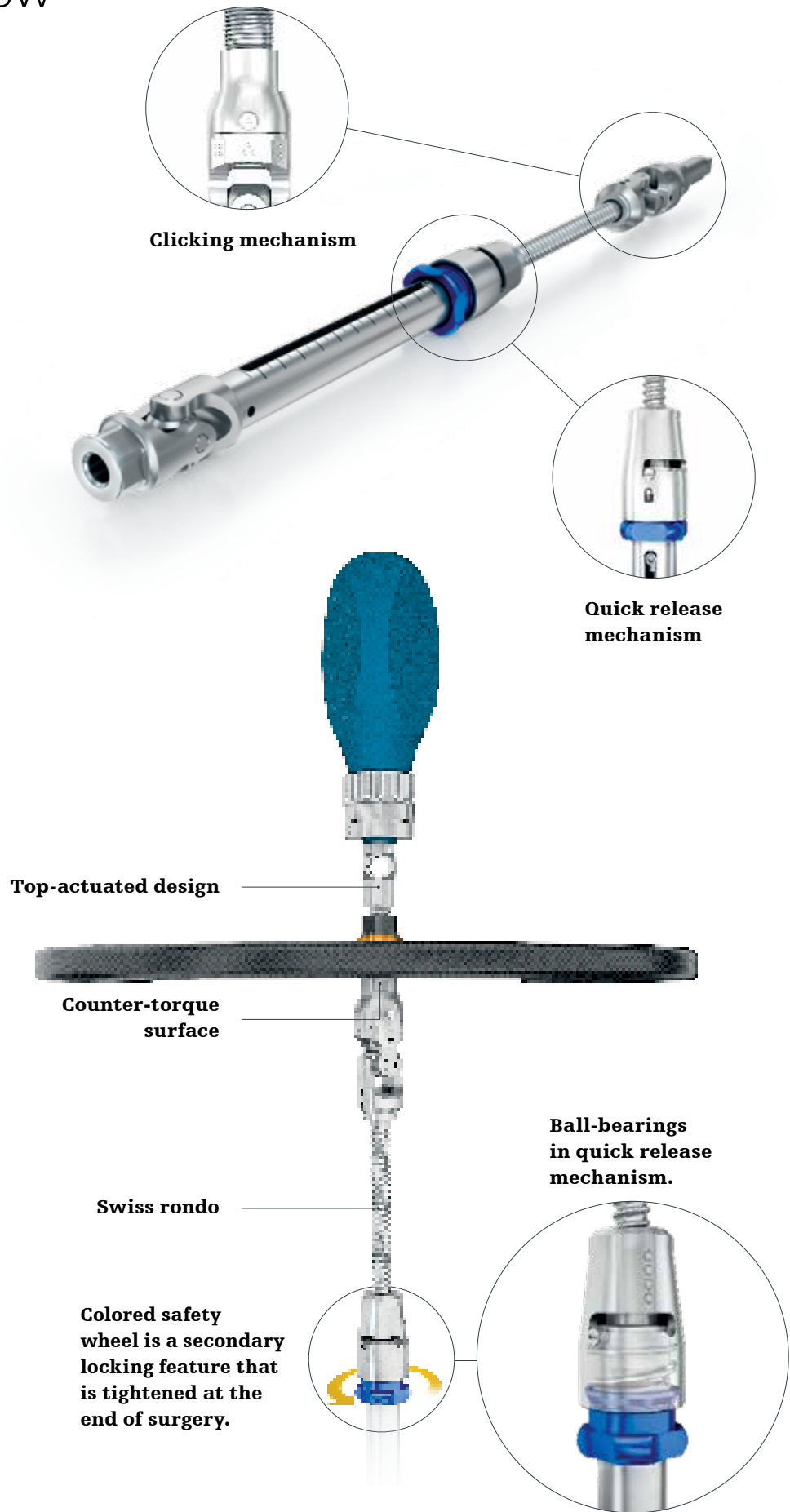

# Construct overview

## Struts

Sizes (u-joint to u-joint):

- Extra short: 89–109mm (20mm of travel)
- Short: 105–139mm (34mm of travel)
- Medium: 131–191mm (60mm of travel)
- Long: 183–295mm (112mm of travel)

### NOTICE

The colors of the safety wheel do not indicate the strut's number or location on the construct. The color coding denotes strut size only (red: large strut, blue: medium strut, yellow: short strut, black: extra short strut).

### NOTICE

The strut's clicking universal joint is designed with a 60° angulation limit to prevent frame configurations that cannot be actuated by the user.

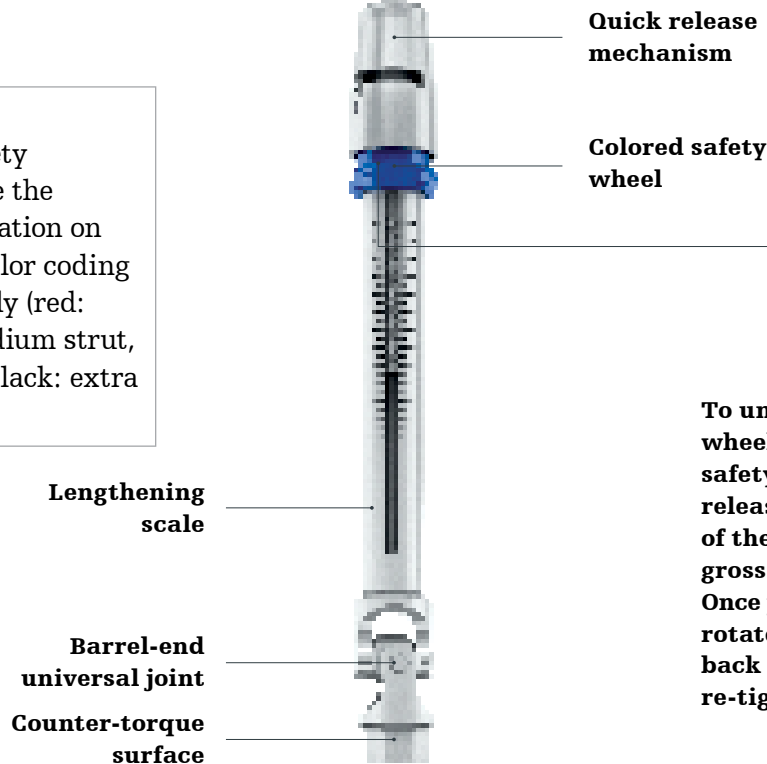

To unlock, loosen the colored safety wheel to the etched line. Once the safety wheel is loosened, the quick release housing can be rotated out of the locked position, enabling gross telescopic length adjustment. Once proper strut length is achieved, rotate the quick release housing back into the locked position and re-tighten colored safety wheel.

Universal joints do not swivel, which may help to reduce unwanted construct play and rattle.

M6 connecting bolt

### CAUTION

To avoid inadvertent disassembly of the quick release mechanism, do not loosen the colored safety nut beyond the etched line.

If the colored safety nut is accidentally loosened beyond the etched line and the mechanism disassembles, simply push the colored safety nut and spring

back into the quick release body and re-tighten the nut with clockwise turns until the assembly reengages.

# Construct overview

## Strut identification

The ID clips number each strut and are used by the patient and caregiver to identify specific struts for adjustment in accordance with the correction plan.

ID clips are applied during frame assembly between the ring and the connecting nut (M8). This prevents them from inadvertently detaching from the frame during the course of treatment.

**CAUTION**

It is imperative that the ID clips are attached to the correct struts during frame assembly. This can occur during pre-building of the frame or as each strut is attached intraoperatively. The bent flange on the ID clip is designed to wrap around the edge of the ring's inner diameter. This will prevent the ID clip from rotating during tightening and will also orient the ID clip and ID clip numbering in a fashion that is easy to decipher by the patient. ID clips are not to be mounted on the distal (non-clicking) end of the strut.

"+" (lengthen) and "-" (shorten) directional arrows are also marked on the ID clips and indicate clockwise / counter-clockwise adjustment in accordance with the patient's correction plan.

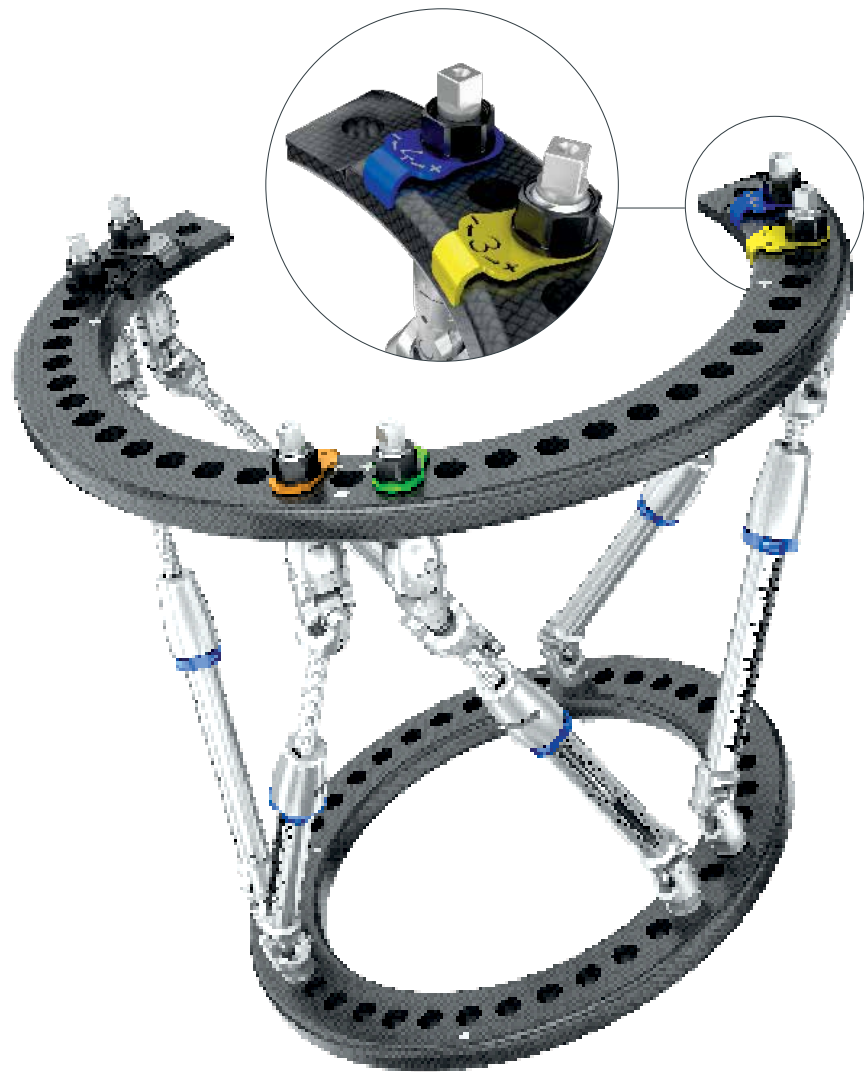

# Construct overview

## Rings and mounting locations

Hoffmann LRF Rings are offered in anodized aluminum as well as radiolucent carbon fiber reinforced polymer.

Ring diameters range from 80mm – 270mm and are offered in full, open, and segment ring geometries. Short and long foot rings are also available with corresponding variable angle foot arches for closure.



### Carbon

Full ring	Open ring / segment	Foot ring (long)	Foot ring (short)
Ø80mm	Ø100mm	Ø100mm	Ø100mm
Ø100mm	Ø120mm	Ø120mm	Ø120mm
Ø120mm	Ø140mm	Ø140mm	Ø140mm
Ø140mm	Ø155mm	Ø155mm	Ø155mm
Ø155mm	Ø180mm	Ø180mm	Ø180mm
Ø180mm	Ø210mm	Ø210mm	Ø210mm
Ø210mm			

### Aluminum

Full ring	Open ring / segment	Foot ring (long)	Foot ring (short)
Ø80mm	Ø100mm	Ø100mm	Ø100mm
Ø100mm	Ø120mm	Ø120mm	Ø120mm
Ø120mm	Ø140mm	Ø140mm	Ø140mm
Ø140mm	Ø155mm	Ø155mm	Ø155mm
Ø155mm	Ø180mm	Ø180mm	Ø180mm
Ø180mm	Ø210mm	Ø210mm	Ø210mm
Ø210mm	Ø240mm		
Ø240mm			
Ø270mm			

# Construct overview

## Rings and mounting locations (continued)

Hoffmann LRF Rings feature 2 sets of markings. When used in the hexapod configuration, the triangle markings ▲ are referenced. The struts mount into the holes immediately adjacent to the hole with the triangle marking. In the nominal position, struts should straddle this marking, with a minimum of one open hole in between two adjacent struts.

The master marking featuring the ◀▲ symbol identifies the nominal attachment site for struts 1 and 2. Moving counter-clockwise, struts 3, 4, 5 and 6 are mounted adjacent to the remaining two triangle markers.

**NOTICE**  
Strut mounting sites vary depending on the ring type selected.



**Nominal strut mounting sites:  
full ring (reference ring).**



# Construct overview

Foot ring shown as the distal moving ring. Full circular ring shown as the proximal reference ring.

**CAUTION**

Master markers on reference and moving ring must be rotated 180° to each other before introducing a rotatory ring offset to address a rotational deformity.

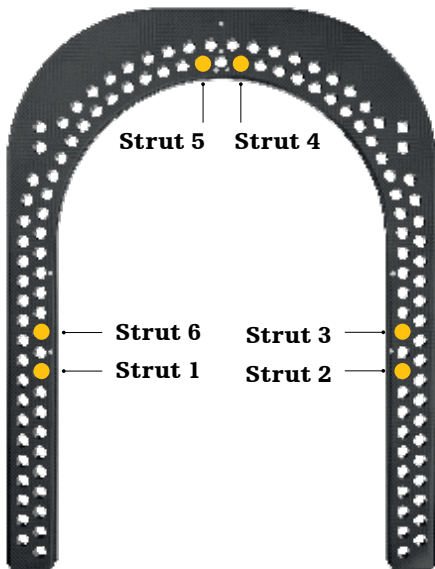
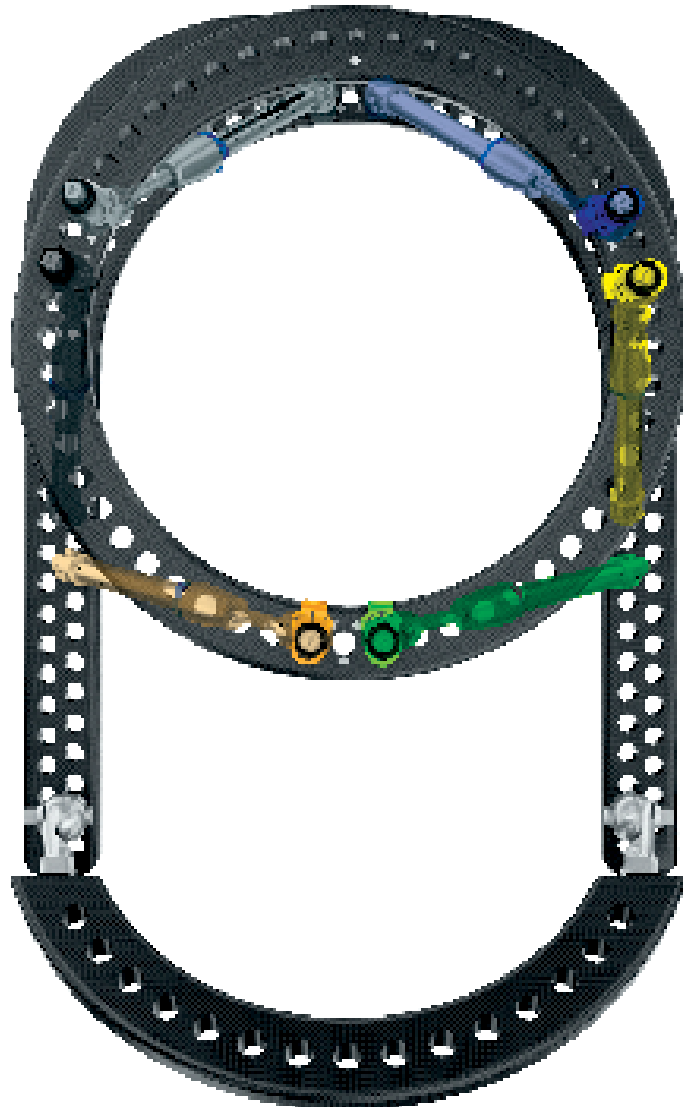

**Nominal strut mounting sites:  
foot ring.**

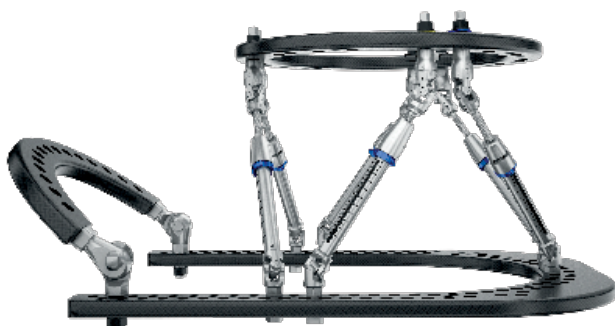

## Construct overview

When using an open reference ring, strut pairs 3 and 4, and 5 and 6 are offset from the triangle markers by one hole. Struts 3 and 4 are each offset clockwise one hole. Struts 5 and 6 are each offset by one hole counter-clockwise. Unless specified by the software, struts 4 and 5 will be attached directly to the holes marked with the triangle symbol when using open ring types.

### NOTICE

The LRF Web Application is set to recognize the specific mounting sites shown here as the "nominal" for open rings.

### CAUTION

Constructs with two open rings have not been mechanically evaluated and are not recommended.



**Nominal strut mounting sites:  
open reference ring.**



# General pre-build procedure

Select specific ring and strut types and sizes as per indication.



Example shown:

- (2) Carbon fiber rings
- (6) Hexapod struts
- (6) M8 connecting nuts
- (6) M6 connecting bolts
- (1) Set of 6 strut ID clips
- (2) Wrenches



# General pre-build procedure

## Step 1

Insert the actuator end of strut 1 through the ring hole immediately clockwise to the master marker . Before definitively securing with an M8 connecting nut, seat the corresponding  ID clip 1 (orange) over the actuation post so that it sits flush against the superior surface of the ring.

### NOTICE

Due to slight variances between the carbon and aluminum ring geometries, the ID clip lip may seat slightly prominent off the inner ring surface on certain ring types.

With a counter-torque wrench in place, apply an M8 connecting nut and secure the strut and ID clip in position. Special attention should be paid to ensure that the ID clip is placed on the correct strut.

ID clips must be mounted on the adjustment side of the construct (typically proximal ring).

### NOTICE



Do not mount ID clips on the barrel end of the strut.



**Before attempting to actuate the strut, ensure that it is definitively tightened to the ring.**

# General pre-build procedure

## Step 2





Moving counter-clockwise, insert strut 2  on the other side of the master marker . Apply ID clip 2 before securing the strut with a connecting nut (M8).

### NOTICE

Always ensure that there is at least one open hole between two adjacent struts.



## General pre-build procedure

Continuing counter-clockwise, locate the 2nd triangle marker and attach struts 3  and 4  followed by 5  and 6  at the 3rd triangle marker in the same fashion.

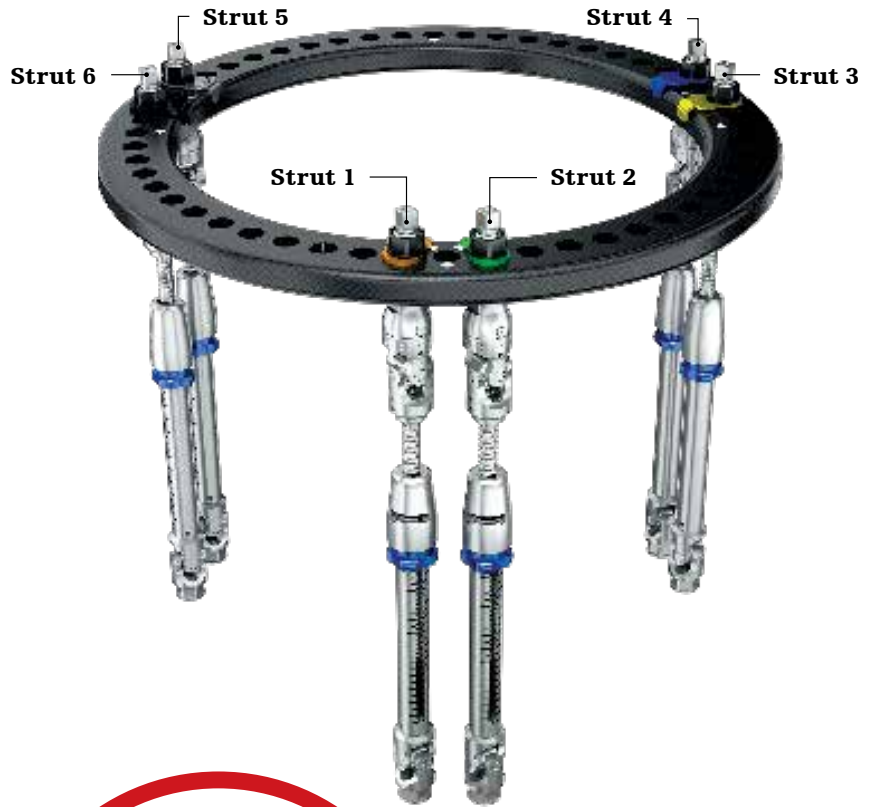

### Step 3

Confirm struts 1 through 6 are securely affixed to the ring with counter-torque. In the nominal locations, even numbered struts (2, 4, 6) should be attached counter-clockwise of the triangle markers and odd numbered struts (1, 3, 5) should be attached clockwise of the triangle markers.

#### NOTICE

Although it is recommended that the actuating end of each strut is attached to a proximal reference ring for easy patient access, strut orientation does not dictate the location of the reference ring.

Either ring can be selected as a reference or moving ring regardless of strut orientation

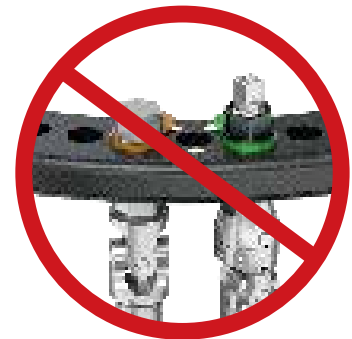

#### CAUTION

All struts must be attached uniformly, with the actuating ends of all six struts attached to the same ring.

# General pre-build procedure

## Step 4

The moving ring can now be attached to complete the core dynamic construct.

### CAUTION

Before attaching the struts at the nominal mounting sites, axially rotate the moving ring so that the master marker  is positioned 180° in relation to the reference ring before introducing a rotatory ring offset to address a rotational deformity.

Using counter-torque, attach the second ring to the struts with M6 connecting bolts. The barrel end of struts 4 and 5 should straddle the master marking on the moving ring. Struts 6 and 1 and 2 and 3 should straddle the remaining triangle markings on the moving ring.

### CAUTION

Before definitively locking the barrel end of the strut to the ring, be sure that the lengthening scale is facing outward for easy reference.

### CAUTION

Do not use washers or long connection bolts when attaching the struts to the ring.

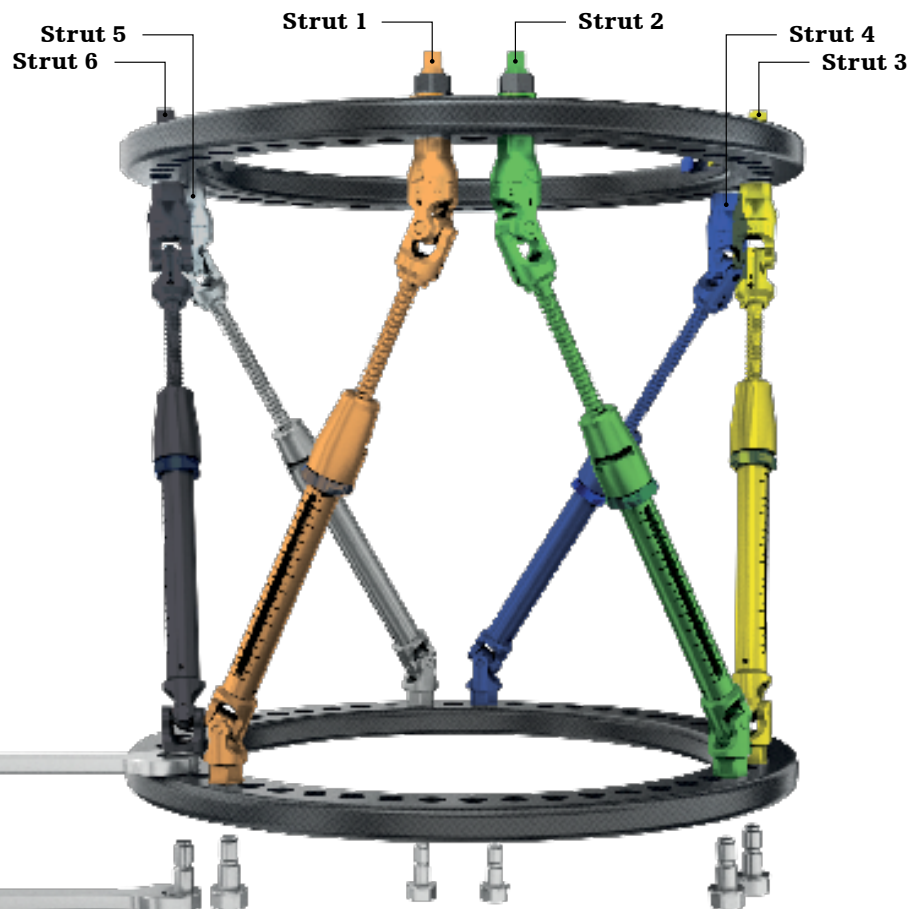
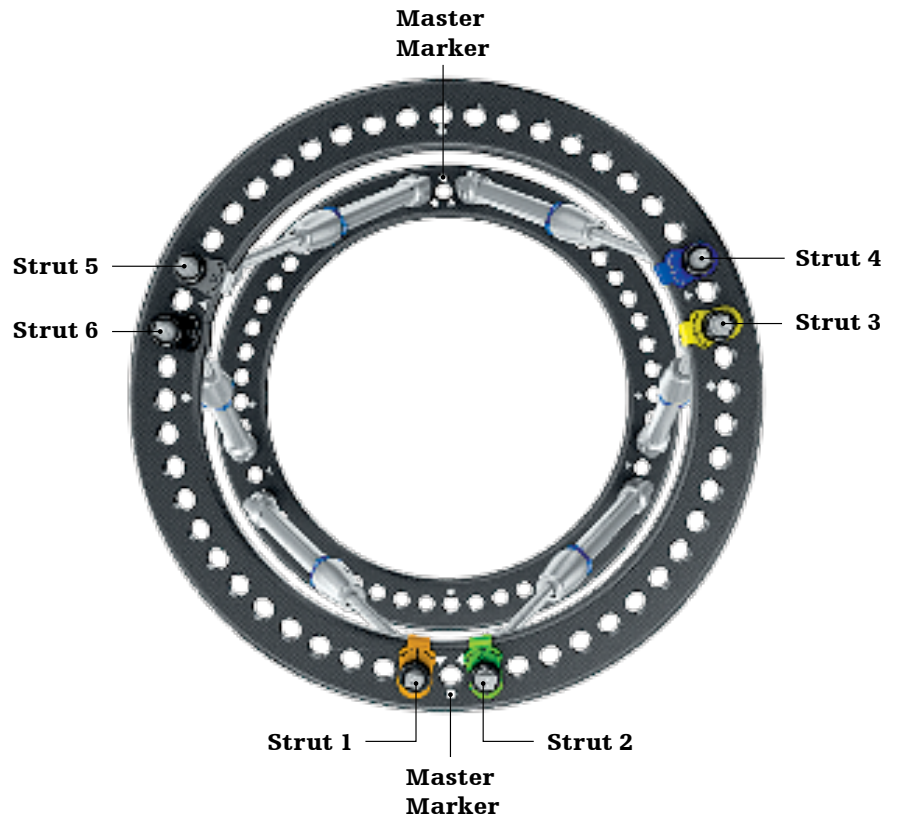

# Strut offsetting

## Overview

The Hoffmann LRF Hexapod System allows additional construct adaptability. If required, users can position struts up to 2 holes away from their nominal attachment sites. Once final strut placement is determined, the user can input a strut's specific mounting parameters into the web application to adjust the correction algorithm accordingly. The offset feature is designed to provide more freedom in strut placement and construct design and allows flexibility when working around fixation sites and other frame components.

### CAUTION

Smaller ring diameters (80mm-140mm) only allow for offsetting one hole away from their nominal attachment sites.

### NOTICE

Always ensure that there is at least one open hole between two adjacent struts.

### NOTICE

Struts can be offset and attached in specific holes away from their nominal attachment sites in both directions (see Hole offset guide H-ADI-1 for strut offset capabilities for each ring size). This may be calculated preoperatively and planned with software guidance or be performed intraoperatively as dictated by the surgical scenario.

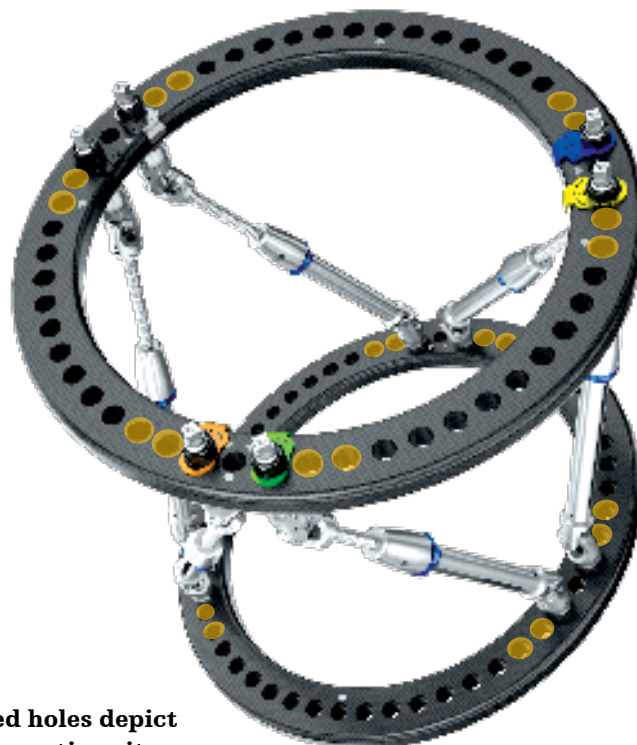
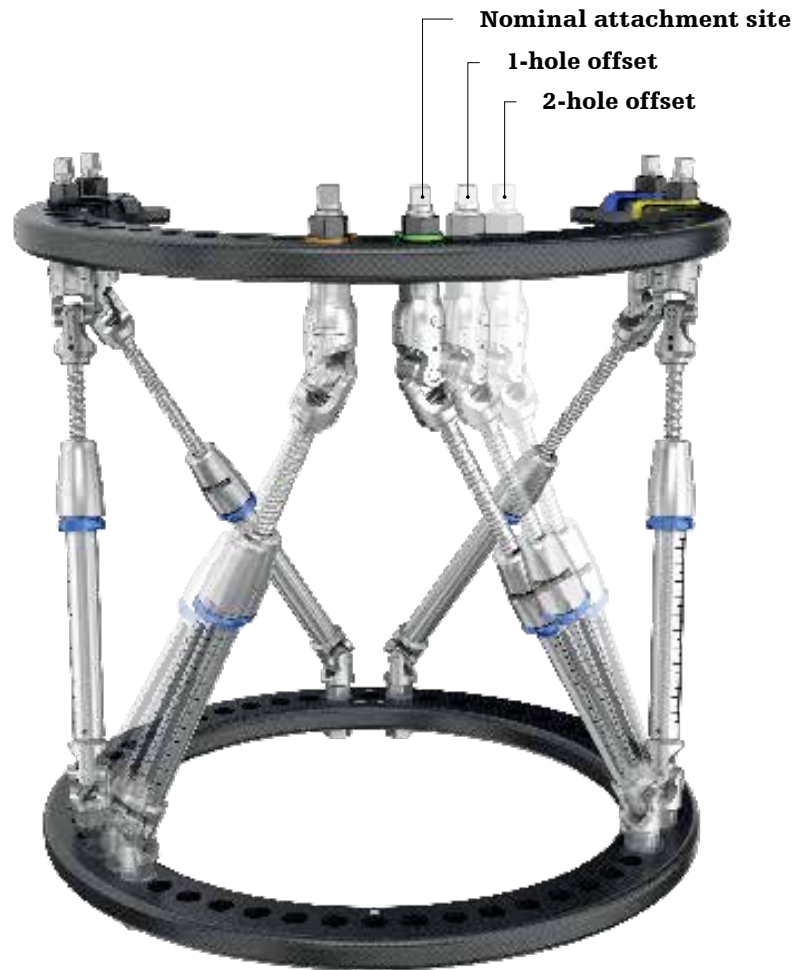

Highlighted holes depict alternative strut mounting sites.

# Strut offsetting

## Offsetting examples

Offsets can occur in both clockwise and counter-clockwise directions as long as a minimum of one hole separates a pair of adjacent struts.

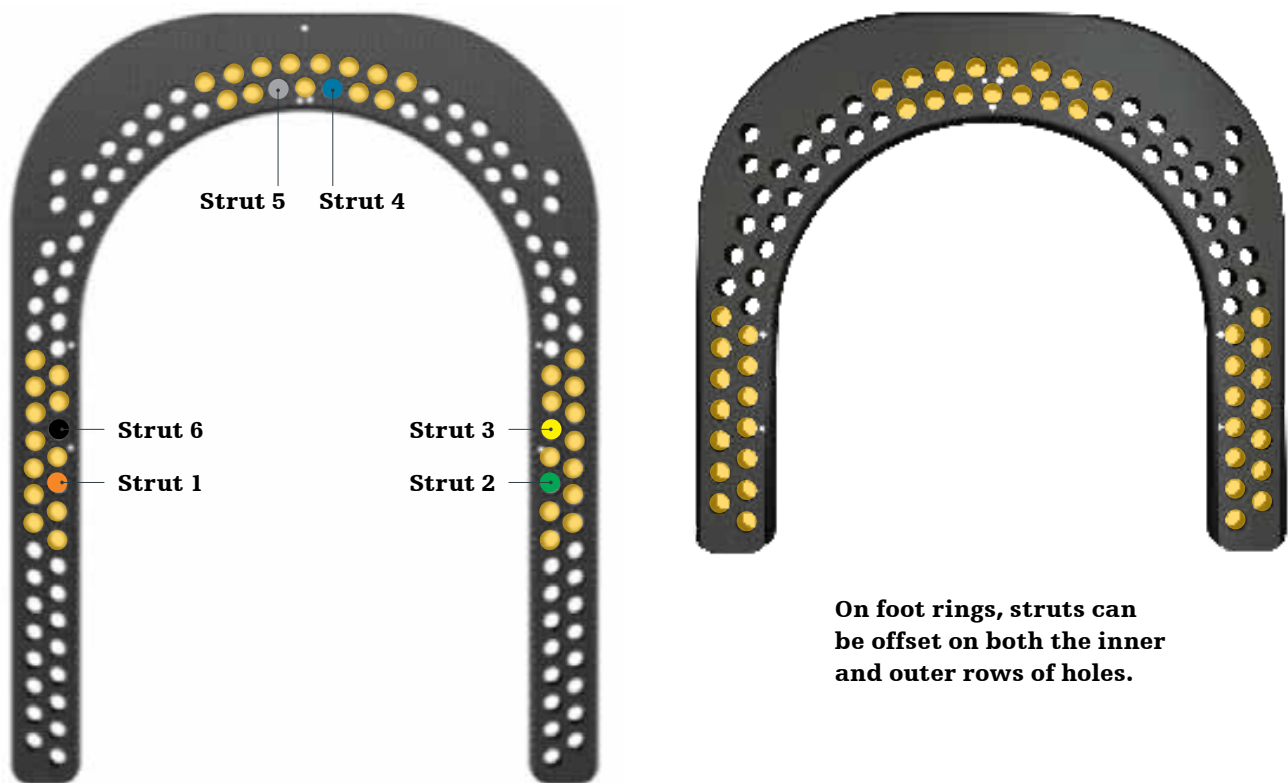
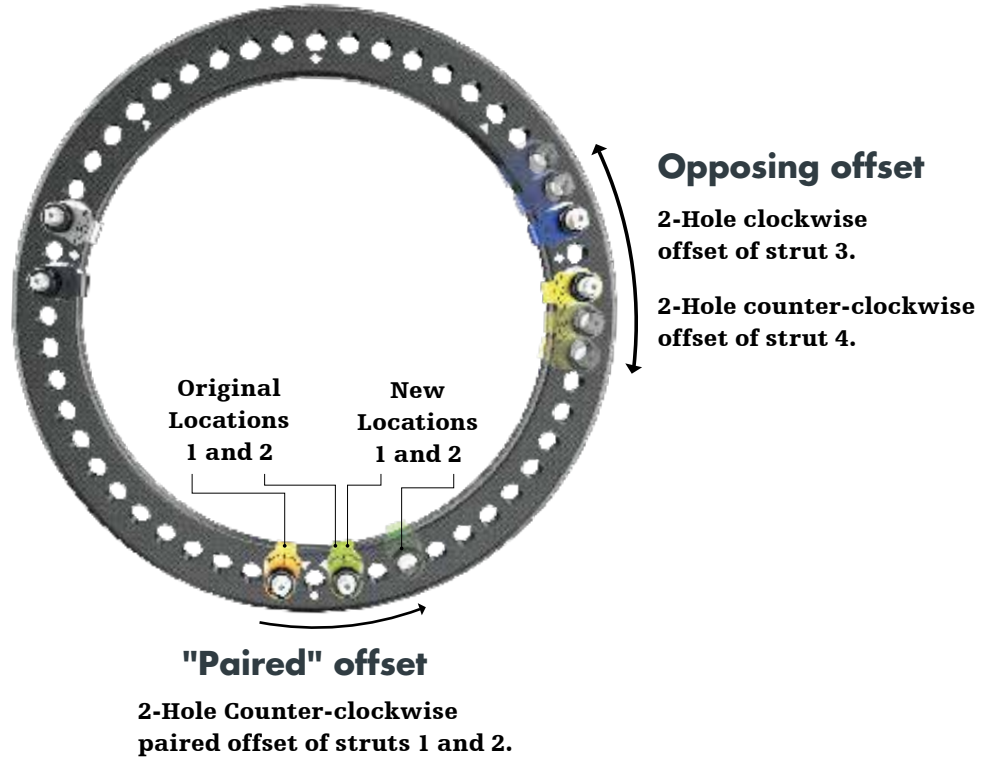

On foot rings, struts can be offset on both the inner and outer rows of holes.

## Strut offsetting

Strut offsetting may also enhance surgical site access as well as radiographic visibility, as struts can be more strategically placed to provide a larger working window.

Strut offsetting may also reduce the need for strut change-outs. When the working length of the strut is consumed, offsetting the attachment site of one or both ends of the strut may help regain strut working length.

The need for hole offsetting may be determined preoperatively with software guidance or be performed intraoperatively as dictated by the surgical scenario and construct design. When using the web application in post-op mode, hole offsets must be factored into the correction plan algorithm.



# Pre-operative planning

The following guidance will provide an example of how the Hoffmann LRF Hexapod can be applied with guidance from the web application's case planning and management tools.

**NOTICE**

The web application will not support 2-level frames in the same case study. Each level must be treated as a separate study with a corresponding correction plan. Please refer to the Hoffmann LRF Hexapod Software Manual (H-IFU-2) for complete instructions on how to use the web application.

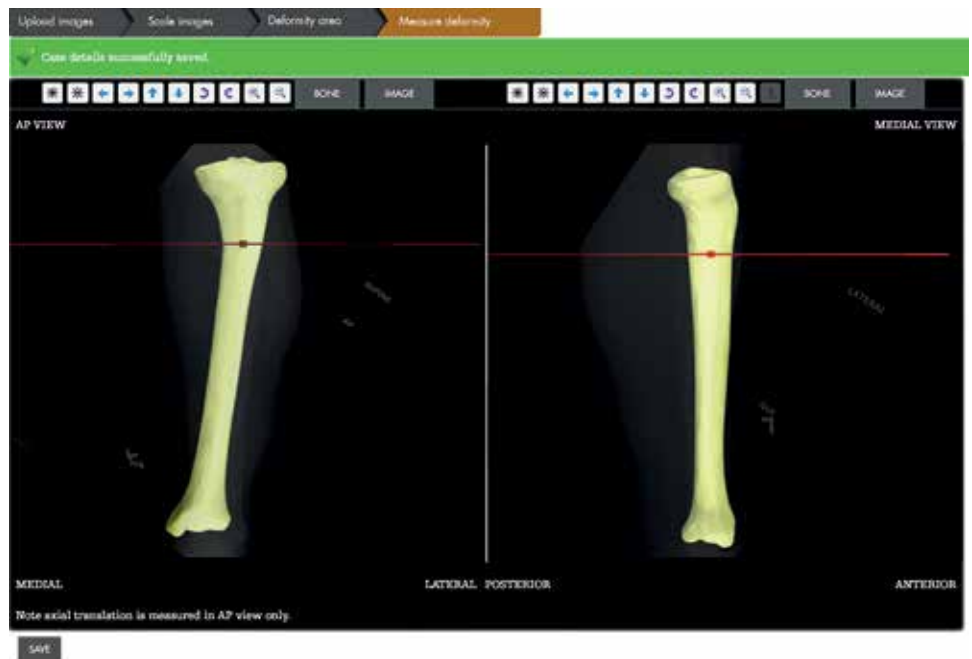

## Step 1: deformity definition

After uploading AP and ML digital X-rays, the digital deformity measurement tool can be used to make a 3D virtual bone representative of the patient's anatomy. If the digital deformity measurement tool is not utilized, the deformity characteristics can be populated and fine-tuned using the slider controls and input boxes.

After selecting either a proximal or distal reference fragment, review the deformity measurements and proposed osteotomy plane. Ensure all inputs are entered accurately.

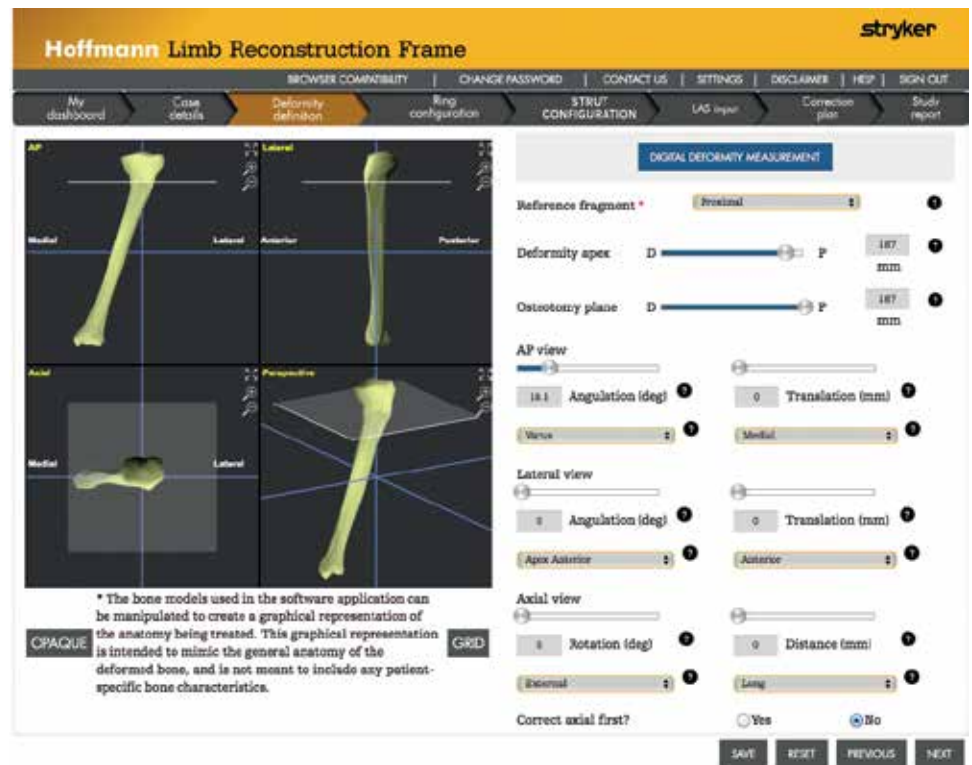

# Pre-operative planning

## Step 2: ring configuration

Plan ring type, material and configuration. Based on the deformity type and severity, the web application can automatically configure rings in an orientation that minimizes correction time ("Calculate" radio button). Alternatively, the user has the ability to manually enter and fine tune all ring placement inputs as desired ("Input All" radio button).

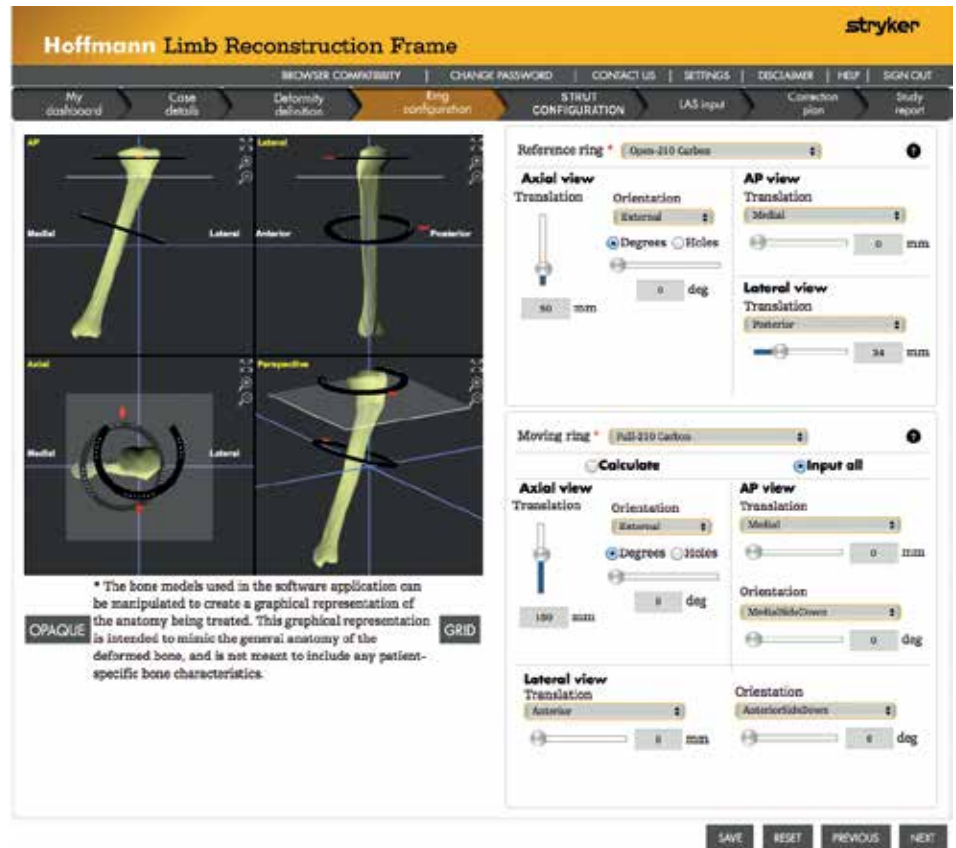

## Step 3: strut configuration

With rings planned, the strut configuration can be determined and used to prepare the construct's initial settings. The software will provide multiple strut configurations with the most correction-efficient option highlighted first. Take note of any planned strut change-out or adjustment details generated by the web application.

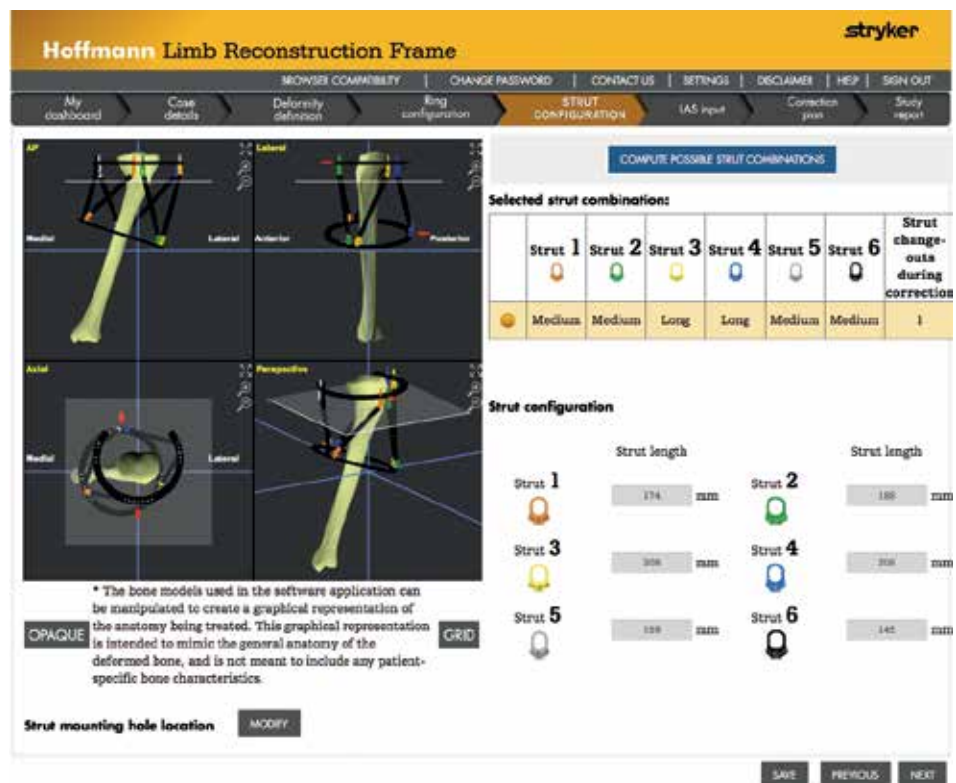

# Pre-operative planning

## Step 4: limiting anatomic structure and correction plan generation

As per the indication, identify any limiting anatomic structures (LAS) and plan the maximum distraction rate (1mm recommended max). This will provide an estimated duration of the correction portion of the treatment.

**NOTICE**

The Limiting Anatomic Structure (LAS) step in the software work flow allows you to define any anatomic structures at risk during the correction. This may be a neurovascular structure, soft tissue envelope, graft, bone end or fracture that may be affected by the correction process.

**CAUTION**

Fast adjustment rates may lead to complications including soft tissue / neurovascular damage. Slower rates of correction may also lead to complications such as premature consolidation. Rates of correction are indication specific and may vary patient-to-patient.

Full details of the correction plan, including initial construct settings and patient adjustment schedule, is derived from user inputs. A bone model animation of the entire correction can be viewed after the correction schedule is produced. This may be useful to understand the construct's dynamics and correction path.

No.	Date	Time	Strut 1 Orange	Strut 2 Green	Strut 3 Yellow	Strut 4 Blue	Strut 5 Gray	Strut 6 Black						
			clicks	mm	clicks	mm	clicks	mm	clicks	mm				
0	Initial position		0	182	0	198.5	0	231.5	0	229.75	0	158	0	145
1	07/13/2016	08:00 AM	0	182	0	198.5	2	231	1	229.5	3	158.75	2	145.5

Correction range	From	To	Strut ID	Old strut ID	New strut ID
6 - 55	07/14/2016 Correction #3	07/31/2016 Correction #1	Strut1	Medium	Loq

Refer to strut change-out schedule to plan upcoming patient visits and required construct components.

## Construct application

Refer to the web application's pre-operative planning guidance to determine construct characteristics. This includes, but is not limited to:

- Ring orientation, size, and type
- Strut orientation, size, and mounting location
- Pre-planned hole offsets
- Anticipated strut adjustments and change-outs

### **CAUTION**

If performing a "rings first" application approach, spacing rings at a minimum ring-to-ring distance of 120mm is recommended.

### **NOTICE**

When the frame is assembled around severe rotational deformities, ensure that struts do not impinge on soft tissues. Larger ring diameters can be considered to increase the clearance between the struts and the soft tissue.

### **CAUTION**

If using a proximal ring block, the distance between stacked rings must be >30mm in order to access the clicking mechanism with the manual adjustment instrument. If mounted closer, the 5mm spanner wrench can be used to actuate the square drive of the strut.

### **NOTICE**

Choice of fixation and placement is dictated by surgeon preference and the specific indications being treated. Patient positioning is dictated by indications and surgeon preference.



# Construct application

## Step 1: mount reference ring

Using a reference wire or pin, the initial location and orientation of the reference ring is established. Be sure to insert the reference wire and attach rings as orthogonal as possible.

### NOTICE

The ring is attached with the master marker  aligned with the anterior surface of the bone.

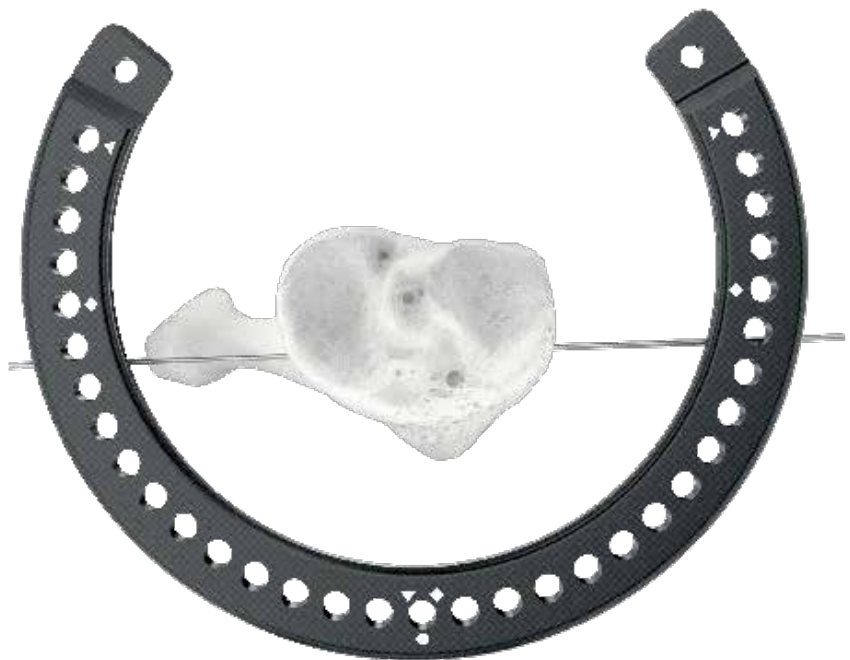

## Construct application

It is recommended that ring size should allow for approximately two finger breadths of space from skin. Shown: open carbon fiber ring to accommodate soft tissue and knee flexion.

When applying fixation, take note of nominal strut attachment sites and avoid placing fixation there if possible.

Once more than one point of fixation is secured to a ring, ring orientation is provisionally fixed. To help avoid fixation component interference when attaching struts, it may be preferred to attach the struts to the ring before applying all points of fixation. Once struts are in place, additional points of fixation can be strategically applied to avoid interference with strut attachment. If needed, hole offsetting can be used to accommodate points of fixation in close proximity to strut attachment sites.

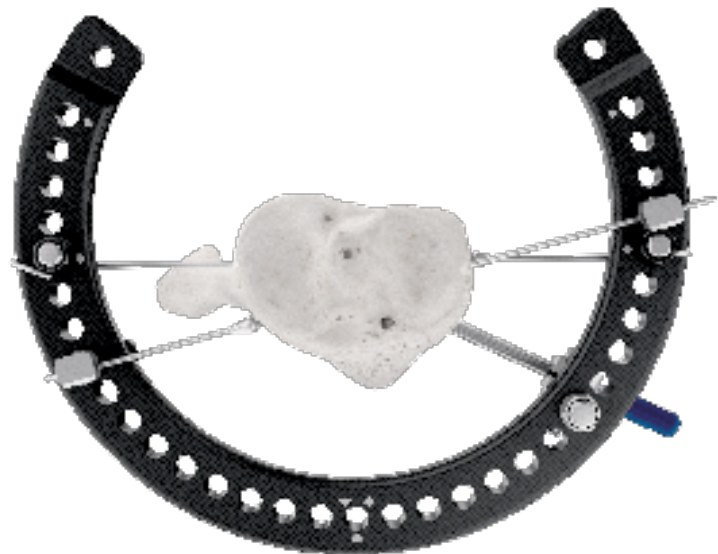

# Construct application

## Step 2: mount moving ring

Before inserting fixation for the moving ring, check that ring spacing can accommodate the minimum strut length in the location where the two rings are closest together. Unless intentionally planning for a non-orthogonal ring placement, the moving ring should be placed orthogonally to the moving fragment.



### CAUTION

The master  marker on the moving ring should be placed directly posterior. If correcting rotation, a rotary offset of the moving ring may be applied before mounting the ring to the bone.

Hydroxyapatite coated apex pins may be preferred in procedures where the frame is on the patient for several months.

HA coated Apex Pins are offered in a range of diameters, lengths and thread lengths.



# Construct application

## Step 3: strut mounting

On the proximal ring, locate the master marker and insert the actuation post of **strut 1** through the hole directly clockwise. If the web application has identified a hole offset position for **strut 1**, insert the strut in this ring hole instead.



### NOTICE

Strut positions are independent of each other and do not shift the nominal mounting position of any of the remaining struts.

### CAUTION

For the web application to perform an accurate calculation, the struts must be mounted directly into the rings within the allowable range of hole offsets. Constructing custom outrigger assemblies to attach struts causes inaccuracies in the software's calculation of the correction plan.

Before securing with a connecting nut (M8), the corresponding **ID clip 1** (orange) can now be seated over the actuation post of the strut such that it rests on the superior ring surface.

Attach the barrel end of **strut 1** to the moving ring using a ring connection bolt. Moving counter-clockwise on the proximal ring, **strut 2** and the corresponding ID clip (green) are mounted in the same fashion.

### CAUTION

To ensure the directional arrows are correctly oriented for the patient, ID clips must be mounted on the square drive end of the strut, typically the proximal ring with the clip lip portion of the ID clip on the inner ring diameter.

# Construct application

## Strut mounting

Repeat this protocol for **struts 3-6**, moving counter-clockwise along the ring and following the triangle markers as a guide.

Confirm that the lengthening scales on each strut are facing outward for easy reference.

### NOTICE

The universal joint integrated into the strut's clicking mechanism is set with a 60° maximum angle to prevent strut attachment at an angle that may be difficult to actuate.

### CAUTION

Once all struts are attached, confirm that struts are correctly identified and securely tightened with counter-torque. Confirm all quick release mechanisms are in the locked position and ensure all colored safety wheels are threaded closed.

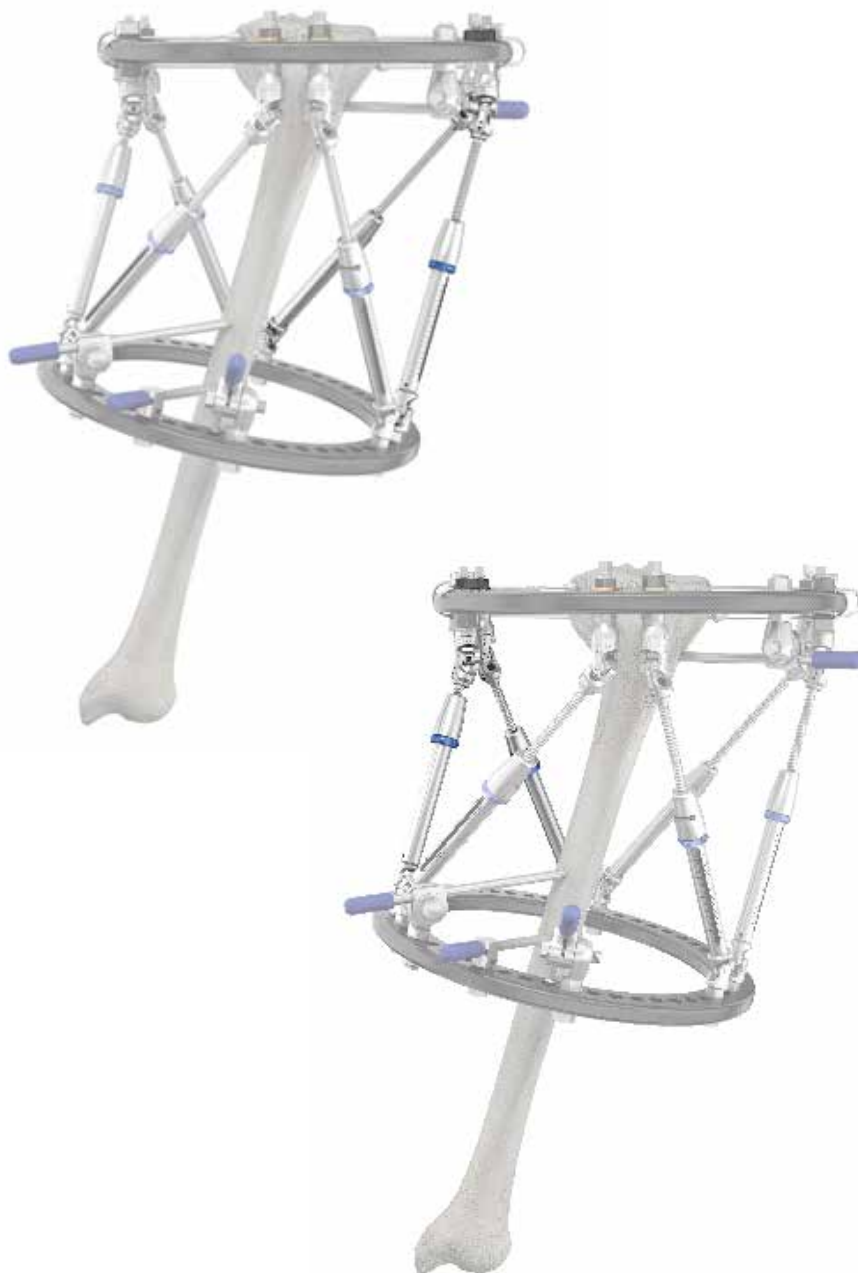

# Construct application

## Construct stability

Assess construct stability and add additional ring levels and points of fixation if necessary.

### **WARNING**

In certain instances, supplemental fixation points should be considered (i.e. obese patients or patients that are ambulatory in the early postoperative phase).

If desired, struts can be positioned to improve physical access and radiographic visibility of the osteotomy. If repositioned, record the new location to be entered into the LRF Web Application postoperatively and ensure the strut is securely retightened.



**Distal frame extension constructed with threaded rods to enhance stability.**

# Construct application

## Step 4: perform corticotomy

After confirming construct stability, a corticotomy can be performed as per surgeon preference, condition of the corticotomy site, and pre-operative software guidance.

Once the corticotomy is verified complete, manual manipulation of the bone segments can now be performed if needed by unlocking one or more struts of the construct. This can be done by loosening the colored safety nuts and unlocking the quick releases.

1/4mm micro adjustments can be made by actuating the strut's clicking mechanism. Counter-clockwise turns distract the strut. Clockwise turns compress.

When satisfied with initial anatomic alignment, lock the quick release mechanisms and tighten the colored safety wheels.



# Construct application

## Finalizing

### **CAUTION**

- Check that all six ID clips are placed around the correct struts and are sequentially ordered moving counter-clockwise around the ring.
- Confirm all nuts and connections are tightened upon completion of the frame. Confirm all quick release mechanisms are in the locked position.

After confirming all component connections are positioned and tightened properly, dress wounds and pin/wire sites.

Record critical software inputs in preparation for post-operative case management and correction plan creation:

- Ring and strut mounting parameters
- Anterior-posterior and lateral-medial X-rays or other imaging as required

The Hoffmann LRF Web Application can now be used in post-op mode to generate the patient's correction plan.



# Strut repositioning and change-out procedure

While executing the patient correction plan, there may be a need to reposition or change-out one or more of the frame's struts once all usable travel is consumed. The time frame for a strut change-out is indicated on the patient's correction plan by the vertically highlighted boxes as well as in the strut change-out summary section of the report.

**CAUTION**  
For accurate execution of the patient correction plan, strut change-outs must occur within the indicated time frame.

When performing a strut repositioning or change-out, the user must preserve the correction that has already been achieved. Before conducting a repositioning or change-out procedure, the patient should be in a seated or resting position without any load applied to the construct.

**CAUTION**  
The construct must be temporarily reinforced with supplemental fixation components to constrain any unwanted motion.

There are a number of methods and components that can be used to temporarily stabilize the construct during a strut change-out procedure.

Strut change schedule											
Correction range		From			To			Strut ID	Old strut ID	New strut ID	
24 - 34		09/18/2016 Correction #4			09/21/2016 Correction #2			Strut3	Long	Medium	

Correction schedule														
No.	Date	Time	Strut 1		Strut 2		Strut 3		Strut 4		Strut 5		Strut 6	
			clicks	mm	clicks	mm	clicks	mm	clicks	mm	clicks	mm	clicks	mm
24		08:00 PM	1	177.75	0	184.25	3	190.5	2	196.75	2	174	3	162
25	09/19/2016	08:00 AM	1	178	1	184	2	190	2	196.25	3	174.75	2	162.5
26		12:00 PM	1	178.25	1	183.75	3	189.25	2	195.75	2	175.25	3	163.25
27		05:00 PM	0	178.25	0	183.75	3	188.5	2	195.25	3	176	3	164
28		08:00 PM	1	178.5	1	183.5	3	187.75	3	194.5	2	176.5	3	164.75
29	09/20/2016	08:00 AM	1	178.75	0	183.5	3	187	2	194	2	177	3	165.5
30		12:00 PM	0	178.75	1	183.25	3	186.25	2	193.5	3	177.75	3	166.25

The example shown utilizes Hoffmann LRF universal components as well as Hoffmann 3 modular fixation components.

### Change Out Components:

- (2) Hoffmann 8mm x 88mm Posts (long)

- (2) M8 Connecting Nuts (used to attached the Hoffmann 8mm Posts to each ring)
- (2) Hoffmann 3 multiplanar Delta Coupling
- (1) 11mm Vectron Rod (350mm Length)
- (2) 7/10 Spanner Wrenches



# Strut repositioning and change-out procedure

## Step 1:

Identify the strut(s) that need to be changed out or adjusted in accordance with the patient's correction plan.



## Step 2:

In close proximity to the identified strut, mount an 8mm post on both the proximal and distal rings with M8 connecting nuts. Use counter-torque to ensure secure connection. Posts can be placed on either the inferior or superior surface of the ring.

### NOTICE

Keeping the posts to one side of the strut will help orient the reinforcement assembly in a position that does not obstruct strut reattachment.



## Strut repositioning and change-out procedure

### Step 3:

Span the proximal and distal posts with the 11mm x 350mm H3 vectron rod and H3 couplings. Detachable thumb wheels can be used for provisional tightening. Remove thumbwheels and completely tighten the clamps to securely fix the supplemental assembly.



### Step 4:

With the construct reinforced, remove or adjust the selected strut. When attaching the new strut, insert the clicking end of the strut first and install the proper ID clip before securing with an M8 connecting nut and counter-torque wrench. Before securing the new strut, first orient the lengthening scale outward for best visibility and then re-secure the barrel end of the strut with the M6 connecting bolt.

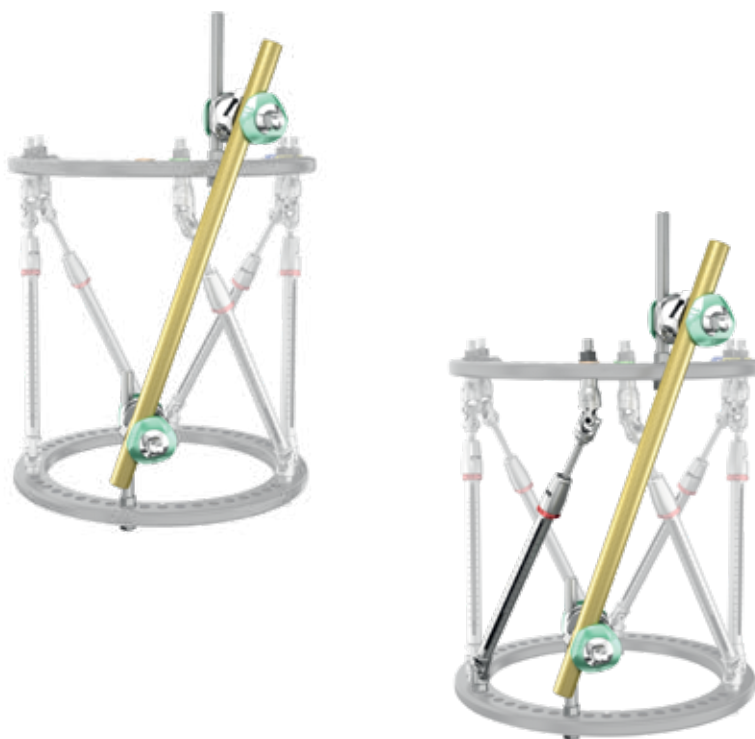

# Strut repositioning and change-out procedure

## Final check

With the new strut in place, review the entire construct to confirm stability. Take the opportunity to confirm all other struts and fixation components are securely tightened.

The patient's correction plan may need to be re-evaluated based on the current bone position and strut settings. If relocating one or more ends of the strut, the patient's correction plan must be updated with the web application and the frame's revised strut type and/or placement parameters.



## Patient adjustments

During the post-op correction phase, the patient will utilize the adjustment instrument to actuate the strut and gradually perform the required deformity correction.

### NOTICE

To compress the length of the strut, the click-lock mechanism is turned clockwise. To distract the strut, the click-lock mechanism is turned counter-clockwise.

Direction of adjustment for each strut is indicated within the patient correction plan. Only make adjustments to the prescribed strut. After a full day of adjustment, the correction should be verified by confirming that the strut's length scale reads the appropriate number on the patient correction plan. Refer to External Fixation Patient Guide (H-PG-1) for detailed instructions for the patient.

### CAUTION

Fast adjustment rates may lead to complications including soft tissue / neurovascular damage. Slower rates of correction may also lead to complications such as premature consolidation. Rates of correction are indication specific and may vary patient-to-patient.

### CAUTION

Do not unintentionally rotate the click-lock mechanism while seating the manual adjustment instrument.

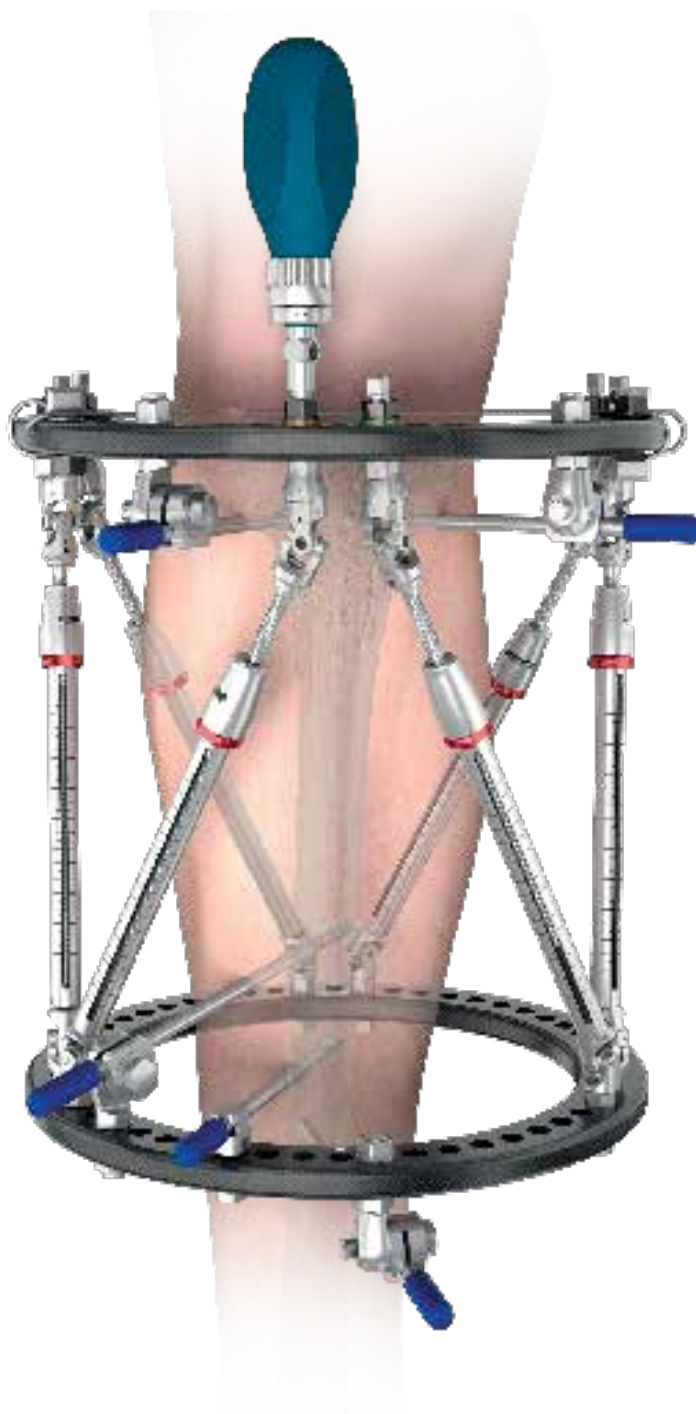

# Construct examples

## Midshaft fracture reduction



**AP View**



**Lateral View**

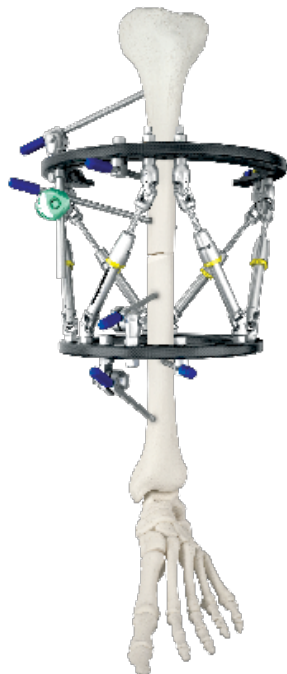

**Corrected AP**

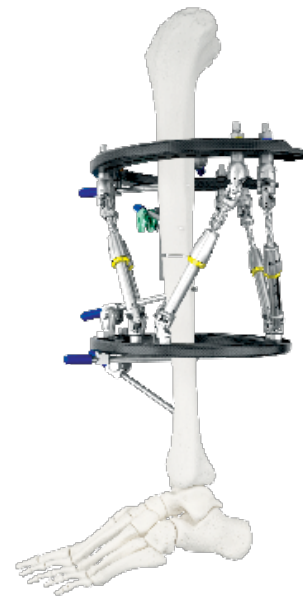

**Corrected Lateral**

# Construct examples

## Equinovarus ankle correction



AP View



Lateral View



Corrected AP



Corrected Lateral

# Construct examples

## Distal femoral valgus correction



**AP View**

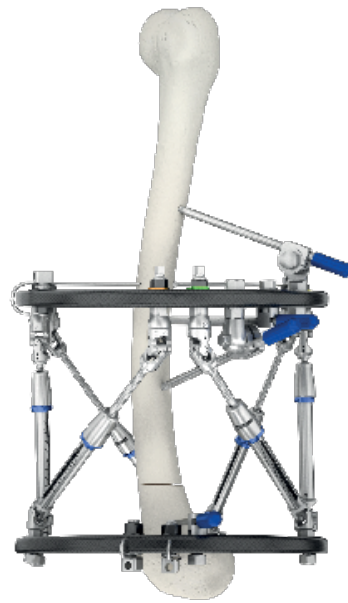

**Lateral View**

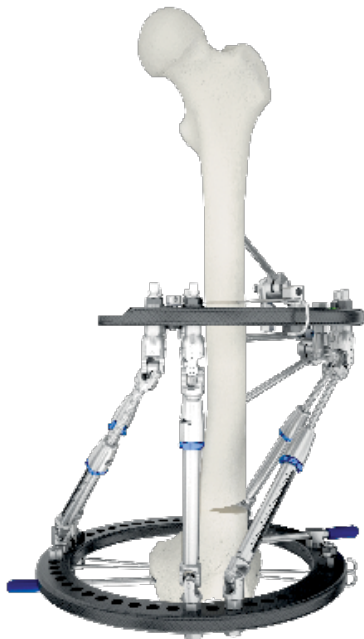

**Corrected AP**



**Corrected Lateral**

# Notes

This document is intended solely for the use of healthcare professionals. A surgeon must always rely on his or her own professional clinical judgment when deciding whether to use a particular product when treating a particular patient. Stryker does not dispense medical advice and recommends that surgeons be trained in the use of any particular product before using it in surgery.

The information presented is intended to demonstrate a Stryker product. A surgeon must always refer to the package insert, product label and/or instructions for use, including the instructions for cleaning and sterilization (if applicable), before using any Stryker product. Products may not be available in all markets because product availability is subject to the regulatory and/or medical practices in individual markets. Please contact your Stryker representative if you have questions about the availability of Stryker products in your area.

The Instructions for Use, Operative Techniques, Cleaning instructions, patient information leaflets and other associated labeling may be requested online at [www.ifu.stryker.com](http://www.ifu.stryker.com) or [www.stryker.com](http://www.stryker.com).

If saving the Instructions for Use, Operative Techniques, Cleaning instructions from the above mentioned websites, please make sure you always have the most up to date version prior to use.

Stryker Corporation or its affiliates own, use, or have applied for the following trademarks or service marks: Apex, Hoffmann, Stryker. All other trademarks are trademarks of their respective owners or holders.

Content ID: **H-ST-34, Rev. 2, 07 - 2020**

Copyright © 2020 Stryker



Manufacturer:  
**Stryker GmbH**  
Bohnackerweg 1  
2545 Selzach, Switzerland  
[www.stryker.com](http://www.stryker.com)