

# AxSOS 3<sup>®</sup>

## Distal Lateral Femur Locking Plate System



**Operative technique**  
ORIF technique

# AxSOS 3

## Distal Lateral Femur Locking Plate System – ORIF technique

### Contents

Introduction . . . . .	3
Indications and contraindications . . . . .	4
Principles of fracture management . . . . .	6
Operative technique . . . . .	7
Step 1 – pre-operative planning . . . . .	7
Step 2 – patient preparation . . . . .	8
Step 3 – aiming block/plate insertion handle assembly . . . . .	9
Step 4 – plate application . . . . .	9
Step 5 – primary plate fixation – distal . . . . .	11
Step 6 – primary plate fixation – proximal. . . . .	12
Step 7 – cortex screw fixation. . . . .	13
Step 8 – cancellous screw fixation . . . . .	13
Step 9 – locking screw fixation . . . . .	14
Step 10 – metaphyseal fixation . . . . .	16
Step 11 – shaft fixation . . . . .	17
Variable angle extension arm. . . . .	18
5.0mm cable plug . . . . .	22
Additional tips . . . . .	25
SPS Titanium – AxSOS 3 Titanium compatibility chart . . . . .	26

This publication sets forth detailed recommended procedures for using Stryker devices and instruments. It offers guidance that you should heed, but, as with any such technical guide, each surgeon must consider the particular needs of each patient and make appropriate adjustments when and as required.

**WARNING**

Follow the instructions provided in our cleaning and sterilization guide (OT-RG-1).

**WARNING**

All non-sterile devices must be cleaned and sterilized before use. Multi-component instruments must be disassembled for cleaning. Please refer to the corresponding assembly/disassembly instructions.

Please remember that the compatibility of different product systems has not been tested unless specified otherwise in the product labeling.

Consult Instructions for Use ([www.ifu.stryker.com](http://www.ifu.stryker.com)) for a complete list of potential adverse effects and adverse events, contraindications, warnings and precautions.

**WARNING**

- The surgeon must advise patients of surgical risks, and make them aware of adverse effects and alternative treatments.
- The patient should be advised that the device cannot and does not replicate a normal healthy bone, that the device can break or become damaged as a result of strenuous activity or trauma and that the device has a finite expected service life.
- Removal or revision of the device may be required sometime in the future due to medical reasons.

# Introduction

The AxSOS 3 Locking Plate System is intended for long bone fracture fixation. The system allows for the use of locking and non-locking screws in the metaphysis and the shaft. This operative technique contains a simple step-by-step procedure for the implantation of the distal lateral femur plate using the ORIF instrumentation. Plates used in this operative technique guide: AxSOS 3 Distal Lateral Femur Plates. Please note that AxSOS 3 is made out of titanium alloy (Ti6Al4V) and is not compatible with any stainless steel plates or screws.

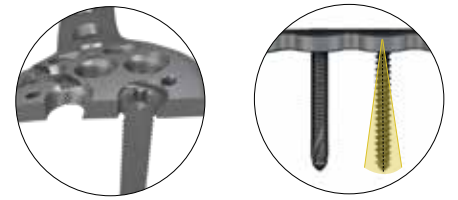

4.5mm cortical screw  
20° cone of angulation

Cancellous Locking Cortical



SPS Titanium Basic Fragment ISO screws used with the AxSOS 3 Large Fragment Plates:

Screws used in this operative technique guide:

## Screw Types

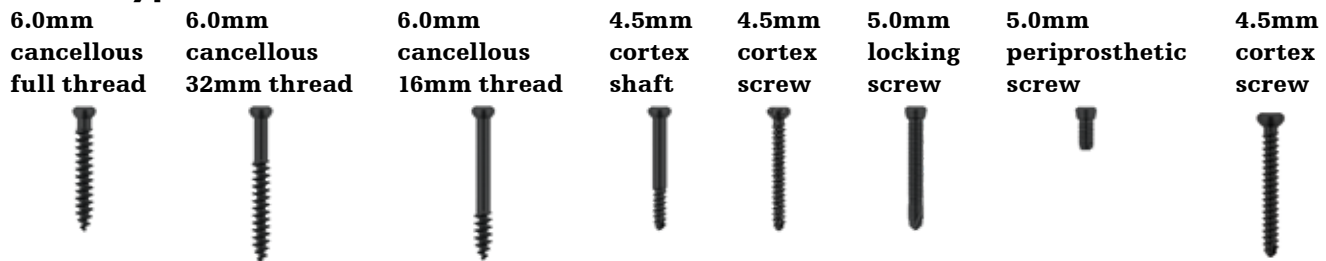

All of the above AxSOS 3 Screws have a T20 screw head interface. Please refer to the compatibility table on page 26 showing SPS and AxSOS 3 compatibility.

All of the above SPS Titanium Basic Fragment ISO screws have a Hex 3.5 screw head interface. Please refer to the compatibility table on page 26 showing SPS and AxSOS 3 Titanium compatibility.

## 5.0mm Blind Screws

These optional inserts may be placed in empty universal screw holes.

5.0mm



## 5.0mm Cable Plug

The 5.0mm Cable Plug helps ensure a stable positioning of a cerclage cable on the plate and helps prevent slipping in oblique cable applications.



## 5.0mm Variable Angle Extension Arm\*

The extension arm allows the variable angle placement of 4.0mm AxSOS 3 Locking Screws next to the plates, thus enabling the surgeon to go around an implant blocking the medullary canal.



\* This product is not CE marked in accordance with applicable EU regulations and directives. Stryker is not marketing or distributing this product in the EU. Any reference to this product is for presentation purposes only.

# Indications and contraindications

## Indications for use

The **AxSOS 3 Distal Lateral Femur Plates** are indicated for diaphyseal, metaphyseal, epiphyseal, extra- and intra-articular fractures; periprosthetic fractures; non-unions; malunions and osteotomies in the distal femur.

The **AxSOS 3 Proximal Lateral Tibia and Proximal Medial Tibia Plates** are indicated for diaphyseal, metaphyseal, epiphyseal, extra- and intra-articular fractures; periprosthetic fractures; non-unions; malunions and osteotomies in the proximal tibia.

The **AxSOS 3 Distal Anterolateral Tibia and Distal Medial Tibia Plates** are indicated for diaphyseal, metaphyseal, epiphyseal, extra- and intra-articular fractures; non-unions; malunions and osteotomies in the distal tibia.

The **AxSOS 3 Proximal Lateral Humerus Plates** are indicated for diaphyseal, metaphyseal, epiphyseal, extra- and intra-articular fractures; non-unions; malunions and osteotomies in the proximal humerus.

The **AxSOS 3 Waisted Compression Plates** are indicated for:

- diaphyseal, metaphyseal, epiphyseal, extra- and intra-articular fractures; periprosthetic fractures; non-unions; malunions and osteotomies in long bones of the upper and lower extremities,
- fracture fixation of diaphyseal and metaphyseal areas of long bones in pediatric patients, and
- fixation of the scapula and the pelvis (4mm Waisted Compression Plate only).

The AxSOS 3 System is indicated for use in normal and osteopenic bone.

## MRI Safety Information

### **AxSOS 3 System (no periprosthetic indication).**

#### CAUTION

Non-clinical testing has demonstrated the Stryker AxSOS 3 System is MR Conditional.

A patient with these devices can be safely scanned in an MR system meeting the following conditions:

- Static magnetic field of 1.5T and 3.0T
- Maximum spatial field gradient of 3000 gauss/cm (30T/m)
- Maximum MR system reported, whole body averaged specific absorption rate (SAR) of 2 W/kg (Normal Operating Mode)

Under the scan conditions defined above, the Stryker AxSOS 3 System is expected to produce a maximum temperature rise of less than 7.1°C after 15 minutes of continuous scanning.

In non-clinical testing, the image artifact caused by the device extends approximately 32mm from the Stryker AxSOS 3 System when imaged with a gradient echo pulse sequence and a 3.0T MRI system.

### **AxSOS 3 System (periprosthetic indication of the femur)**

#### CAUTION

Non-clinical testing has demonstrated the Stryker AxSOS 3 System is MR conditional.

A patient with these devices can be safely scanned in an MR system meeting the following conditions:

- Static magnetic field of 1.5T and 3.0T
- Maximum spatial field gradient of 2000 gauss/cm (20T/m)
- Maximum MR system reported, whole body averaged specific absorption rate (SAR) of 2 W/kg (Normal Operating Mode)
- Scan time restriction: maximum 6 minutes of continuous scanning
- Only in combination with MR conditional Stryker hip implants

# Indications and contraindications

Stryker AxSOS 3 System is expected to produce a maximum temperature rise of less than 8.9°C after 6 minutes of continuous scanning.

In non-clinical testing, the image artifact caused by the device extends approximately 45mm from the Stryker AxSOS 3 System when imaged with a gradient echo pulse sequence and a 3.0T MRI system.

## CAUTION

The MRI safety information provided is based on testing which did not include supplementary devices. If there are supplementary devices (i.e. plates, screws, wires, prosthesis etc.) present in proximity to the system, this could result in additional MRI effects and the information provided above may not apply.

## Contraindications

The physician's education, training and professional judgement must be relied upon to choose the most appropriate device and treatment.

Conditions presenting an increased risk of failure include:

- Any active or suspected latent infection or marked local inflammation in or about the affected area
- Compromised vascularity that would inhibit adequate blood supply to the fracture or the operative site
- Bone stock compromised by disease, infection or prior implantation that cannot provide adequate support and / or fixation of the devices
- Material sensitivity, documented or suspected
- Patients having inadequate tissue coverage over the operative site
- Implant utilization that would interfere with anatomical structures or physiological performance

- Any mental or neuromuscular disorder which would create an unacceptable risk of fixation failure or complications in postoperative care
- Other medical or surgical conditions which would preclude the potential benefit of surgery

Detailed information is included in the instructions for use ([www.ifu.stryker.com](http://www.ifu.stryker.com)).

See instruction for use for a complete list of potential adverse effects and contraindications. The surgeon must discuss all relevant risks, including the finite lifetime of the device with the patient.

## CAUTION

The AxSOS 3 4.0mm and 5.0mm Waisted Compression Plates should not cross the growth plates of pediatric patients.

## NOTICE

The only plates indicated for pediatric use are the 4.0mm and 5.0mm Waisted Compression Plates.

# Principles of fracture management

Following the OTA/AO principles of fracture management<sup>1</sup> the AxSOS 3 Compression Plates and associated implants of the AxSOS 3 system are utilized to reconstruct the anatomy and restore its function:

1. Fracture reduction to restore anatomical relationships.
2. Fracture fixation providing absolute or relative stability as the “personality” of fracture, patient and injury requires.
3. Preservation of blood supply to soft tissues and bone.
4. Early and safe mobilization of the injured part and the patient as a whole.

For long bone fracture fixation as well as diaphyseal and metaphyseal areas in pediatric patients and also for scapula and the pelvis the following steps are performed to achieve fracture fixation providing absolute or relative stability:

1. Diagnosis, identification of the indication and severity of fracture.
2. Prepare operation (pre-operative planning).
3. Approach (incision, access to fractured area).
4. Fracture reduction.
5. Plate selection – size (width, length), type and selection of screw configuration.
6. Contouring of the plate (if necessary).
7. Fixation (according to the different techniques described: compression, neutralization, and bridge plating).
8. Aftercare / post-operative treatment.

<sup>1</sup>AO Principles of Fracture Management Thomas Rüedi , Richard E. Buckley, Christopher G. Moran Vol. 1: Principles, Vol. 2: Specific fractures

# Operative technique

## Step 1 – pre-operative planning

Use of the X-ray template (ref 981204) or E-template in association with fluoroscopy can assist in the selection of an appropriately sized implant.

**NOTICE**

For conventional templates the scale is 1:1.15 which usually matches with analogous X-rays. If digital X-ray images are used correct magnification has to be verified prior to use (fig. 1).

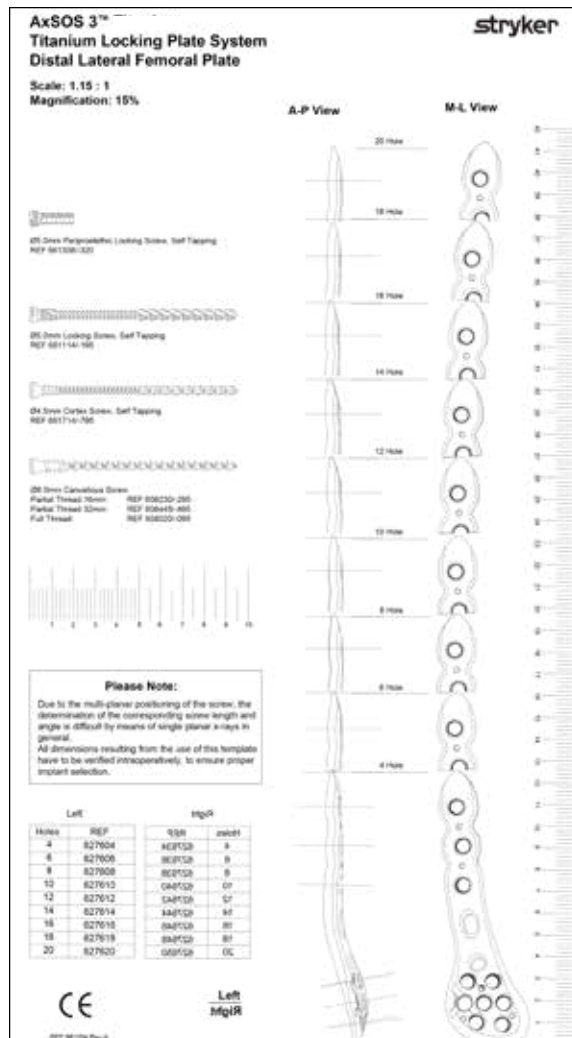

Fig. 1

# Operative technique

## Step 2 – patient preparation

### Patient positioning

Supine with option to flex the knee up to 60° over a leg support. Visualisation of the distal femur under fluoroscopy in both the lateral and AP views is necessary.

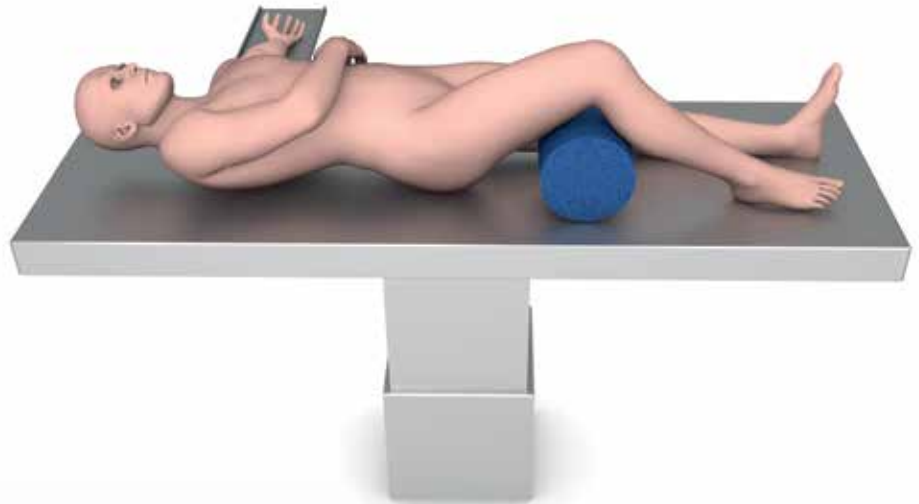

### Surgical approach

Standard lateral, modified lateral or lateral parapatellar approach.

### Reduction

Anatomical reduction of the fracture should be performed either by direct visualization with the help of percutaneous clamps, or alternatively a bridging external fixator to aid with indirect reduction to correct the length, rotation, recurvatum and varus-valgus.

Fracture reduction of the articular surface should then be checked by fluoroscopy or direct visualisation. Use K-wires as necessary to temporarily secure the reduction.

Typically, K-wires set parallel to the joint axis will not only act to hold and support the reduction, but also help to visualize/ identify the joint. Care must be taken that these do not interfere with the required plate and screw positions.

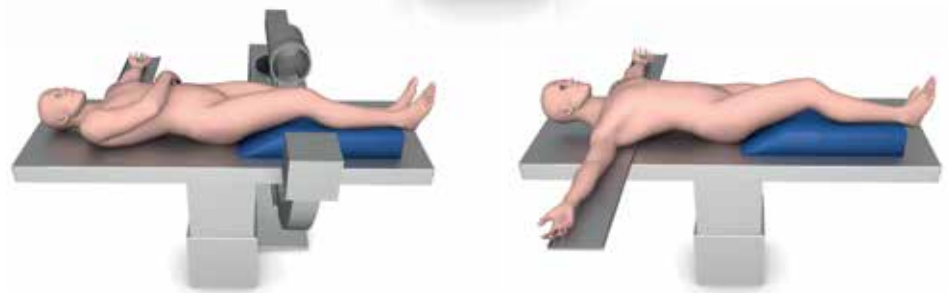

#### CAUTION

Consideration must also be taken when positioning independent lag screws prior to plate placement to ensure that they do not interfere with the planned plate location screw trajectories.

If any large bony defects are present they should be filled by either bone graft or bone substitute material.

#### NOTICE

Distal femur plates of the AxSOS 3 System can be inserted in a minimally invasive technique with targeting instrumentation. For detailed information please refer to the specific targeting operative technique available from your Stryker representative.

# Operative technique

## Step 3 – aiming block /plate insertion handle assembly

In order to help facilitate drill sleeve insertion as well as plate handle attachment to the plate, the aiming block may be used.

Attach the appropriate aiming block (right ref 705067 / left ref 705068) to the plate by hand. If desired, the handle for plate insertion (ref 702778) can now be attached to help facilitate plate positioning and sliding of longer plates sub-muscularly (fig. 2-5).

## Step 4 – plate application

Depending on the fracture pattern the surgical exposure is performed (lateral / anterolateral / lateral para-patellar as described above). Fracture reduction, once obtained, can be held provisionally with K-wires 2.0mm x 150mm (ref 390192) or K-wires 2.0mm x 234mm (ref 705002) and /or reduction forceps. External fixation may also be utilized to help with axial, angular, and rotational control across the fracture. Confirm anatomic reduction of the articular surface via direct visualization, palpation, and /or fluoroscopy.\*

## Bending

In most cases, anatomically pre-contoured plates will fit without the need for further bending. However, should additional bending of the plate be required the table plate bender (ref 702900) should be used.



Fig. 2



Fig. 3



Fig. 4



Fig. 5

## ⚠ CAUTION

Bending of the plate in the region of the universal holes may affect the ability to correctly seat the locking screws into the plate and is therefore not permitted. Do not over-bend the plate or bend back and forth as this may weaken the plate.

\* Skeletal trauma, 2nd ed., Master techniques in orthopaedic surgery.

# Operative technique

## Plate positioning

Position the plate on the lateral surface of the femur by using the handle for plate insertion (ref 702778) to slide the plate proximally in a sub-muscular fashion. As you insert the plate, use the plate to feel the femur to confirm a direct lateral position, not anterior or posterior to the femoral shaft.

### NOTICE

Avoid plate insertion through the muscle to avoid intra-muscular vessel disruption. Avoid periosteal disruption while inserting the plate to help preserve bone blood supply.

Prior to any screw fixation, confirm that plate placement is correct.

Confirm that the capsule edges and iliotibial band are not trapped under the plate, as these layers will need to be available for layered wound closure.

Confirm that the plate is sub-muscular, not intra-muscular.

The plate is in the proper position when the distal and anterior margin of the plate is approximately 5mm – 10mm from the articular surface (fig. 7).

Depending on the position and angulation of the image intensifier relative to the plate vs. the bone the correct placement of the plate can vary on the picture on the screen.

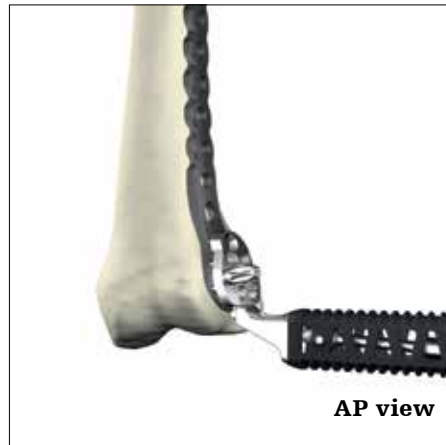

Fig. 6

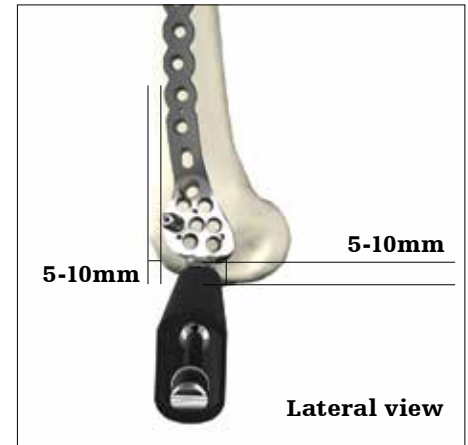
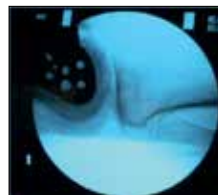
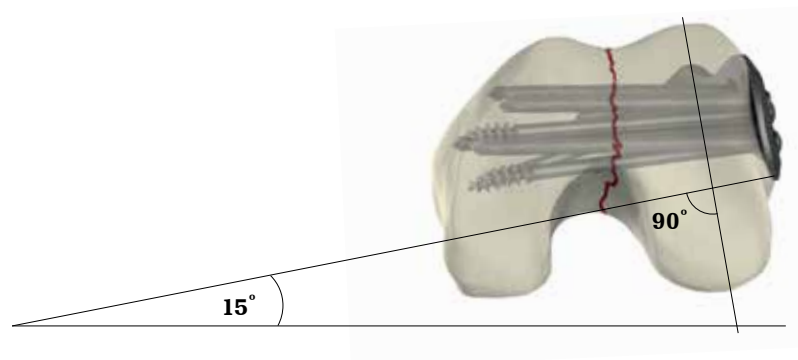
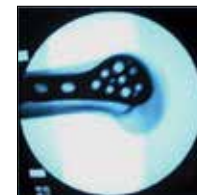

Fig. 7



True medial-lateral on plate: 15° rotation of fluoroscopy unit shows the true plate placement on the condyle.



True medial-lateral on bone: plate shows too anterior, although the plate position is correct.

Fig. 8

It is recommended to check with a true medial-lateral on plate for the 5mm–10mm approximate distance from the joint surface (fig. 7–8).

This helps to ensure that the most distal locking screws are directly supporting the joint surface.

# Operative technique

## Step 5 – primary plate fixation – distal

The K-wire holes in the metaphyseal part of the plate allow for temporary plate fixation to the articular block. (Fig. 9).

Using the K-wire sleeve (ref 705041) in conjunction with the drill sleeve (ref 705076 or ref 705042), a 2.0mm x 234mm K-wire (ref 705002) can now be inserted into one of the distal locking screw holes (fig. 10). This step shows the position of the locking screw in relation to the joint and the intercondylar notch, and confirms the screw will not be placed intra-articularly.

This wire should be parallel to the joint line to assure proper alignment of the distal femur. Using fluoroscopy, the position of this K-wire can be checked to ensure correct plate positioning. Correct proximal placement should also be re-confirmed at this point to make sure the plate shaft is properly aligned over the lateral surface of the femoral shaft (fig. 11).

If the distal and axial alignment of the plate cannot be achieved, the K-wire should be removed, the plate readjusted, and the above procedure repeated until both the K-wire and the plate are in the desired position.

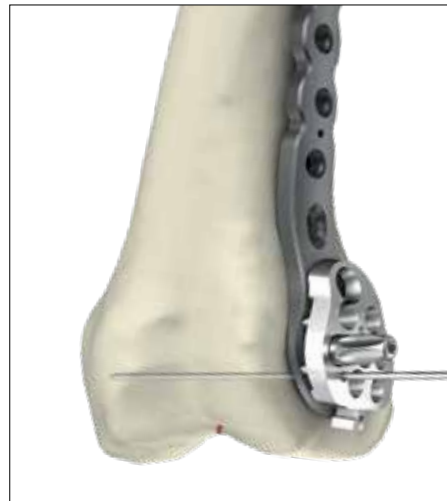

Fig. 9

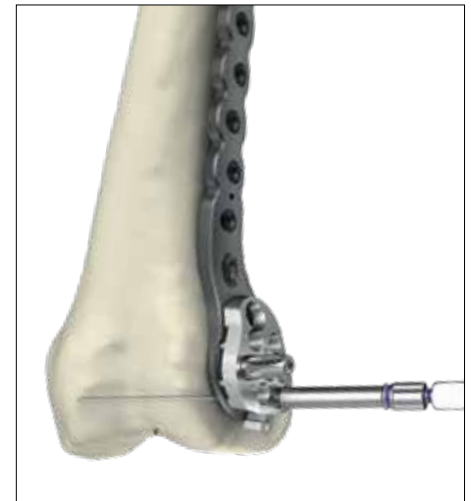

Fig. 10

Additional 2.0mm x 234mm K-wires (ref 705002) can be inserted in the K-wire holes around the universal holes to further help secure the plate to the bone and also support depressed areas in fragments of the articular surface.

Do not remove the drill sleeve and K-wire sleeve at this point as it will cause a loss of the plate position or reduction.

Remove the handle for plate insertion (ref 702778) by pushing the metal lever on top of the handle sideways.



Fig. 11

# Operative technique

## Step 6 – primary plate fixation – proximal

The proximal end of the plate can now be secured. This can be achieved through one of four methods:

- A K-wire inserted in a K-wire hole
- A 4.5mm cortex screw is inserted in a universal hole using the standard technique
- A K-wire can be inserted in a universal hole through the K-wire/drill sleeve assembly
- The temporary plate fixator (ref 705019) is inserted in a universal hole

In addition to providing temporary fixation, the temporary plate fixator pushes the plate to the bone. Also, it has a self-drilling, self-tapping tip for quick insertion into cortical bone (fig. 11).

In order to protect surrounding soft tissues during pin insertion, the temporary plate fixator sleeve must be pre-assembled onto the temporary plate fixator pin with the self-drilling tip of the pin being flush with the tip of the sleeve (fig. 12).

**CAUTION**

The insertion of the temporary plate fixator pin must be done through the sleeve to help prevent tissue damage, especially when used in a MIPO approach.

To help prevent thermal necrosis during the drilling stage, it is recommended that the temporary plate fixator pin is inserted by hand.

Once the device is inserted through the far cortex, the threaded outer sleeve is turned clockwise until the plate is in contact with the bone (fig. 13–15).

Replacing the temporary plate fixator with locking or non-locking screws for definitive fixation is not recommended as proper alignment of the temporary plate fixator pin may not be guaranteed.

If placing a screw should be required for final fixation, pre-drilling the hole using the appropriate drill guide as described by the following cortex, cancellous, and locking screw fixation guidelines is required.



Fig. 12

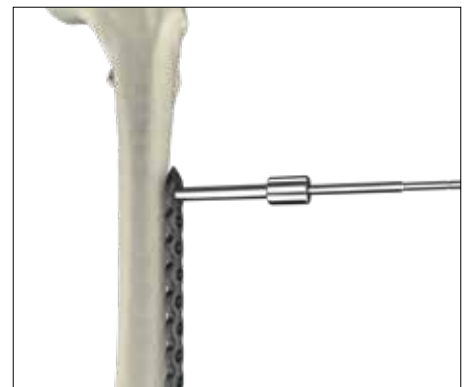

Fig. 13



Fig. 14

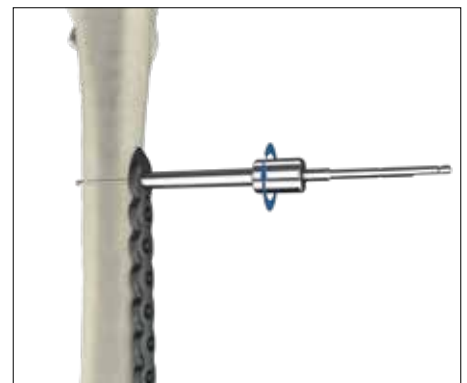

Fig. 15

# Operative technique

## Step 7 – cortex screw fixation

Take the drill guide for non-locking screws (ref 705036) together with the Ø3.2mm drill bit (ref 705032) and drill through both cortices for bi-cortical screw fixation (fig. 16).

The correct screw length can be determined by using the blue depth gauge (ref 705014) or by reading off of the drill. See page 14 for details.

To set the screw in a lag function, over-drill the first cortex using the cortical opener Ø4.5mm (ref 700354) and the Ø4.5mm corresponding end of the double drill guide (ref 705037). Then insert the opposite Ø3.2mm end of the double drill guide into the pre-drilled hole. Drill through the second cortex using the Ø3.2mm drill bit (ref 705032).

The appropriate cortex screw is inserted using the T20 screwdriver (ref 705021) or the screwdriver bit (ref 705020). In hard cortical bone, it is advised to use the cortical tap Ø4.5mm (ref 702806) before screw insertion.

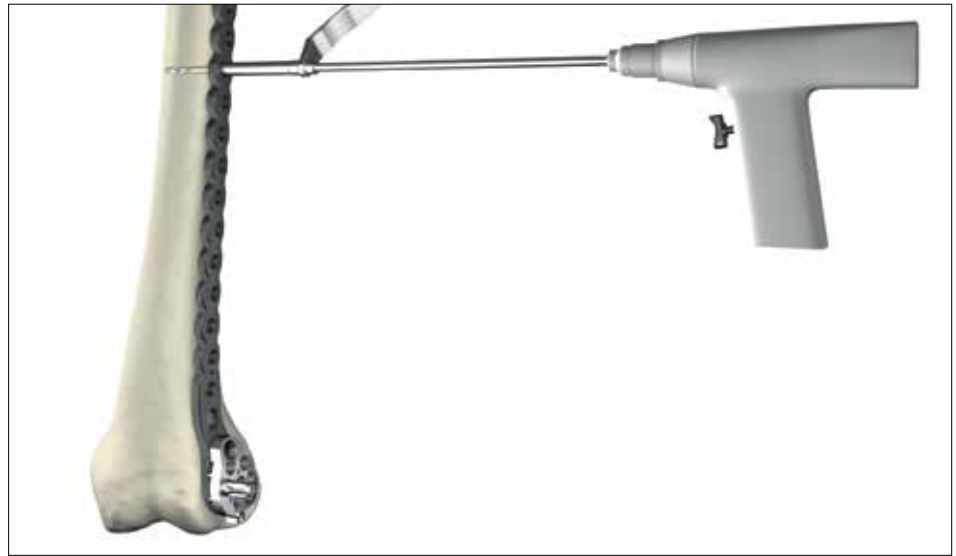

Fig. 16



## Step 8 – cancellous screw fixation

Take the drill guide for non-locking screws (ref 705036) together with the Ø3.2mm drill bit (ref 705032) and drill through both cortices in case bi-cortical screw fixation is performed.

To set the partially threaded cancellous screw in a lag function, over-drill the first cortex using the cortical opener Ø4.5mm (ref 705006) and the Ø4.5mm corresponding end of the double drill guide (ref 705037).

Then insert the opposite Ø3.2mm end of the double drill guide into the pre-drilled hole. Drill through the second cortex using the Ø3.2mm drill bit (ref 705032). The appropriate Ø6.0mm cancellous screw is inserted using the T20 screwdriver (ref 705021) or the screwdriver bit (ref 705020) for power insertion.

In hard cortical bone, it is advised to use the cancellous tap Ø6.0mm (ref 705054) before screw insertion.

Ref	Description	
705036	Drill guide for non-locking screws Ø3.2mm	
705037	Double drill guide Ø4.5mm / Ø3.2mm	

# Operative technique

## Correct screw selection

Appropriate screw length selection is important for the stability of the fixation. Measurements follow the principle of “what you read is what you get”. This means that the measured value in millimeters on the blue depth gauge or the drill bit is the exact value of the screw to be selected.

**⚠ CAUTION**

If (self-tapping) screws are intended to be positioned bi-cortically make sure the tip is slightly sticking out on the far cortex. Add 2mm–3mm to measured length for optimal bi-cortical shaft fixation.

## Step 9 – locking screw fixation

Always lag before you lock. The plate fixation should always begin with non-locking screws prior to the placement of any locking screws.

Use the drill sleeve (ref 705042 short, ref 705076 medium) together with a 4.3mm drill bit (ref 705043 short, ref 705078 medium) to pre-drill the core hole for subsequent locking screw placement.

Medium size sleeves and drill bits show 2 blue color lines, short sleeves and drill bits show 1 line. Blue represents the color code for the 5.0mm locking system. All instruments with a blue color ring are to be used for preparation of monoaxial locking screw placement.

The locking screw length can then be measured using one of the two options illustrated below (fig. 17, 18).

**⚠ CAUTION**

When using the “read off drill bit calibration” measurement option, always make sure to use the drill and sleeve with the corresponding number of color rings (fig. 18).

It is recommended to use multiple fluoroscopic views to ensure proper location and depth of the drill when reading off the drill bit calibration.

## Measurement options

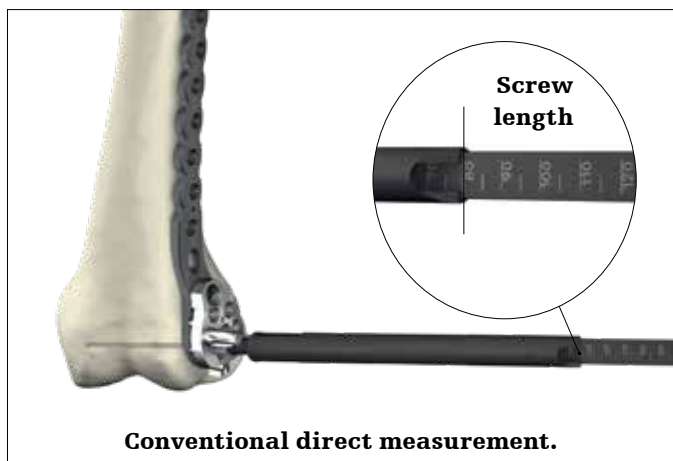

Fig. 17

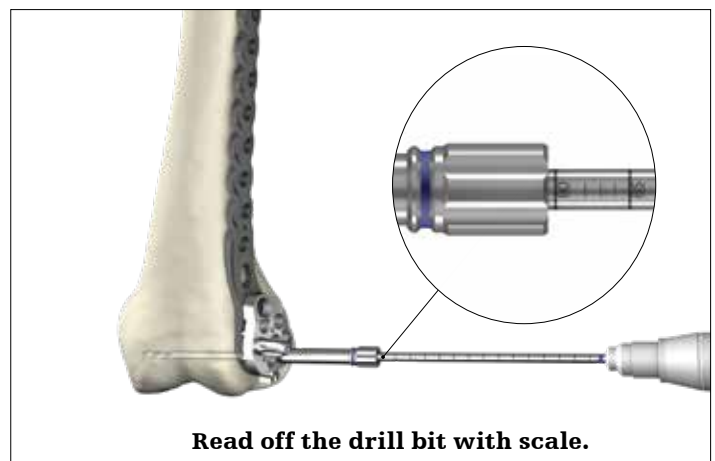

Fig. 18

## Operative technique

The appropriately sized locking screw is then inserted using either the screwdriver T20 (ref 705021) (fig. 19) or the screwdriver bit T20 (ref 705020) with a selected handle (teardrop handle small (ref 702429) or the T-handle (ref 702430)).

### ⚠ CAUTION

If inserting locking screws under power, make sure to use a low speed drill setting to avoid potential thermal necrosis.

### ⚠ CAUTION

Always perform final tightening by hand using the torque limiter (ref 702750) in combination with a screwdriver bit T20 (ref 705020) and T-handle (ref 702430) (fig. 20, 21).

This helps to prevent over-tightening of locking screws, and also helps ensure that these screws are tightened to a torque of 4Nm. The device will click when the torque reaches 4Nm.

### ⚠ CAUTION

Ensure that the screwdriver tip is fully seated in the screw head, and do not angulate the screwdriver. In the extreme event of broken or stripped screws, the Stryker implant extraction set (Content ID IES-ST-1) includes a variety of removal instruments for broken screws.



Fig. 19

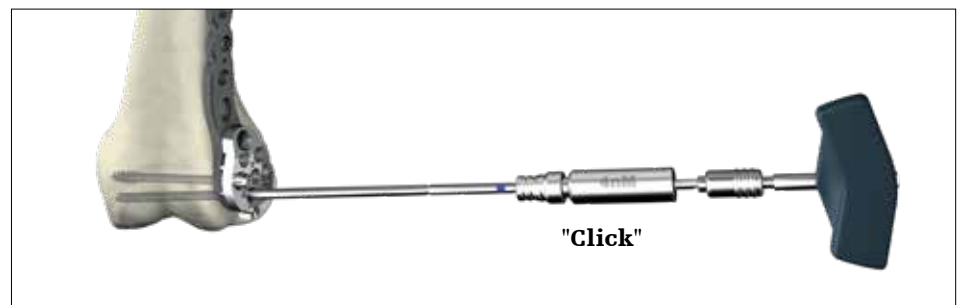

Fig. 20



Fig. 21

### ⚠ CAUTION

The torque limiters require routine maintenance. Consult instructions for use at [ifu.stryker.com](http://ifu.stryker.com).

# Operative technique

## Step 10 – metaphyseal fixation

Locking screws cannot act as lag screws. Should an interfragmentary compression effect be required in cases of intracondylar splits, non-locking screws must be placed prior to the placement of any locking screws.

Consideration must be taken when positioning non-locking screws to ensure that they do not interfere with the given locking screw trajectories (fig. 23, 24). Those trajectories may be visualized using K-wires (ref 705002) inserted through a K-wire/locking drill sleeve assembly (ref 705041 in ref 705042) (fig. 23).

### NOTICE

The targeter attachment hole (A) and the metaphyseal non-locking hole (B) do not allow locking screw fixation. They accept non-locking screws only (fig. 22).

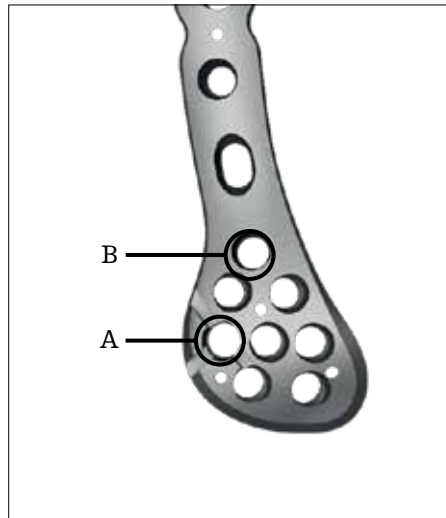

Fig. 22



Fig. 23

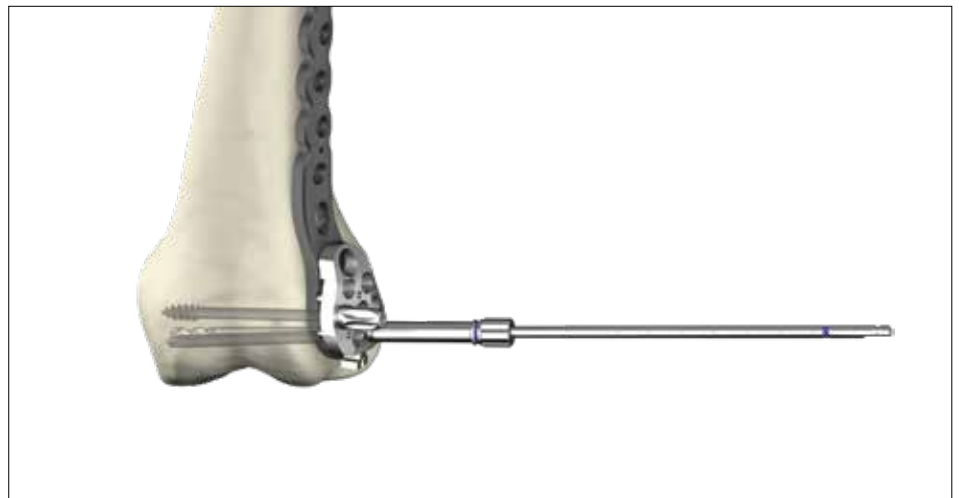

Fig. 24

# Operative technique

## Step 11 – shaft fixation

The universal shaft holes of the AxSOS 3 Distal Lateral Femur Plates have been designed to accept either Ø4.5mm cortex, Ø6.0mm cancellous or Ø5.0mm locking screws (fig. 25). Detailed instructions are described in the cortex, cancellous, and locking screw fixation sections.

### ⚠ CAUTION

If a combination of non-locking and locking screws are used in the shaft, the plate fixation should begin with non-locking screws prior to the placement of any locking screws. Always lag before you lock.

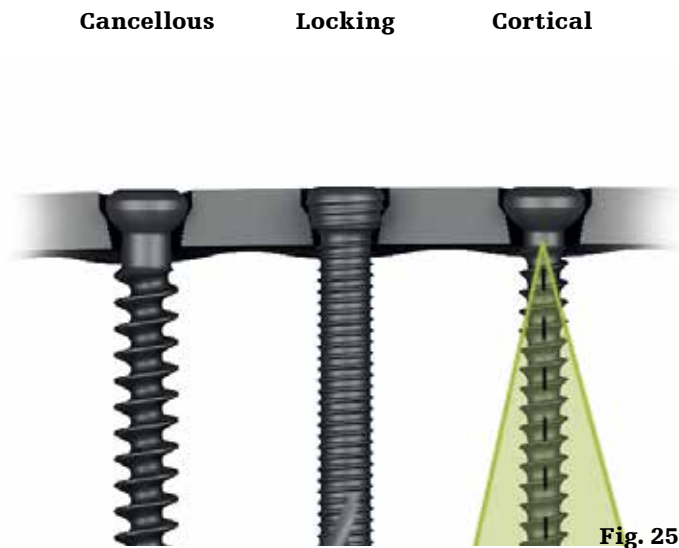

Final plate and screw positions are shown in figures 26–28.



Fig. 26



Fig. 27



Fig. 28

## 5.0mm Variable Angle Extension Arm\*

The 5.0mm variable angle extension arm\* (ref 991088S, referred to as extension arm), made out of Titanium/CoCr, can be inserted into 5.0mm universal holes of the broad or narrow AxSOS 3 Compression plates or in the universal holes of the diaphyseal area of the AxSOS 3 Distal Lateral Femur Plates. The extension arm allows the variable angle placement of 4.0mm AxSOS 3 Locking Screws next to the plates, thus enabling the surgeon to go around an implant blocking the medullary canal.

To insert an extension arm follow the next steps. The extension arm can be placed manually or optionally with the orange 4.0mm drill sleeve as placement aid. In this case fix and tighten the orange 4.0mm drill sleeve by hand in the polyaxial mechanism (fig. 29).



Fig. 29



**NOTICE**

Hole number 17 in long AxSOS 3 Distal Lateral Femur Plates is designed slightly in an oblique way to avoid conflicting protection sleeves with the optional targeting instrumentation. Hole number 17 cannot be used together with the extension arm – see picture on the right. The universal holes in the metaphyseal part of Distal Lateral Femur Plates and hole number one (oblong, non-locking) can't be used together with an extension arm.



Fig. 30

**T15 screwdriver bit 705015    2.5Nm torque limiter 702760    T-handle 702427**

Insert the 4.0mm blind screw (packaged together with the extension arm) using the T15 screwdriver from the 4.0mm AxSOS 3 Titanium System (fig. 30).

\* This product is not CE marked in accordance with applicable EU regulations and directives. Stryker is not marketing or distributing this product in the EU. Any reference to this product is for presentation purposes only.

## 5.0mm Variable Angle Extension Arm

While tightening the 4.0mm blind screw adjust the rotation of the extension arm and hold it in place if necessary. Final tighten with the 2.5Nm torque limiter. At least one click shall be emitted (fig. 31).



**Fig. 31**

Use the drill sleeve in the polyaxial hole and choose the desired angle for the screw placement. The cone allows for a +/- 15 degree cone of angulation (fig. 32).

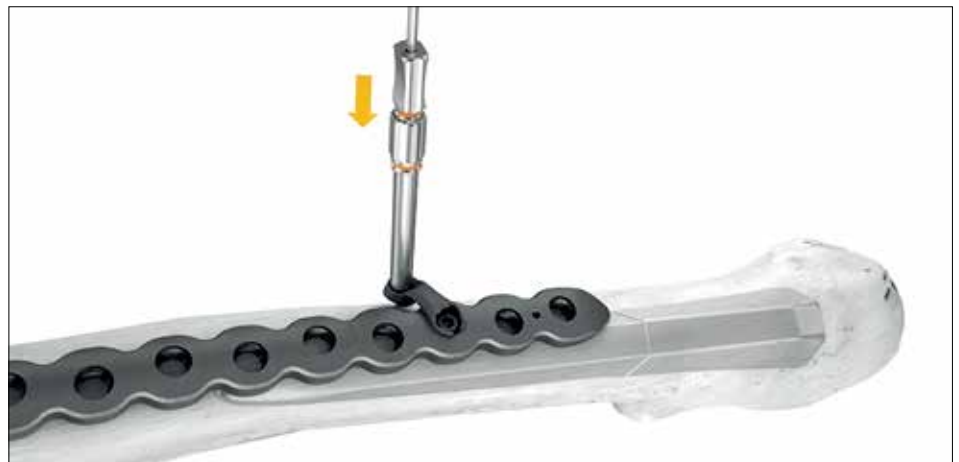

**Fig. 32**

In the event of placing a K-wire use it together with the K-wire sleeve (fig. 33). Tighten the drill sleeve by hand.

### NOTICE

Be aware of the different diameter and flexibility between K-wire, drill bit and 4.0mm locking screws.



**Fig. 33**

## 5.0mm Variable Angle Extension Arm

Remove the K-wire and the K-wire sleeve and drill with the 3.1mm drill bit (fig. 34). Measure by reading off the drill bit. Alternatively remove the drill sleeve and measure with the depth gauge. Place an appropriate 4mm locking screw.



Fig. 34

Insert and final tighten the 4mm locking screw with the 2.5Nm torque limiter. At least one click shall be emitted (fig. 35).

**CAUTION**

In case of mixing non-locking and locking screws always follow the principle of "lag before lock".



Fig. 35

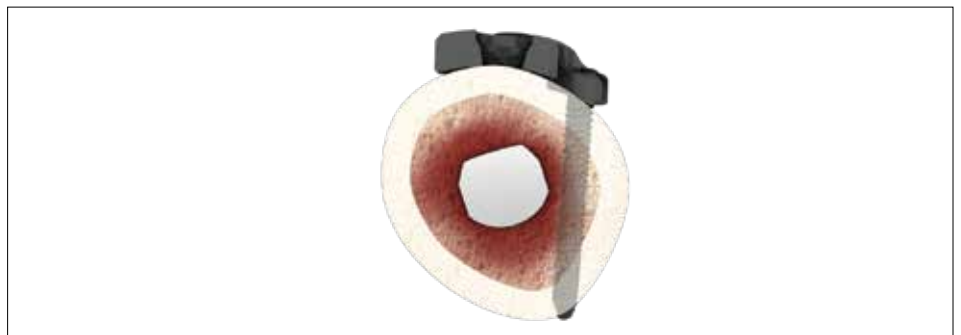

# 5.0mm Variable Angle Extension Arm

## Extension arm removal

Toggle the extension arm for disassembling by hand or use standard pliers.

### CAUTION

The variable angle extension arm is a single-use, single application device. If the device has been previously used intraoperatively, discard the device and use a new extension arm.

# 5.0mm Cable Plug

The 5.0mm cable plug (ref 661002S) is designed to be used in combination with the 5.0mm AxSOS 3 System. It is used in combination with cobalt chrome cables of 2mm diameter.

The 5.0mm cable plug helps ensure a stable positioning of a cerclage cable on the plate and helps prevent slipping in oblique cable applications.

**NOTICE**

When used with AxSOS 3 Distal Lateral Femur, only use the cable plug in the universal holes in the shaft of the plate.

Hole number 17 in long AxSOS 3 Distal Lateral Femur Plates is designed slightly in an oblique way to avoid conflicting protection sleeves with the targeting instrumentation. Despite the slightly oblique orientation of hole number 17 one can place a cable plug.

**NOTICE**

When used with the broad or narrow AxSOS 3 Waisted Compression Plates, only use the cable plug in the universal holes and not oblong compression holes of the plates.

**NOTICE**

Do not mix stainless steel cables or wires with AxSOS 3 Plates. Only use cobalt chrome wires or cables. Tests have been performed with the Vitallium (cobalt chrome) cables of the Dall-Miles Cable System from Stryker.

**CAUTION**

In case of mixing non-locking and locking in the overall plate construct always follow the principle of "lag before lock".

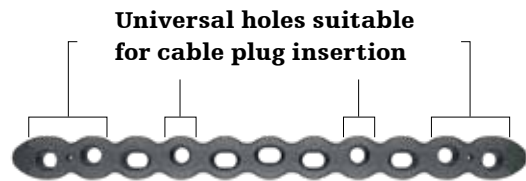
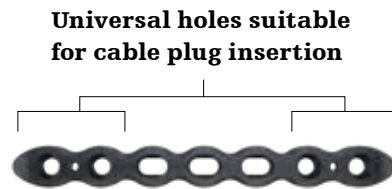
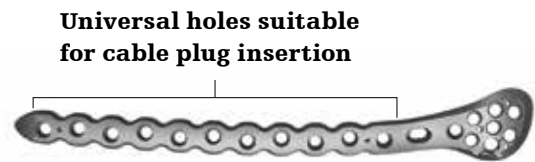

## 5.0mm Cable Plug

### Cable plug insertion and cable application

Insert an AxSOS 3 Cable Plug by clicking it into the appropriate universal hole (fig. 36). At least one “click” shall be emitted to allow for engagement of the cable plug and the threads of the universal hole. Alternatively the AxSOS 3 Cable Plug can be screwed in by turning at least half a turn clockwise.

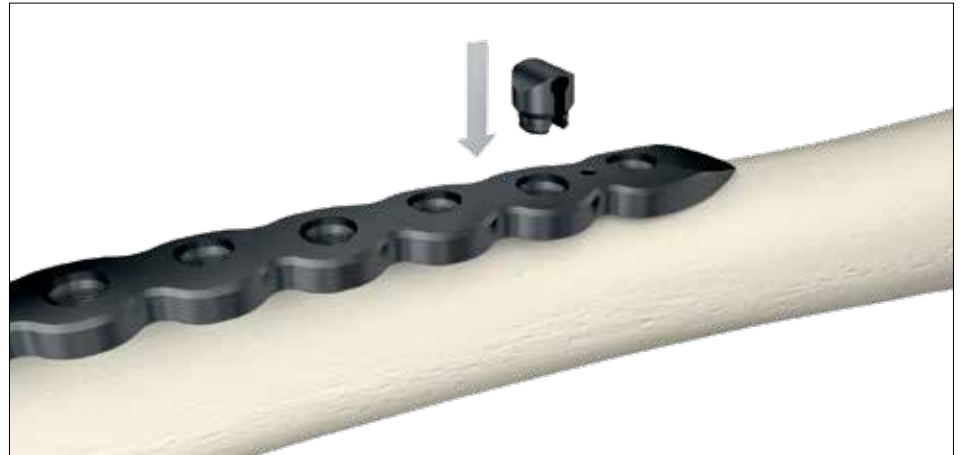

**Fig. 36**

Insert a cable through the eyelet of the cable plug. In case one uses a beaded cable, slide the sleeve onto the cable before sliding through the cable plug (fig. 37).



**Fig. 37**

Proceed as described in the respective instructions for use of the cabling system.

Then, tighten the cable and crimp the sleeve which usually sits aside the plate. As a last step, cut the cable near the crimped sleeve (fig. 38).



**Fig. 38**

## 5.0mm Cable Plug

### Cable plug removal

If a cable plug has to be removed simply cut or remove the cable and then unscrew the cable plug counterclockwise (fig. 39). The cable plug can be re-seated up to 3 times intraoperatively. As any implant, cable plugs are for single patient use only.

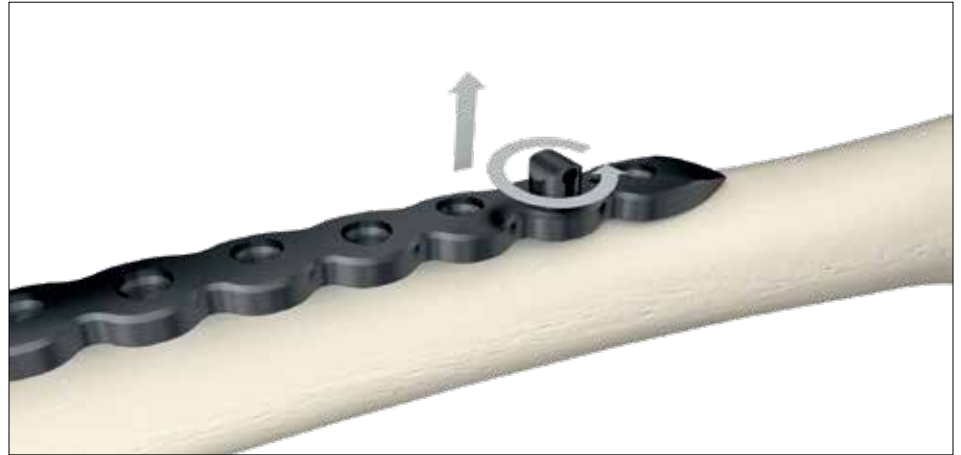
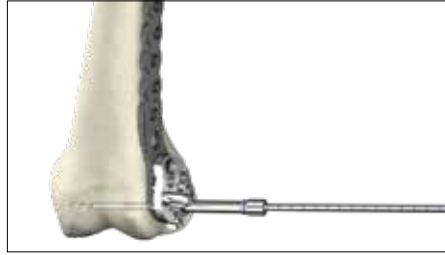

Fig. 39

## Additional tips

### ⚠ CAUTION

1. Always use the **threaded drill sleeve** when drilling for locking screws.



Freehand drilling can lead to a misalignment of the screw and result in screw cross-threading during insertion. It is essential to drill the core hole in the correct trajectory to facilitate accurate insertion of the locking screws.

### ⚠ CAUTION

2. It is best to insert the screw **manually** to ensure proper alignment in the core hole which aligns the screws so it locks properly after being fully advanced. It is recommended to start inserting the screw using **“the three finger technique”** on the teardrop handle.



Locking screws should be aligned perpendicular to the plate/hole. If the locking screw head does not immediately engage the plate thread, reverse the screw and re-insert it once it is properly aligned.

### ⚠ CAUTION

3. Use low speed only and **do not apply axial pressure** if power screw insertion is selected. Stop power insertion approximately 1cm before engaging the screw head in the plate.



Power can negatively affect screw insertion if used improperly, damaging the screw / plate interface (screw jamming). This can lead to screw heads breaking or being stripped.

### ⚠ CAUTION

4. It is advisable to **tap hard (dense) cortical bone** before inserting a locking screw. Use 5.0mm tap (ref 702773).



The spherical tip of the tap is designed to precisely align with the instrument in the pre-drilled core hole during thread cutting. This will facilitate subsequent screw placement.

### ⚠ CAUTION

5. **Do not use power for final insertion of locking screws.** It is imperative to engage the screw head into the plate using the torque limiter. Ensure that the screwdriver tip is fully seated in the screw head, but do not apply axial force during final tightening. If the screw stops short of final positioning, back up and advance the screw again (with torque limiter on).

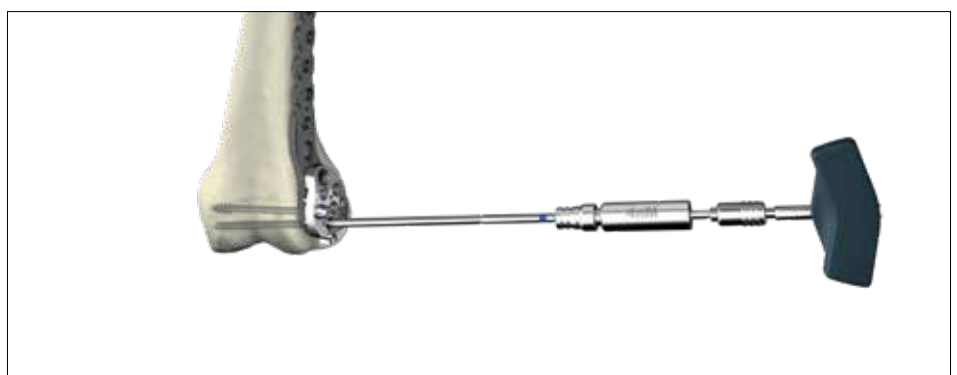

# SPS Titanium – AxSOS 3 Titanium compatibility chart

## Screws

The chart shows the compatibility of SPS Small and Basic Fragment Titanium screws with AxSOS 3 Plates and vice-versa.

			AxSOS 3 Ti 4.0mm						AxSOS 3 Ti 5.0mm								SPS 3.5mm			SPS 4.5mm				SPS 2.7mm				
			661014/-095	661410/-520	607310/-400	607410/-500	661612/-640	661004	661114/-195	661714/-850	608230/-350	608020/-150	608445/-550	661922/-975	661308/-320	661005	991088S	661002S	603010/-090	604010/-060	604210/-260	601014/-150	602030/-150	602245/-400	602420/-550	605008/-060		
			4.0mm locking Ti screw	3.5mm cortex Ti screw	4.0mm cancellous Ti screw - full thread	4.0mm cancellous Ti screw - partial thread	3.5mm cortex shaft Ti screw	4.0mm blind screw	5.0mm locking screw	4.5mm cortex Ti screw	6.0mm cancellous Ti screw - TL-16	6.0mm cancellous Ti screw - full thread	6.0mm cancellous Ti screw - TL-32	4.5mm cortex shaft Ti screw	5.0mm periprosthetic locking screw	5.0mm blind screw	5.0mm variable angle extension arm*	5.0mm cable plug	SPS 3.5mm Ti cortical screw	SPS 4.0mm Ti cancellous full	SPS 4.0mm Ti cancellous partial	SPS 4.5mm Ti cortical screw	SPS 6.5mm Ti cancellous 16.0mm	SPS 6.5mm Ti cancellous 32.0mm	SPS 6.5mm Ti cancellous full thread	SPS 2.7mm Ti cortical screw		
Plates	AxSOS 3 Ti 4mm	627302/-352	Proximal lateral tibia plate	X	X	X	X	X	X										X	X	X							
		627404/-452	Distal medial tibia plate	X	X	X	X	X	X											X	X	X						
		627454/-500	Distal anterolateral tibia plate	X	X	X	X	X	X											X	X	X						X
		627704/-752	Proximal medial tibia plate	X	X	X	X	X	X											X	X	X						
		627203/-250	Proximal lateral humerus plate	X	X	X	X	X	X											X	X	X						
		627502/-520	4mm compression plate	X	X	X	X	X	X											X	X	X						
Plates	AxSOS 3 Ti 5mm	627604/-650	Distal lateral femur plate							X	X	X	X	X	X	X	X	X				X						
		627532/-552	5mm compression plate narrow							X	X	X	X	X	X	X	X	X				X						
		627566/-582	5mm compression plate broad							X	X	X	X	X	X	X	X	X				X						
Plates	SPS Small Fragment	621423/-436	T-plate		X	X	X	X											X	X	X							
		621463/-468	Oblique T-plate		X	X	X	X											X	X	X							
		621443/-450	Cloverleaf plate		X	X	X	X											X	X	X							
		621122/-134	One third tubular plate		X	X	X	X											X	X	X							
Plates	SPS Basic Fragment	620413/-413	T-plate																			X	X	X	X			
		620454/-458	T-buttruss plate																			X	X	X	X			
		620704/-706	L-buttruss plate, left																			X	X	X	X			
		620754/-758	L-buttruss plate, right																			X	X	X	X			

\* This product is not CE marked in accordance with applicable EU regulations and directives. Stryker is not marketing or distributing this product in the EU. Any reference to this product is for presentation purposes only.



This document is intended solely for the use of healthcare professionals. A surgeon must always rely on his or her own professional clinical judgment when deciding whether to use a particular product when treating a particular patient. Stryker does not dispense medical advice and recommends that surgeons be trained in the use of any particular product before using it in surgery.

The information presented is intended to demonstrate a Stryker product. A surgeon must always refer to the product label and/or Instructions for Use, including the instructions for Cleaning and Sterilization (if applicable), before using any Stryker product. Products may not be available in all markets because product availability is subject to the regulatory and/or medical practices in individual markets. Please contact your Stryker representative if you have questions about the availability of Stryker products in your area.

The Instructions for Use, Operative Techniques, Cleaning instructions, patient information leaflets and other associated labeling may be requested online at [www.ifu.stryker.com](http://www.ifu.stryker.com) or [www.stryker.com](http://www.stryker.com).

If saving the Instructions for Use, Operative Techniques, Cleaning instructions from the above mentioned websites, please make sure you always have the most up to date version prior to use.

Stryker Corporation or its divisions or other corporate affiliated entities own, use or have applied for the following trademarks or service marks: AxSOS 3, Stryker.

All other trademarks are trademarks of their respective owners or holders.

The products listed above are CE marked.

This document is not applicable to US and Canada

**Content ID: AxSOS-ST-65, 03-2021**

**Copyright © 2021 Stryker**



Manufacturer:  
**Stryker GmbH**  
Bohnackerweg 1  
2545 Selzach, Switzerland  
[www.stryker.com](http://www.stryker.com)