

stryker

Aequalis[®]

Resurfacing Head

Operative technique



This publication sets forth detailed recommended procedures for using Stryker devices and instruments. It offers guidance that you should heed, but, as with any such technical guide, each surgeon must consider the particular needs of each patient and make appropriate adjustments when and as required.

Important

- The patient should be advised that the device cannot and does not replicate a normal healthy bone, that the device can break or become damaged as a result of strenuous activity or trauma and that the device has a finite expected service life.
- Removal or revision of the device may be required sometime in the future.
- Cleaning and sterilization information is provided in the applicable instructions for use.
- Non-sterile devices, including implants and instruments, must be cleaned and sterilized prior to use, in accordance with validated methods.
- Devices that are able to be disassembled should be disassembled prior to point-of-use processing. Additionally, devices with movable components that do not facilitate disassembly should be manually articulated during the point-of-use processing step in order to evacuate additional soils.
- Please remember that the compatibility of different product systems has not been tested unless specified otherwise in the product labeling.
- Consult Instructions for Use (<https://ifu.stryker.com>) for a complete list of potential adverse effects and adverse events, contraindications, warnings and precautions.
- The surgeon must advise patients of surgical risks, and make them aware of adverse effects and alternative treatments.
- An implant whose packaging is open or damaged or whose expiration date has passed must not be used. Every precaution must be taken to ensure sterility when opening the packaging of the implant and during implantation.

Aequalis

Resurfacing Head

Table of contents

Instrumentation	4
Color coding	5
Operative technique	6-15
Indications.....	6
Contraindications.....	6
Adverse events.....	6
Preoperative planning	6
Deltopectoral approach.....	7
Supero-lateral approach.....	7
Preparation of humeral head.....	8
Humeral head sizing	8
Confirming head size and insertion of alignment pin	9
Humeral head reaming	10
Initial trial head—assessing the depth of reaming	11
Stem preparation.....	12
Final trial head.....	13
Glenoid preparation (when applicable).....	14
Final implant seating.....	14
Closure	15
Postoperative care.....	15
Instrumentation	16-18
Box 1: Upper tray	16
Box 1: Lower tray.....	17
Box 2	18
Implants	19

The Aequalis Resurfacing Humeral Head was developed in conjunction with Drew Miller, MD, of Atlanta, GA.

The Aequalis Resurfacing Humeral Head dimensions follow the recommendation published in the anatomical study by Gilles Walch, MD, and Pascal Boileau MD, J Bone Joint Surg Br.; 1997, 79(5):857-65.

Instrumentation

The color-coding scheme allows for a quick identification of the group of instruments to be used for each given humeral head size.

Head size	Instruments and trial color	Stem punch color
-----------	-----------------------------	------------------

Box 1: Upper tray

37mm x 13.5mm	Yellow	30mm
39mm x 14mm	Green	
41mm x 15mm	Blue	
43mm x 16mm	Pink	



Box 1: Lower tray

46mm x 17mm	Yellow	35mm
48mm x 18mm	Green	
50mm x 16mm	Blue	
50mm x 19mm	Pink	
52mm x 19mm	Grey	



Box 2

52mm x 23mm	Yellow	40mm
54mm x 23mm	Green	
54mm x 27mm	Blue	



Color coding

Step 1: Head sizing

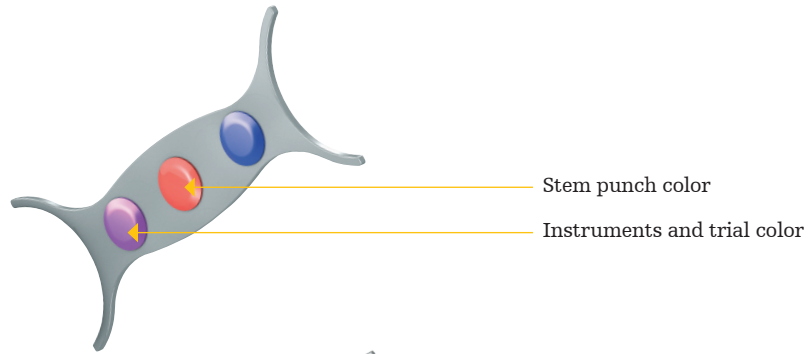

Step 2: Insertion of alignment pin

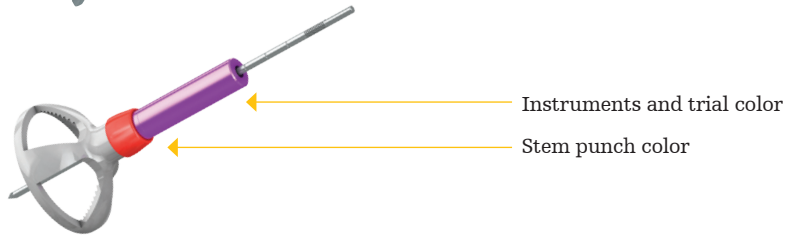

Step 3: Reaming

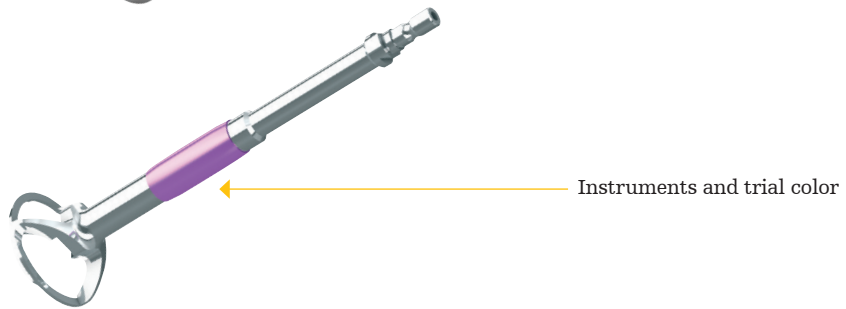

Step 4: Initial trial head Assessing the depth of reaming



Step 5: Preparation of stem

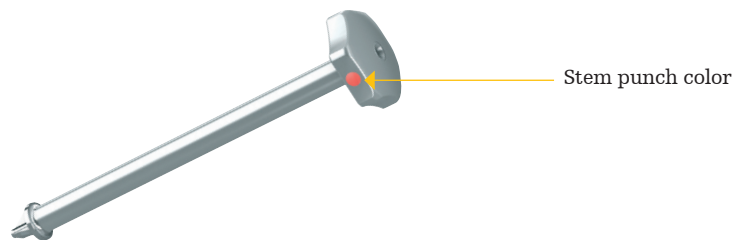

Step 6: Final trial head



Operative technique

Indications

The Aequalis Resurfacing Head is indicated as a total or hemi shoulder joint replacement where the humeral head and neck are of sufficient bone stock and the rotator cuff is intact or reconstructible.

The replacement of the joint with this device is indicated to relieve severe pain or significant disability caused by degenerative pathologies: osteoarthritis, rheumatoid arthritis, post-traumatic arthritis, and primary and secondary necrosis of the humeral head. The resurfacing implant is intended for uncemented use only. The glenoid component is for cemented use only.

Contraindications

- Systemic infection
- Fever and/or local inflammation
- Rapid joint destruction or bone resorption apparent on roentgenograms
- Elevation of sedimentation rate unexplained by other disease, elevation of WBC count
- Distant foci of infection from genitourinary, pulmonary, skin and other sites, dental focus infection that may cause haematogenous spread to the implant site
- Use of this implant is contraindicated in the presence of significant injury to the upper brachial plexus
- Insufficient bone stock
- Nonfunctional deltoid or external rotator muscles
- Important and nonreparable rupture of the rotator cuff, or where neuromuscular disease compromising the affected limb would render the procedure unjustifiable (e.g., joint neuropathy)
- Known allergy to one of the materials
- Patient pregnancy

The complete list of contraindications can be found in the “instructions for use” packaged with the implants.

Adverse events

The following are the most frequent adverse events after shoulder arthroplasty: component loosening, dislocation, subluxation, iatrogenic fracture and traumatic fracture below the humeral component and possible metal sensitivity.

Preoperative planning

Radiographs should be templated preoperatively to anticipate humeral head size. (Figure 1)

Both AP and axillary x-rays are critical in determining humeral head bone stock. CT scanning may also be used to further delineate humeral head anatomy, bone stock, and deformity.

The use of the x-ray templates may be used during preoperative planning to offer an estimate of the insertion depth of the alignment pin required to engage the lateral cortex. Use the calibration marks on the alignment pin to confirm length of insertion. This feature is intended to prevent the alignment pin from inserting too far, risking injury to the axillary nerve.

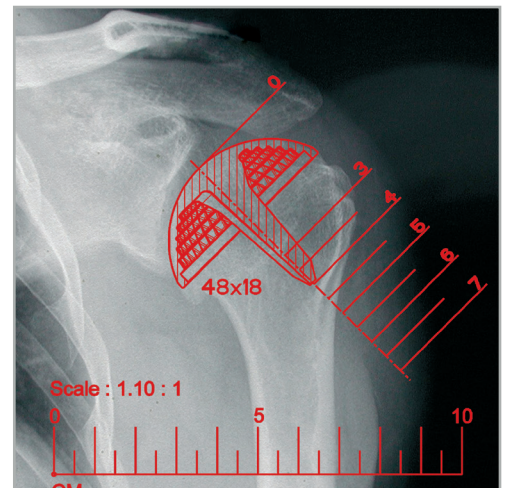

Figure 1

Deltopectoral approach

An incision is made from the tip of the coracoid along the deltopectoral interval. (Figure 2) The cephalic vein is mobilized. A deep self-retaining retractor is used to retract the deltoid laterally and the pectoralis medially. The upper portion of the pectoralis may be released in order to improve external rotation.

The clavipectoral fascia is incised along the lateral border of the conjoined tendon. The conjoined tendon is retracted to expose the subscapularis and the circumflex vessels. These vessels may be ligated to maintain hemostasis throughout the remainder of the procedure. The axillary nerve can be palpated and protected.

The subscapularis is then released and reflected to expose the proximal humerus. The humeral head is gradually externally rotated as the subscapularis and capsule are reflected from the proximal humerus. The inferior capsule is released from anterior to posterior, exposing humeral head osteophytes. The humeral head is then delivered out of the incision. (Figure 3)

(Continued on next page - "preparation of humeral head")

Supero-lateral approach

The incision is made from the AC joint along the anterior border of the acromion, extending laterally approximately 4cm. (Figure 4) The deltoid is split along the interval between the anterior and middle deltoid, and the anterior deltoid is released from the acromion. A stay suture is placed laterally to protect the axillary nerve. Care should be taken to preserve the coraco-acromial ligament for later repair along with the deltoid. An acromioplasty and/or a distal clavicle resection may be performed.

A deep self-retaining retractor is used to retract the deltoid and expose the humeral head. The rotator interval capsule is incised, and the subscapularis is reflected from its humeral insertion. In this approach, it may be possible to preserve some of the inferior subscapularis, but the entire humeral head must be exposed to remove humeral osteophytes. With external rotation, adduction, and extension, the humeral head is delivered out of the incision. (Figure 5)

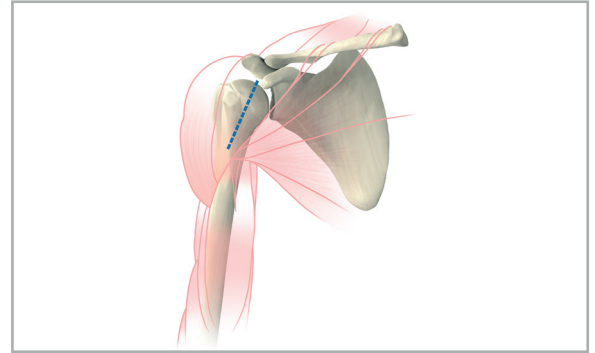

Figure 2

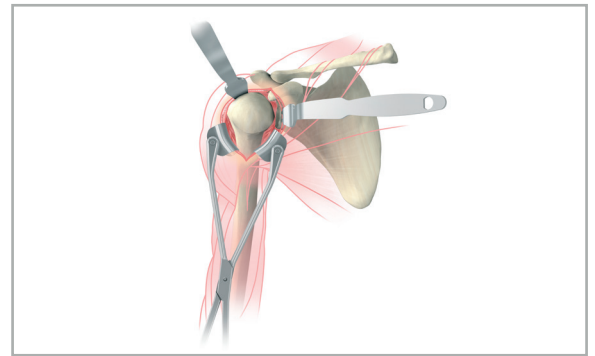

Figure 3

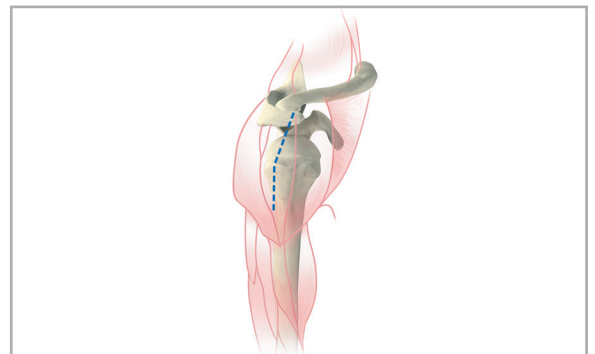

Figure 4



Figure 5

Preparation of humeral head

Retractors (Figure 6) designed specifically for exposure of the humeral head are used to reflect the capsule, rotator cuff, and biceps tendon. Next, care must be taken to remove all osteophytes circumferentially in order to expose the anatomic neck of the proximal humerus. This step is critical because head sizing and head orientation are based off the anatomic neck.

Humeral head sizing

Once osteophytes are removed circumferentially to expose the humeral anatomic neck, the humeral head may be sized. The diameter of the humeral head is determined by using the head sizer (Figure 7) to measure along the superior-inferior and anterior-posterior axes while assuring that both tips are in close contact with the anatomic neck. If between sizes, the smaller size is usually selected.

The color-coding scheme allows a quick identification of the group of instruments to be used for each given humeral head size.

The color of the metallic button at the end of the head sizer corresponds to the color of the appropriate pin positioning guide, reamer, initial, and final trial heads to be used in subsequent steps.

The color of the central plastic button corresponds to the color of the appropriate stem punch to be used in a subsequent step.

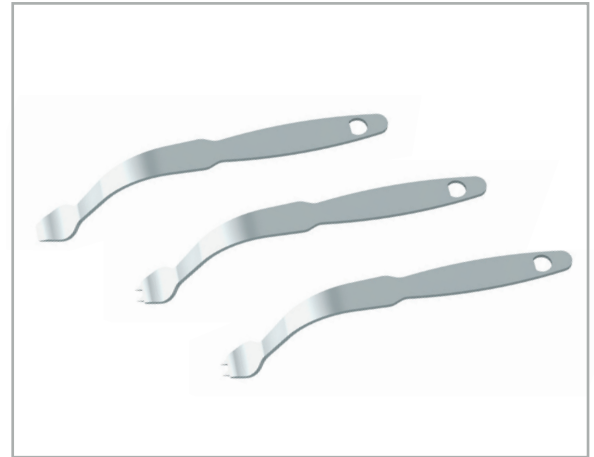

Figure 6

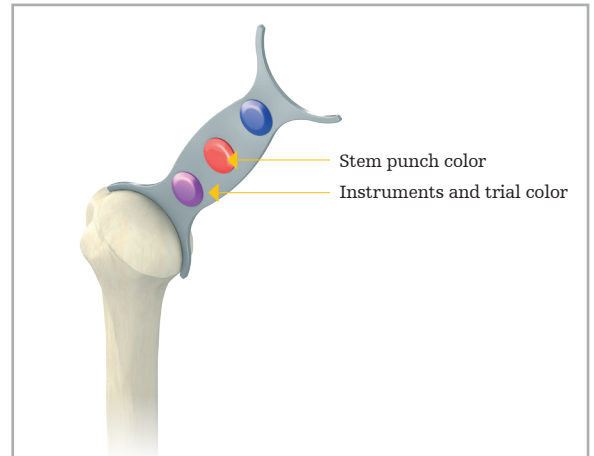

Figure 7

Confirming head size and insertion of alignment pin

The humeral head size is confirmed by using the pin positioning guide.

The initial guide corresponds to the color of the head sizer chosen in the previous step.

The pin positioning guide should be placed such that there is complete contact with the anatomic neck of the humerus, and the articular surface should be uniformly covered. (Figure 8)

This represents a final determination of head size, and assures that the alignment pin is placed along the axis of the anatomic neck. The alignment pin must be placed in the center of the humeral head.

Note:

If the actual humeral head appears to be in between sizes, the smaller size is usually selected.

The pin positioning guide is then hand-held in place, and the alignment pin is inserted using power until the alignment pin penetrates the lateral cortex. Placement through the lateral cortex will prevent pin migration during subsequent steps. (Figure 9)

Once the alignment pin is placed, the positioning guide is removed. A final check should be performed to ensure that the alignment pin has been inserted into the center of the humeral head. (Figure 10) It is important that the alignment pin remains straight throughout the surgical procedure, otherwise it should be exchanged.



Figure 8

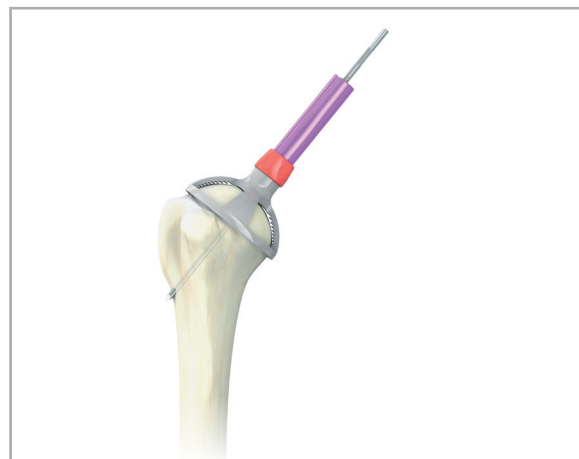

Figure 9

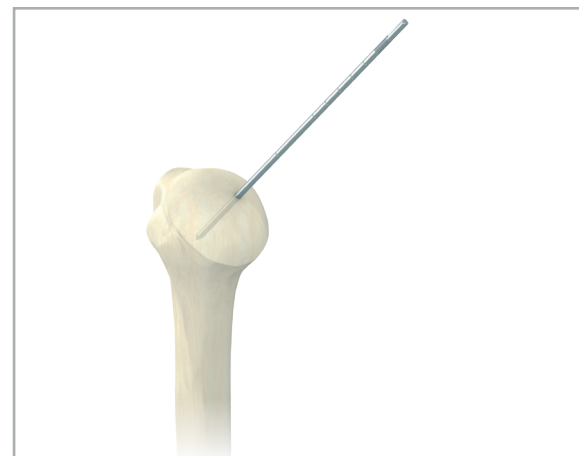

Figure 10

Humeral head reaming

The appropriate size reamer is selected, based on previous selection of the pin positioning guide, ensuring that the color of the two instrument handles match.

The reamer is assembled to power and then passed over the alignment pin. (Figure 11)

The reamer is started prior to engaging the humeral head. The humeral head is reamed until the border of the reamer is in contact with the humeral neck.



Figure 11

A visual control of the depth of reaming can be achieved by observing the humeral head through the windows in the reamer as well as by observing the periphery of the reamer and its position with respect to the humeral neck. (Figure 12)



Figure 12

The reamer has been designed such that the advancing edge clears enough bone to allow easy seating of the implant. The reamer creates a ridge against which the final implant will rest. (Figure 13)

Note:

Care should be taken to prevent the reamer edges from damaging the rotator cuff insertion.

A rongeur is used to clear any remaining osteophytes.



Figure 13

Initial trial head—assessing the depth of reaming

Before preparation of the central stem, the initial trial head (without the stem) is used to assess the reamed surface of the humeral head and assure conformity with the internal surface of the implant.

The initial trial head is used to confirm size before preparing the stem.

The color of the appropriate initial trial head is matched to the color of the reamer and the instruments used in the previous steps. The initial trial head is positioned over the alignment pin. (Figure 14)

Proper fit can be visualized through the windows in the trial. The initial trial head should rest completely on the humeral neck.

Note:

In cases of non-uniform contact, it may be necessary to perform additional reaming or to re-ream if a different head size is finally selected.

The initial trial head is identical to the final trial head except for the stem.

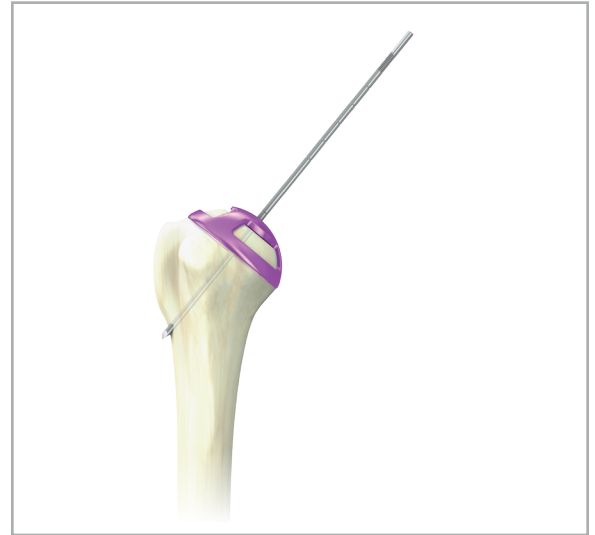

Figure 14

Stem preparation

The tri-fin stem allows for rotational control of the implant.

A cannulated stem punch is used to create a precise path for the final implant. The stem punch is smaller in length and width than the final implant, allowing for an additional press-fit of the stem on the final implant.

Three stem punches are available according to the humeral head size selected. The color code allows easy selection of the appropriate stem punch.

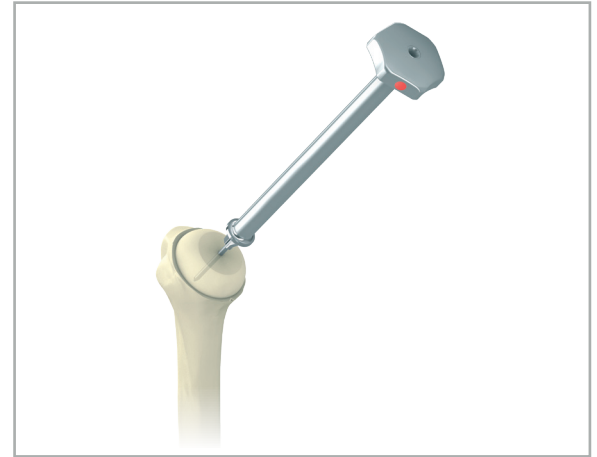

Figure 15

The stem punch is positioned over the alignment pin and oriented with one fin pointing laterally and two fins pointing medially. Care is taken to avoid bending the alignment pin, maintaining a central location of the stem punch to the reamed flat on the dome of the humeral head. The stem punch is impacted up to the collar. (Figures 15 and 16)

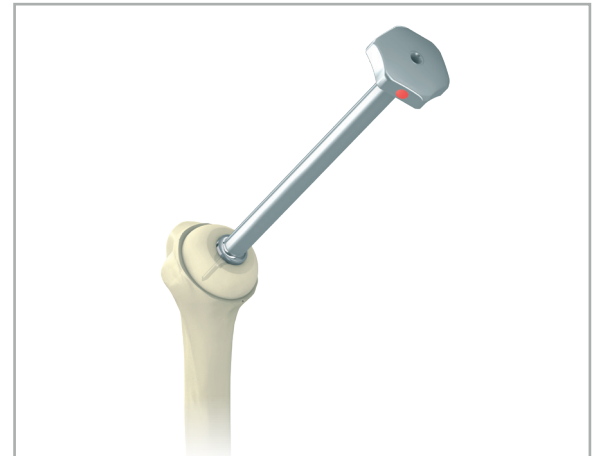

Figure 16

The stem punch is removed, leaving the alignment pin in place. (Figure 17)

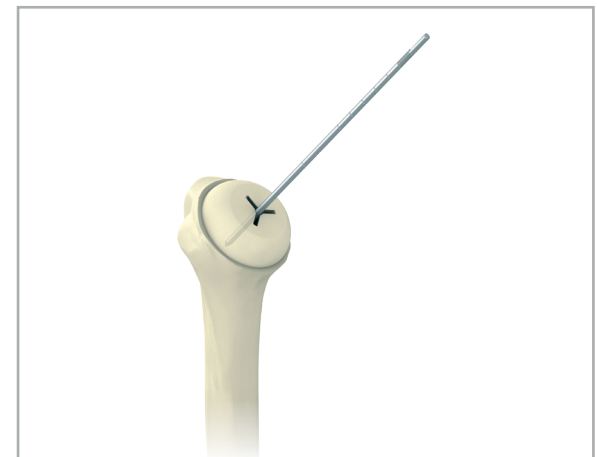

Figure 17

Final trial head

The stem on the final trial head maintains stability during trial reduction.

The appropriate size and color of the final trial head is selected and then positioned over the alignment pin (Figures 18 and 19) and impacted into place using the cannulated impactor. (Figure 20)

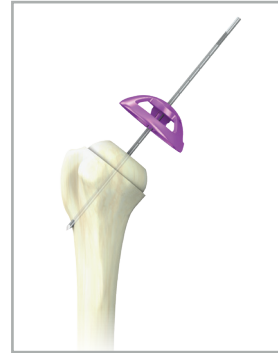

Figure 18



Figure 19

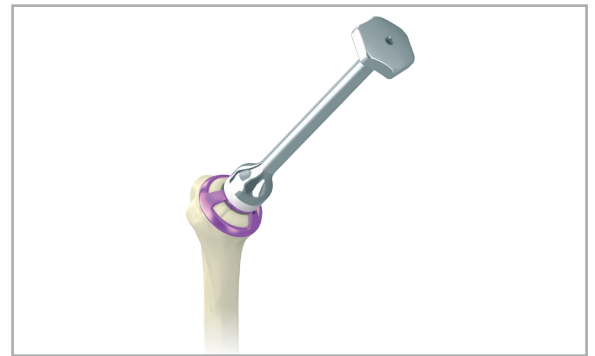

Figure 20

Visual inspection of the windows in the final trial head confirms complete seating of the trial. The alignment pin is removed with the pin puller (Figure 21) and a trial reduction is performed.

Soft tissue balance is assessed and additional soft tissue releases may be performed.

As in general shoulder arthroplasty, with the humerus in neutral rotation and slight abduction, posterior stress should result in approximately 50% posterior translation of the implant.

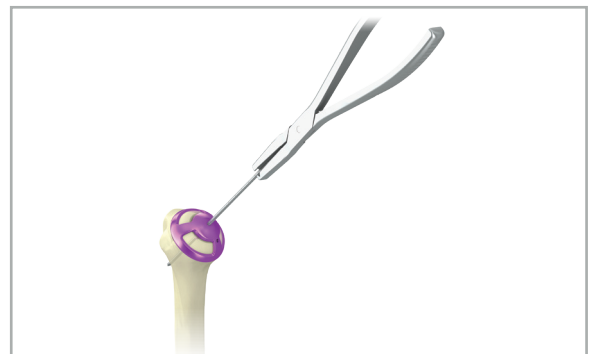

Figure 21

The subscapularis should be able to reach its point of reattachment. The final trial head can then be removed with the trial head clamp. (Figure 22)

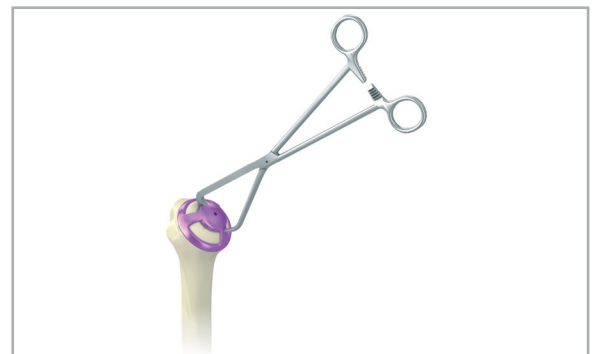

Figure 22

Glenoid preparation (when applicable)

After removal of the final trial head, the glenoid can be prepared for insertion of a glenoid component, biological resurfacing, or further soft tissue preparation such as labral excision, capsular release, or capsular plication.

Note:

When retracting the humeral head, care must be taken to avoid damage to the reamed surface of the humeral head. The final trial head may be left in place to protect the reamed surface.

The Aequalis Resurfacing Head is compatible with the full range of Aequalis Glenoids. Refer to the Aequalis Glenoid operative technique for more detailed information.

Final implant seating

After final irrigation and exposure of the reamed surface of the humeral head, the final component is positioned by hand to properly orient the stem with the tri-fin pattern previously created with the stem punch. (Figures 23 and 24)

The impactor is then used to impact the final implant to its fully seated position. (Figure 25)

The implant should completely contact the ridge created by the reamer. (Figure 26)

The humerus is then reduced and proper soft tissue balance should be confirmed.



Figure 23

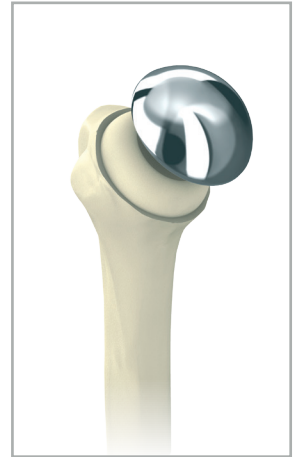

Figure 24



Figure 25

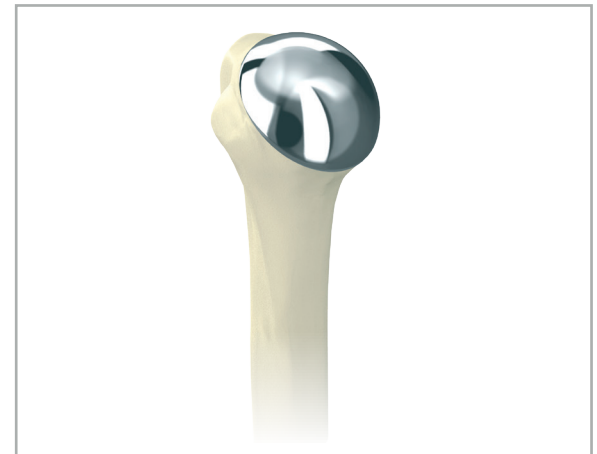

Figure 26

Closure

The subscapularis is repaired in a tendon-to-tendon fashion if it was released in an intra-tendinous plane, or directly to the proximal humerus adjacent to the implant. When repairing directly to bone, the tendon is usually recessed medially to allow for increased external rotation. Suture anchors may also be utilized. The amount of external rotation without undue tension (“safe zone”) is observed. Routine closure is then performed and an immobilizer is placed (Figure 27).

Postoperative care

Aftercare is the same as routine shoulder arthroplasty and is guided on an individual basis according to intraoperative pathology, quality of soft tissue, and the patient’s ability to comply with postoperative rehabilitation.

On postoperative day one, pendulum exercises and passive range of motion within the safe zone, established intraoperatively, are usually begun. The immobilizer is used for protection for the first six weeks, at which time passive stretching and isometrics of the deltoid, rotator cuff, and scapular muscles are started.

These exercises are advanced over the next three to six months, at which time recreational activities are allowed.

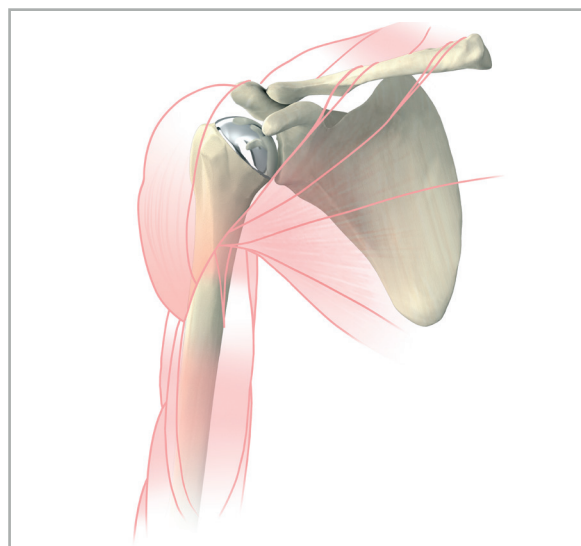
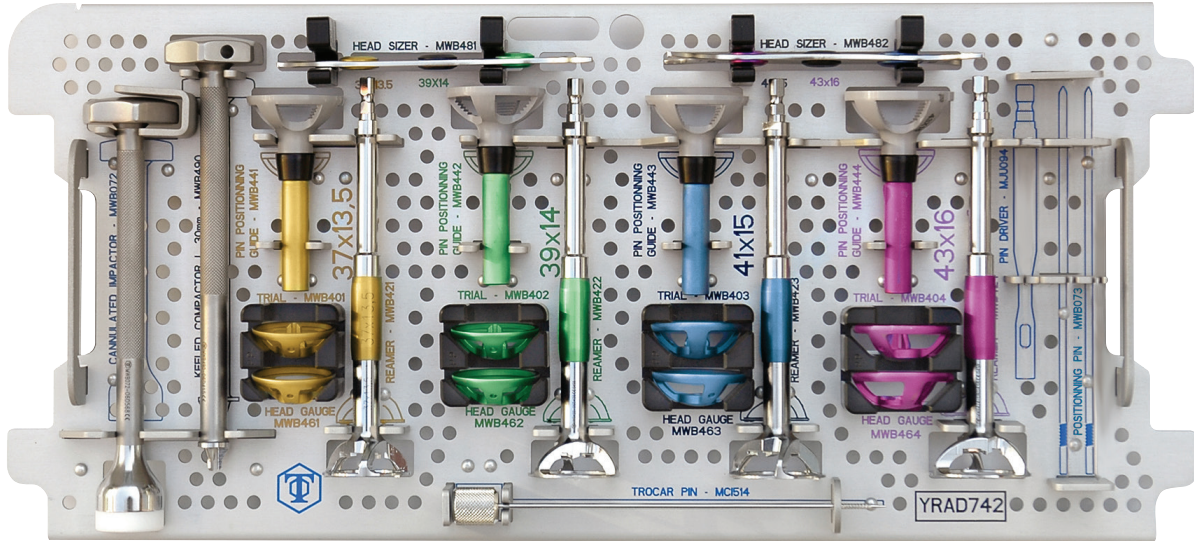

Figure 27

Instrumentation

Box 1: Upper tray



Ref. YKAD 74/2

Reference	Instruments	Color
MWB481	Head sizer	37 x 13.5
MWB482		39 x 14
MWB441	Pin positioning guide	41 x 15
MWB442		43 x 16
MWB443		
MWB444		
MWB421	Reamer	37 x 13.5
MWB422		39 x 14
MWB423		41 x 15
MWB424		43 x 16
MWB461	Initial trial head	37 x 13.5
MWB462		39 x 14
MWB463		41 x 15
MWB464		43 x 16
MWB401	Final trial head	37 x 13.5
MWB402		39 x 14
MWB403		41 x 15
MWB404		43 x 16
MWB490	Stem punch 30mm	
MCI514	Cleaning rod	
MWB372	Impactor handle	
MWB373	Impactor tip	



Box 1: Lower tray

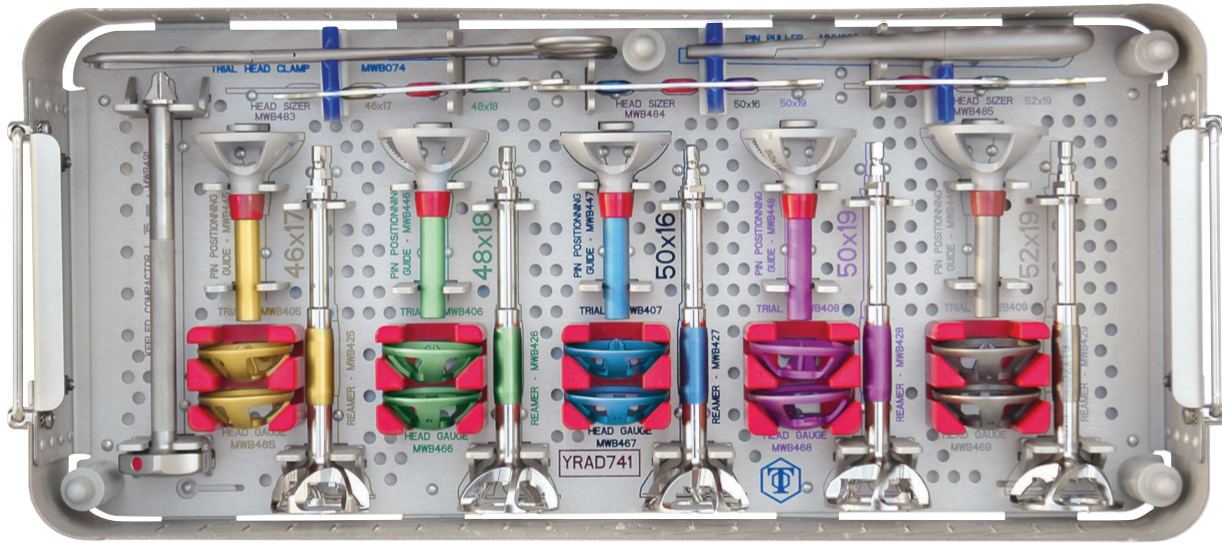

Ref. YKAD 74/1

Reference	Instruments	Color	
MWB483	Head sizer	46 x 17	48 x 18
MWB484		50 x 16	50 x 19
MWB485		52 x 19	
MWB445	Pin positioning guide	46 x 17	
MWB446		48 x 18	
MWB447		50 x 16	
MWB448		50 x 19	
MWB449		52 x 19	
MWB425	Reamer	46 x 17	
MWB426		48 x 18	
MWB427		50 x 16	
MWB428		50 x 19	
MWB429		52 x 19	
MWB465	Initial trial head	46 x 17	
MWB466		48 x 18	
MWB467		50 x 16	
MWB468		50 x 19	
MWB469	52 x 19		
MWB405	Final trial head	46 x 17	
MWB406		48 x 18	
MWB407		50 x 16	
MWB408		50 x 19	
MWB409		52 x 19	
MWB491	Stem punch 35mm		
MWB074	Trial head clamp		
MVV062	Pin puller		



Box 2

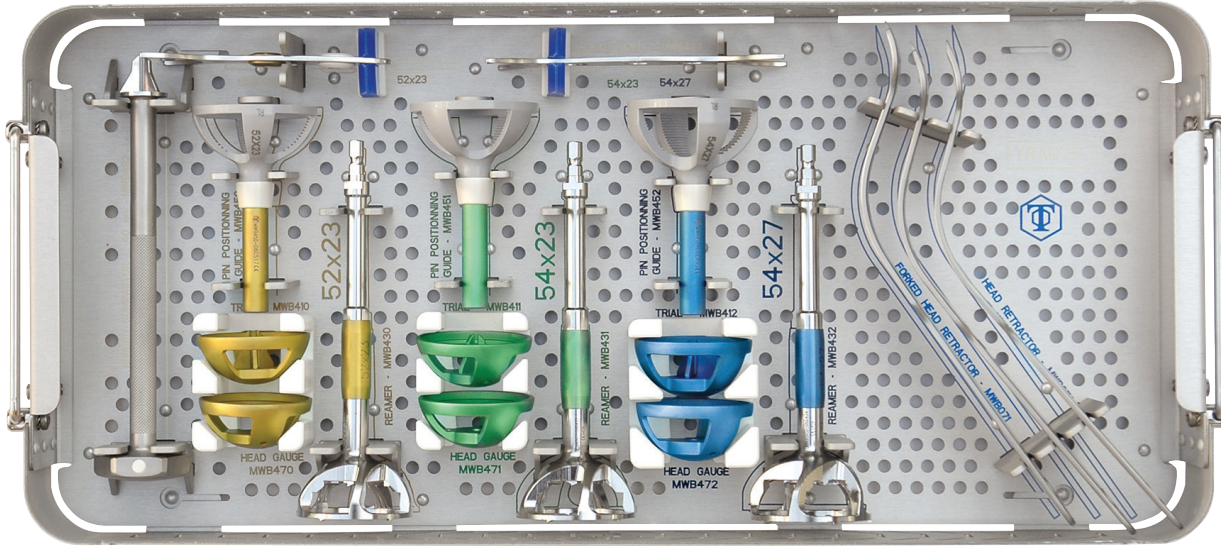

Ref. YKAD75

Reference	Instruments	Color
MWB486	Head sizer	52 x 23
MWB487		54x 23 54 x 27
MWB450	Pin positioning guide	52 x 23
MWB451		54 x 23
MWB452		54 x 27
MWB430	Reamer	52 x 23
MWB431		54 x 23
MWB432		54 x 27
MWB470	Initial trial head	52 x 23
MWB471		54 x 23
MWB472		54 x 27
MWB410	Final trial head	52 x 23
MWB411		54 x 23
MWB412		54 x 27
MWB492	Stem punch 40mm	
MWB070	Resurfacing head extractor	
MWB071	Forked resurfacing head retractor (x2)	



Implants

Reference	Size	Stem length
DWD801	Head 37 x 13.5	30mm
DWD802	Head 39 x 14	30mm
DWD803	Head 41 x 15	30mm
DWD804	Head 43 x 16	30mm
DWD805	Head 46 x 17	35mm
DWD806	Head 48 x 18	35mm
DWD807	Head 50 x 16	35mm
DWD808	Head 50 x 19	35mm
DWD809	Head 52 x 19	35mm
DWD810	Head 52 x 23	40mm
DWD811	Head 54 x 23	40mm
DWD812	Head 54 x 27	40mm



Single use items

Reference	Description
DWD064	3 x 170 alignment pin



This document is intended solely for the use of healthcare professionals. A surgeon must always rely on his or her own professional clinical judgment when deciding whether to use a particular product when treating a particular patient. Stryker does not dispense medical advice and recommends that surgeons be trained in the use of any particular product before using it in surgery.

The information presented is intended to demonstrate a Stryker product. A surgeon must always refer to the package insert, product label and/or instructions for use, including the instructions for cleaning and sterilization (if applicable), before using any Stryker product. Products may not be available in all markets because product availability is subject to the regulatory and/or medical practices in individual markets. Please contact your Stryker representative if you have questions about the availability of Stryker products in your area.

The instructions for use, operative techniques, cleaning instructions, patient information leaflets and other associated labeling may be requested online at ifu.stryker.com or stryker.com. If saving the instructions for use, operative techniques, cleaning instructions from the above mentioned websites, please make sure you always have the most up to date version prior to use.

Stryker Corporation or its divisions or other corporate affiliated entities own, use or have applied for the following trademarks or service marks: Aequalis, Stryker, Tornier. All other trademarks are trademarks of their respective owners or holders.

Content ID: AP-015558B 02-May-2022

Copyright © 2022 Stryker

Manufacturer:

Tornier SAS
161 Rue Lavoisier
38330 Montbonnot Saint Martin
France
t: +33 (0)4 76 61 35 00
stryker.com