

Reprocessed by



Sustainability Solutions

Instructions for Use

Reprocessed LigaSure™ Blunt Tip Laparoscopic Sealer/Dividers (Model LF1637)

Reprocessed Device for Single Use

Caution: Federal (U.S.A.) law restricts this device to sale by or on the order of a physician.

- STERILE
- NOT MADE WITH NATURAL RUBBER LATEX

Explanation of Symbols

 Sterilized by Ethylene Oxide Gas



Date of Reprocessing



Use by Date



Do Not Reuse



See Instructions For Use

LF1637

Compatible with:

FORCETRIAD SW v3.5 – v4.0

VLFT10GEN SW v1.1 – v2.0.1.13

NOTE: Devices with a Valleylab Plug are NOT compatible with VLFT10GEN SW v1.1.5.4 or higher

Reprocessed LigaSure Blunt Tip Laparoscopic Sealer/Dividers Description

The Reprocessed LigaSure™ Blunt Tip Laparoscopic Sealer/Divider (Model LF1637) is a bipolar electro-surgical instrument for use in performing laparoscopic surgical procedures using Covidien™ electro-surgical generators that include vessel sealing capability. Please refer to the cover page for details on compatible generator models and software versions. If the software version on your generator is lower than required, contact Covidien about software upgrades.

The outer diameter of the instrument shaft is 5 mm with a working length of 37 cm. The following controls are located on the instrument handle:

- A lever for opening and closing the instrument jaws. The mechanism incorporates a latch to hold the jaws in the closed position during vessel sealing and cutting.
- An activation button for generator power to initiate vessel sealing.
- A trigger for actuating the cutter. The cutter can only be actuated when the jaws are closed and latched.
- A rotation wheel to rotate the instrument jaws.

All controls can be operated with either the right or left hand. Vessel sealing can be initiated using the activation button or utilizing a footswitch connected to the generator. The instrument attaches to the generator via a cable with a Smart™ connector that identifies the instrument type to the generator.

Maximum rated voltage: 288 V_{peak}



Defibrillation-proof type CF applied part

Indications for Use

The Reprocessed LigaSure™ Blunt Tip Laparoscopic Sealer/Divider (Model LF1637) is a bipolar electro-surgical instrument intended for use with the Covidien electro-surgical generators that include vessel sealing capability in general and gynecologic laparoscopic surgical procedures where ligation and division of vessels and lymph is desired. The instrument creates a seal by application of RF electro-surgical energy to vascular structures (vessels and lymph) interposed between the jaws of the instrument. A blade within the instrument is surgeon actuated to divide tissue.

Indications for use include general laparoscopic procedures including urologic, vascular, thoracic and thoracoscopic, and gynecologic procedures where ligation and division of the vessels is performed. These procedures include laparoscopically assisted vaginal hysterectomy, Nissen fundoplication, colectomy, adhesiolysis, oophorectomy, etc. The device has not been shown to be effective for tubal sterilization or tubal coagulation for sterilization procedures, and should not be used for these procedures.

The Reprocessed LigaSure™ Blunt Tip Laparoscopic Sealer/Divider (Model LF1637) can be used on vessels and lymphatics up to and including 7mm, and tissue bundles.

Contraindications for Use

None

Warnings

- The LigaSure system has not been shown to be effective for tubal sterilization or tubal coagulation for sterilization procedures, and should not be used for these procedures.
- The LF1637 instrument is intended for use ONLY with the Covidien equipment listed on the cover of this document. Use of this instrument with other generators may not result in the desired tissue effect, may result in injury to the patient, or surgical team, or may cause damage to the instrument.
- These instruments are only intended for use by individuals with adequate training and familiarity with the specific procedure being undertaken. Use of this equipment without such training may result in serious unintended patient injury. For further information about techniques, complications and hazards, consult the medical literature.
- The contents of the package are provided sterile by method of ethylene oxide gas and is for single patient use only. Do not use if there is any evidence of damage to the package.
- Use the system with caution in the presence of internal or external pacemakers. Interference produced by electro-surgical equipment can cause a pacemaker to enter an asynchronous mode or can block the pacemaker effect entirely. Consult the pacemaker manufacturer or hospital cardiology department for further information when use is planned in patients with cardiac pacemakers.
- Use caution during surgical procedures in which patients exhibit certain types of vascular pathology (atherosclerosis, aneurysmal vessels, etc.). For best results, apply the seal to unaffected vasculature.

- Contact between an active instrument electrode and any metal objects (hemostats, staples, clips, retractors, etc.) may increase current flow and may result in unintended surgical effects, such as an effect at an unintended site or insufficient energy deposition.
- Confirm proper LigaSure system settings before proceeding with surgery. The default intensity setting is 2 green bars.

Adverse Reactions

None

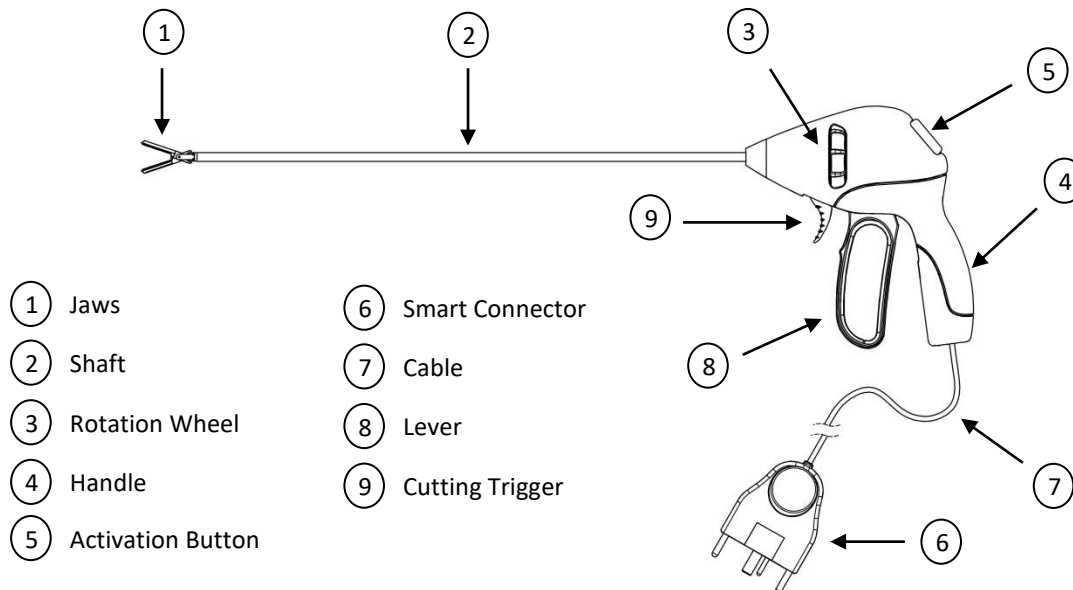

Directions for Use

1. Before beginning the procedure, verify overall compatibility of all instruments and accessories.
2. Inspect packaging before opening. The contents of the package are sterile if the package has not been compromised. Do not use the instrument if the sterility has been compromised. If the package is damaged or if it was opened and the instrument not used, return the instrument and the package to Stryker.
3. Do not attempt to resterilize. Stryker will not accept instruments for reprocessing that have been reprocessed and sterilized by other facilities.
4. Remove the instrument from the package by firmly pulling on the handle, taking care not to pull on the instrument's jaws or connector cable. Place the instrument in a sterile work area using aseptic technique.
5. Inspect the instrument for overall condition and physical integrity. Do not use the instrument if any damage is noted. Return the instrument and packaging to Stryker if it is not in acceptable condition for the procedure.
6. Follow a suitable surgery protocol.
7. The instrument is intended for use during single patient procedure.

Set Up

Warning

- **Electrical Shock Hazard** - Do not connect wet accessories to the LigaSure system.
 - Position instrument cords to avoid contact with the patient or other cords. Do not wrap cords around metal objects. This may induce currents that could lead to shocks, fires, or injury to the patient or surgical team.
 - Examine all LigaSure system and instrument connections before using. Improper connection may result in arcing, sparks, accessory malfunction, or unintended surgical effects.
 - Inspect the instrument and cords for breaks, cracks, nicks, or other damage before use. Failure to observe this caution may result in injury or electrical shock to the patient or surgical team or cause damage to the instrument. If damaged, do not use.
 - In case the instrument is accidentally dropped on the floor, turn off the generator and unplug the instrument prior to discarding.
1. Insert the Smart connector of the LF1637 into the receptacle on the generator. Follow the instructions in the generator user's guide to complete the setup procedure.

During Surgery

Tissue manipulation and Dissection

The instrument can be used to manipulate and dissect tissue with the jaws either open or closed.

Warning

- Avoid placing fingers between the lever and the handle, between the lever and the trigger, or in the jaws. Injury to the user may result.
- Use caution when handling the instrument between uses to avoid accidental activation of the LigaSure system. Do not place the instrument on the patient or drapes when not in use.
- Keep the cord free from the jaw and latch area of the instrument.
- **Fire Hazard** – Do not place instruments near or in contact with flammable materials (such as gauze, surgical drapes, or flammable gases). Instruments that are activated or hot from use may cause a fire. When not using instruments, place them in a clean, dry, highly visible area not in contact with the patient. Inadvertent contact with the patient may result in burns.
- For laparoscopic procedures, be alert to these potential hazards:
 - Do not use hybrid trocars that are comprised of both metal and plastic components. Capacitive coupling of RF current may cause unintended burns.
 - Use the appropriately sized trocar to allow for easy insertion and extraction of the instrument.
 - Carefully insert and withdraw the instrument through the cannula to avoid damage to the device and/or injury to the patient.
 - Close jaws using device lever before insertion/extraction in the trocar.

Rotating the Instrument Jaws

Do not turn the rotation wheel when the lever is latched. Product damage may occur. Turn the gray rotation wheel on the instrument until the jaws are in the required position.

Sealing Vessels and Tissue Bundles

1. Open the jaws by pushing forward on the lever.
2. Grasp the intended vessel and/or tissue in the center of the jaws.

Warning

- Do not use this instrument on vessels larger than 7 mm in diameter.
- If the instrument shaft is visibly bent, discard and replace the instrument. A bent shaft may prevent the instrument from sealing or cutting properly.
- Do not place the vessel and/or tissue in the jaw hinge. Place the vessel and/or tissue in the center of the jaws.
- Conductive fluids (e.g., blood or saline) in direct contact with, or in close proximity to, the instrument may carry electrical current or heat, which may cause unintended burns to the patient. Aspirate fluid from around the instrument jaws before activating the instrument.
- Keep the external surface of the instrument jaws away from adjacent tissue while activating the LigaSure system or unintended injury may result.
- During a seal cycle, energy is applied to the tissue between the instrument jaws. This energy may cause water to be converted into steam. The thermal energy of steam may cause unintended injury to tissues in close proximity to the jaws. Care should be taken in surgical procedures occurring in confined spaces in anticipation of this possibility.
- Eliminate tension on the tissue when sealing and cutting to ensure proper function.
- Use caution when grasping, manipulating, sealing, and dividing large tissue bundles.
- Do not bend instrument shaft.
- Do not attempt to seal or cut over clips or staples as incomplete seals will be formed.
- The surfaces of the jaws may remain hot enough to cause burns after the RF current is deactivated.
- Inadvertent activation or movement of the activated instrument outside of the field of vision may result in injury to the patient.
- Do not activate the LigaSure system in an open-circuit condition. Activate the system only when the instrument is in direct contact with the target tissue to lessen the possibility of unintended burns.
- Do not activate the instrument while instrument jaws are in contact with, or in close proximity to, other instruments including metal cannulas, as localized burns to the patient or physician may occur.
- Squeeze the lever until it latches in place.

Caution

Do not activate the LigaSure system until the lever has been latched. Activating the system before latching may result in improper sealing and may increase thermal spread to tissue outside of the surgical site.

- Relax the hand on the lever once latched. The device will maintain the latched position.

Notice – Do not apply additional hand force to the lever during sealing to ensure proper function.

- The LigaSure system can be activated by either of the following two methods:
 - Press and hold the purple activation button on the back of the instrument.
 - or*
 - By using an appropriate footswitch associated with the generator.

Note: If both the activation button and footswitch pedal are activated during the same seal cycle, the Force Triad delivers energy from the activation source it detects first.

A continuous tone sounds to indicate that the vessel or tissue is being sealed. When the seal cycle is complete, a two-pulsed end tone sounds and RF output ceases.

Notice – Keep the activation button dry and clean.

6. Release the purple activation button on the instrument, or the footswitch pedal when the seal cycle is complete.
7. To seal adjacent tissue, overlap the edge of the existing seal. The second seal should be distal to the first seal to increase seal margin.

Cutting Tissue**Warning**

Energy-based devices, such as ES pencils or ultrasonic scalpels that are associated with thermal spread, should not be used to transect seals.

Notice – Do not engage the cutting mechanism over clips, staples, or other metal objects as damage to the cutter may occur.

1. Prior to cutting the seal, inspect the vessel or tissue to ensure proper sealing.
2. To engage the cutting mechanism, pull the cutting trigger completely back toward the body of the instrument.

Important: If the cutting trigger does not automatically return to position, unlatch and open the lever to manually return the cutting trigger.

3. Open the jaws by squeezing the lever until it unlocks, then push it completely forward.

Warning

If the lever cannot be unlatched following use, open the device by forcing the lever forward from the handle. The device will no longer function properly and must be discarded.

Cleaning the Instrument During Use**Warning**

- Inspect the instrument jaws prior to cleaning to ensure the blade is not deployed.
- Do not activate the instrument or the cutting trigger while cleaning the jaws. Injury to operating room personnel may result.

Notice

- Avoid accidental activation while cleaning the instrument by placing LigaSure mode in standby. Press the standby button on the LigaSure screen to block energy delivery.
- Keep the instrument jaws clean. Build-up of eschar may reduce the seal and/or cutting effectiveness. Wipe jaw surfaces and edges with a wet gauze pad as needed.
- Do not attempt to clean the instrument jaws by activation the instrument on wet gauze. Product damage may occur.

- Do not clean the instrument jaws with a scratch pad or other abrasives.

Troubleshooting

- A pulsed tone sounds when an alert condition occurs, and the generator displays an alert message that instructs the user on the corrective actions to take.
- When an alert condition occurs, energy delivery is terminated, but will be available immediately after the alert condition has been corrected.

Check Instrument/Seal Cycle Incomplete Alert

Notice – Should an alert condition and/or incomplete-tissue-fusion-cycle alert occur, do not activate before checking the instrument as indicated below.

- A Check Instrument/Seal Cycle Incomplete alert condition produces a sequence of pulsed tones and an alert will be displayed on the generator. The user should inspect the seal site and instrument before proceeding.
- If the Check Instrument/Seal Cycle Incomplete alert appears, the user should:
 1. Release the activation button or footswitch pedal.
 2. Open the instrument jaws and inspect for a successful seal.
 3. Follow the suggested remedies displayed on the generator screen, the generator quick reference card, or in the generator user's guide.
 4. If possible, reposition the instrument and regrasp tissue in another location. Then reactivate the seal cycle.

Potential Remedies

- *Regrasp thicker tissue* – Open the jaws and confirm that a sufficient amount of tissue is inside the jaws. If necessary, increase the amount of tissue and repeat the procedure.
- *Check for clips / Regrasp tissue* – Avoid grasping objects, such as staples, clips, or encapsulated sutures, in the jaws of the instrument.
- *Clean electrode tips* – Use a wet gauze pad to clean surfaces and edges of instrument jaws.
- *Remove excess fluids* – Aspirate pooled fluids around the instrument tip.

Reactivate/Seal Cycle Incomplete Alert

- A Reactivate/Seal Cycle Incomplete alert condition produces a sequence of pulsed tones and an alert will be displayed on the generator.
- If the Reactivate/Seal Cycle Incomplete alert appears, the user should:
 1. Release the activation button or footswitch pedal.
 2. Reactivate the seal cycle without removing or repositioning the jaws from their original position.
 3. Follow the suggested corrective actions on the Seal Cycle Incomplete generator screen, the generator quick reference card, or in the generator user's guide.

Reasons:

- **Maximum seal cycle time has been reached** – The system needs more time and energy to complete the seal.
- **Seal cycle/endpoint interrupted before seal cycle was complete** – The footswitch or activation button was released before the end tone activated.
- **Inspect seal and reactivate instrument** – Follow the suggested corrective actions on the generator screen, the generator quick reference guide, or in the generator user's guide.

After Surgery

- Discard the LF1637 instrument after use according to hospital policy for biohazards and sharps.

Transport and Storage Conditions

- An ambient temperature range of -18°C to 60°C.
- Do not expose to relative humidity below 15% or above 90%.

Operating Conditions

- An ambient temperature range of +10°C to +40°C

Warranty

Reprocessed Products

Stryker warrants all reprocessed products, subject to the exceptions provided herein, to be free from defects in reprocessing and to substantially conform to the product specifications contained in the documentation provided by Stryker with the products for one use in accordance with the instructions for use of such product.

STRYKER SHALL NOT BE LIABLE FOR ANY DAMAGES TO THE EXTENT CAUSED BY ANY DEFECT IN MATERIAL, WORKMANSHIP OR DESIGN BY THE ORIGINAL MANUFACTURER OF THE PRODUCT OR ANY ACT OR OMISSION OF THE ORIGINAL MANUFACTURER OF THE PRODUCT.

Products for which Stryker is the Original Manufacturer

Stryker warrants all products for which it is the original manufacturer, subject to the exceptions provided herein, to be free from defects in design, materials and workmanship and to substantially conform to the product specifications contained in the documentation provided by Stryker with the products for a period of one year from the date of purchase.

General Warranty Terms Applicable to All Products

TO THE FULLEST EXTENT PERMITTED BY LAW, THE EXPRESS WARRANTY SET FORTH HEREIN IS THE ONLY WARRANTY APPLICABLE TO THE PRODUCTS AND IS EXPRESSLY IN LIEU OF ANY OTHER WARRANTY BY STRYKER, EXPRESSED OR IMPLIED, INCLUDING, BUT NOT LIMITED TO, ANY IMPLIED WARRANTY OR MERCHANTABILITY OR FITNESS FOR A PARTICULAR PURPOSE. IN NO EVENT WILL STRYKER'S LIABILITY ARISING IN CONNECTION WITH THE SALE OF THE PRODUCT (WHETHER UNDER THE THEORIES OF BREACH OF CONTRACT, TORT, MISREPRESENTATION, FRAUD, WARRANTY, NEGLIGENCE, STRICT LIABILITY OR ANY OTHER THEORY OF LAW) EXCEED THE PURCHASE PRICE, CURRENT MARKET VALUE OR RESIDUAL VALUE OF THE PRODUCTS, WHICHEVER IS LESS. STRYKER SHALL NOT BE LIABLE FOR INDIRECT, SPECIAL, INCIDENTAL, PUNITIVE OR CONSEQUENTIAL DAMAGES RESULTING FROM ANY BREACH OF WARRANTY OR UNDER ANY OTHER LEGAL THEORY.

This warranty shall apply only to the original end-user purchaser of products directly from Stryker or a Stryker authorized distributor. This warranty may not be transferred or assigned without the express written consent of Stryker.

This warranty does not apply to: (1) products that have been misused, neglected, modified, altered, adjusted, tampered with, improperly installed or refurbished; (2) products that have been repaired by any person other than Stryker personnel without the prior written consent of Stryker; (3) products that have been subjected to unusual stress or have not been maintained in accordance with the instructions in the user manual or as demonstrated by a Stryker representative; (4) products on which any original serial numbers or other identification marks have been removed or destroyed; or (5) products that have been repaired with any unauthorized or non-Stryker components.

If a valid warranty claim is received within thirty (30) days of the expiration of the applicable warranty period, Stryker will, in its sole discretion: (1) replace the product at no charge with a product that is at least functionally equivalent to the original product or (2) refund the purchase price of the product. If a refund is provided by Stryker, the product for which the refund is provided must be returned to Stryker and will become Stryker's property. In any event, Stryker's liability for breach of warranty shall be limited to the replacement value of the defective or non-conforming part or component.

If Stryker determines in its reasonable discretion that the claimed defect or non-conformance in the product is excluded from warranty coverage as described hereunder, it will notify the customer of such determination and will provide an estimate of the cost of repair of the product. In such an event, any repair would be performed at Stryker's standard rates.

Products and product components repaired or replaced under this warranty continue to be warranted as described herein during the initial applicable warranty period or, if the initial warranty period has expired by the time the product is repaired or replaced, for thirty (30) days after delivery of the repaired or replaced product. When a product or component is replaced, the item provided in replacement will be the customer's property and the replaced item will be Stryker's property. If a refund is provided by Stryker, the product for which the refund is provided must be returned to Stryker and will become Stryker's property.

The OEM information listed on the label is provided as device ID prior to reprocessing and may contain the trademarks of unrelated third parties that do not sponsor this device.

Sterilization: This product and its packaging have been sterilized with ethylene oxide gas (EtO). Even though the product then is processed in compliance with all applicable laws and regulations relating to EtO exposure, Proposition 65, a State of California voter initiative, requires the following notice:

Warning: This product and its packaging have been sterilized with ethylene oxide. The packaging may expose you to ethylene oxide, a chemical known to the State of California to cause cancer or birth defects or other reproductive harm.

Covidien™ is a registered trademark of Covidien AG.
ForceTriad™ and LigaSure™ are trademarks of a Covidien company.

VSD EL10029 Rev. G 08/2018 RM702135