

stryker

12F **Steerable** **introducer sheath**

Instructions for use
(English Only)

SYMBOLS GLOSSARY

(Symbol and SDO reference provided where applicable.)



Manufacturer

(ISO 15223-1 Medical devices - Symbols to be used with medical device labels, labelling and information to be supplied §5.1.1)



Date of manufacture

(ISO 15223-1 Medical devices - Symbols to be used with medical device labels, labelling and information to be supplied §5.1.3)



Distributor

(N/A)



Use-by date

(ISO 15223-1 Medical devices - Symbols to be used with medical device labels, labelling and information to be supplied §5.1.4)



Batch code

(ISO 15223-1 Medical devices - Symbols to be used with medical device labels, labelling and information to be supplied §5.1.5)



Catalog number

(ISO 15223-1 Medical devices - Symbols to be used with medical device labels, labelling and information to be supplied §5.1.6)



Sterilized using ethylene oxide

(ISO 15223-1 Medical devices - Symbols to be used with medical device labels, labelling and information to be supplied §5.2.3)



Do not resterilize

(ISO 15223-1 Medical devices - Symbols to be used with medical device labels, labelling and information to be supplied §5.2.6)



Do not re-use

(ISO 15223-1 Medical devices - Symbols to be used with medical device labels, labelling and information to be supplied §5.4.2)



Do not use if package is damaged

(ISO 15223-1 Medical devices - Symbols to be used with medical device labels, labelling and information to be supplied §5.2.8)



Keep away from sunlight

(ISO 15223-1 Medical devices - Symbols to be used with medical device labels, labelling and information to be supplied §5.3.2)



IFU at sustainability.stryker.com/ifu

Consult Instructions for use

(ISO 15223-1 Medical devices - Symbols to be used with medical device labels, labelling and information to be supplied §5.4.3)



Keep dry

(ISO 15223-1 Medical devices - Symbols to be used with medical device labels, labelling and information to be supplied §5.3.4)



By prescription only

(21 CFR 801.109, Labeling - Prescription devices)



Caution

(ISO 15223-1 Medical devices - Symbols to be used with medical device labels, labelling and information to be supplied §5.4.4)



Non-pyrogenic

(ISO 15223-1 Medical devices - Symbols to be used with medical device labels, labelling and information to be supplied §5.6.3)

12F

Steerable introducer sheath

Instructions for use

English



CAUTION: Federal law (U.S.) restricts this device to sale by or on the order of a physician.



CAUTION: The device is provided sterile (ethylene oxide) for single use only.

Package contents

One (1) Steerable introducer sheath, dilator, and guidewire.

Storage

Store at room temperature in a dark, dry place to avoid extended exposure to light and moisture.

Device description

The Steerable introducer sheath consists of a steerable sheath connected to a handle with steering controls, a hemostasis valve with sideport featuring a 3-way stopcock, and a tapered dilator. The device is provided sterile in a sealed tyvek pouch and carton with IFU. The sheath distal tip and dilator shaft are radiopaque for visualization under fluoroscopy. The dilator is designed to accommodate a guidewire, with size compatibility as indicated on the product labels. A dilator hub is provided with a female luer tapered fitting for flushing (see illustration below). The device includes a side port with stopcock to allow fluid injection and sampling, drip infusion, pressure monitoring, flushing and aspiration.

The device usable length, lumen length, outer diameter, curl size, and inner diameter/tool compatibility specifications are indicated on the product labels (see illustration page 4). The distal end of the sheath features 180° bi-directional deflection to provide directional control to the compatible tools interacting with the device.

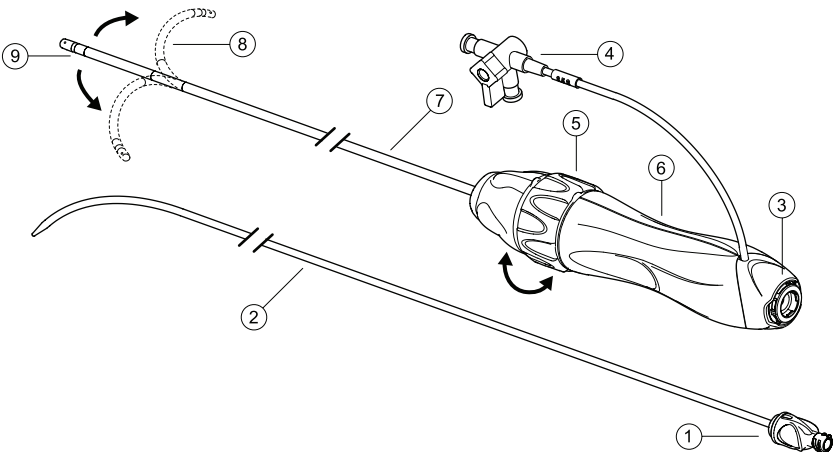

- | | | |
|---------------------|---------------------|----------------------|
| 1. Dilator hub | 4. 3-way stopcock | 7. Introducer sheath |
| 2. Dilator | 5. Steering control | 8. Steerable section |
| 3. Hemostatic valve | 6. Handle | 9. Radiopaque marker |

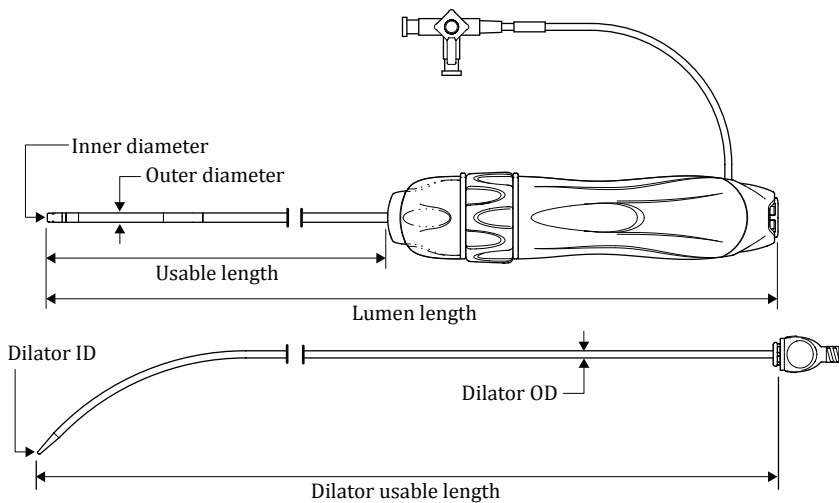

Indications for use

The 12F Steerable introducer sheath is intended for percutaneous catheter introduction into the vasculature and into the chambers of the heart. The sheath deflection facilitates catheter positioning.

Contraindications

The 12F Steerable introducer sheath is contraindicated for placement in the left atrium or ventricle if the following conditions apply:

- Previous intra-atrial septal patch or surgical intervention adjacent to the septum
- Known or suspected atrial myxoma
- Myocardial infarctions within two weeks prior to procedure
- The patient has had a previous embolic event from the left side of the heart within two months of the procedure
- Unstable angina
- Recent cerebral vascular accident (CVA)
- Patients who do not tolerate anticoagulation therapy
- Patients with active infection
- Presence of atrial thrombus

The 12F Steerable introducer sheath should not be used to perform the trans-septal puncture.

Warnings and precautions



CAUTION: Read all instructions carefully. Failure to properly follow instructions, warnings, and precautions may lead to complications and injury to the patient.

- Provided sterile (ethylene oxide) for single use only. Do not reuse or re-sterilize this product. Reuse or re-sterilization may compromise the functional integrity of the product or create risk of contamination, which could result in patient injury, illness or death.
- This product should only be used by or under the supervision of physicians trained in cardiac catheterization procedures in a fully equipped facility.
- Carefully inspect the sheath, packaging, and labels for damage or defects prior to use.
- If the Use-by date has elapsed, the device is damaged or the sterile barrier has been compromised, do not use.
- Do not alter, cut, puncture, and/or modify this device.
- The French size specified represents the inner diameter of the steerable introducer sheath.
- Suitable patient anatomy is required to safely introduce the sheath into the vasculature. Confirm appropriate vessel size, anatomy, tortuosity, presence of vessel disease and condition of the access site prior to insertion for successful introduction and use.

- Verify sheath, device, and accessory sizes for compatibility prior to use. Do not attempt to insert a diagnostic or therapeutic tool larger than the indicated French size into the device.
- The Steerable introducer sheath interlocks ONLY with the dilator provided. Misuse or use of other dilators may result in serious complications. Prior to inserting into the patient, pre-assemble the dilator into the device and confirm interlock.
- Reference the product labels for guidewire compatibility.
- Do not advance without a guidewire; maintain guidewire position at all times.
- For best results, ensure that the introducer sheath remains wetted during placement.
- Insertion may cause excessive bleeding, air embolism, or other complications.
- During insertion do not create excessive bends in the device.
- Frequently aspirate and flush sheath with saline to minimize the potential for thrombus formation.
- Aspiration should only be conducted without an auxiliary device inserted. Aspirate slowly from the sideport until all air has been removed from the device. Proper device preparation minimizes the risk of air emboli (see Page 7).
- Inject or saline flush only from the sideport.
- Only advance and retract the introducer under fluoroscopic guidance with the dilator securely locked into place.
- Do not attempt to insert or withdraw the introducer sheath or dilator if resistance is felt. Determine the cause of resistance and address before proceeding.
- Remove dilator slowly to minimize vacuum and damage to hemostasis valve.
- It is recommended to minimize the number of catheter exchanges to minimize the risk of complications, including air emboli. Follow advancement and removal of catheters with appropriate aspiration and flushing.
- Indwelling percutaneous introducers should always be supported with a dilator or tool.
- Certain conditions may require special attention when using this product. These may be, but are not limited to: Enlarged Aortic Root, Small Left Atrium, Marked Right Atrial Enlargement, Marked Distortion of the Thorax Configuration (i.e. Kyphosis or Scoliosis).
- The use of fluoroscopy during sheath manipulation and placement is strongly advised. Manipulation of the sheath without fluoroscopy may result in damage to cardiac and/or vascular tissues.
- The use of fluoroscopy during device use presents the potential for significant radiation exposure to the patient and user. Extensive exposure can result in acute radiation injury and increased risk of somatic and genetic effects. Adequate attention should be given to fluoroscopy use to minimize exposure and risk. Give careful consideration before using this device in pregnant women.
- Regular flushing or saline drip over the duration of the procedure is recommended to minimize risk of blood stagnation, clotting, emboli, backbleeding, contrast accumulation within the lumen and serious patient injury.
- If a saline drip is not utilized make sure the stopcock is in the closed position after aspiration and flushing.
- Use extreme care when handling, manipulating, and steering the device. Lack of attention can result in perforation, tamponade, induction of arrhythmia or heart block.
- Avoid positioning the device around the chordae tendineae as this increases the likelihood of device entrapment, which may necessitate surgical intervention.
- Do not pass the device through a prosthetic heart valve (mechanical or tissue). The device may become entrapped, damage the valve and cause insufficiency, migration, or premature failure of the valve.
- Upon removal of the sheath, precautions should be taken to prevent bleeding, vessel damage or other serious injury.
- After use, dispose of the sheath in accordance with hospital policies.
- This device has not been tested for MRI compatibility.
- Store in a cool, dark, dry place.

Clinical use information

- This product should only be used by or under the supervision of physicians trained in cardiac catheterization procedures in a fully equipped facility.
- If the Use-by date has elapsed, the sheath, dilator or guidewire are damaged, or the sterile pouch barrier has been compromised, do not use the product. Contact Stryker Sustainability Solutions for return or replacement.
- Standard techniques for placement of vascular introducer sheaths should be employed.
- Based on patient conditions, pre-dilation may be required.

Potential adverse events

Adverse events that may occur and/or require intervention include but are not limited to:

- Air embolism
- Allergic response to materials, including contrast media
- Arrhythmia (atrial fibrillation, atrial flutter, tachycardia)
- Arteriovenous fistula formation
- Atrial septal defect
- Blood loss (hemorrhage, hemothorax, etc.)
- Cardiac arrest
- Catheter entrapment within anatomy
- Chest discomfort, pain or pressure
- Coronary artery spasm, dissection, or thrombosis
- Death
- Dislodgement
- Ecchymosis
- Endocarditis
- Heart block/bradycardia
- Hematoma
- Infection
- Irregular heart beat
- Local nerve damage
- Mediastinal widening
- Myocardial infarction
- Pacemaker/defibrillator lead displacement
- Pericardial pleural effusion
- Pericardial tamponade
- Pericarditis
- Pneumothorax
- Pseudoaneurysm formation
- Pulmonary edema
- Pulmonary embolism
- Septal dissection
- Stroke
- Thromboembolic events (micro or macro) with transient or permanent ischemia
- Thrombophlebitis
- Transient ischemic attack (TIA)
- Valve damage
- Vascular occlusion
- Vasovagal reaction
- Vascular trauma (e.g. dissection, rupture, perforation or tear)

Additional recommended equipment

- 20cc or greater syringe
- Heparinized saline solution

Suggested instructions for use

Site preparation

Follow typical sterile accepted practice for initial access to vessel lumen (e.g. Seldinger Technique) and placement of a compatible guidewire. Pre-dilation may be required prior to introduction of the device.

Device preparation

1. The steerable introducer is supplied sterile in a tray contained within a pouch with the contents listed on the pouch and box labels. Remove the contents from the packaging following typical aseptic handling procedures for the sterile pouch contents.
2. Inspect the device, dilator, and guidewire for any signs of damage, paying special attention during inspection to the device tip.
3. Confirm device steering functionality by rotating the steering knob clockwise and counterclockwise to observe deflection of the distal tip and become familiar with the steering response and directional controls. Return the tip position to neutral.
4. Elevate the device distal tip and flush the steerable sheath using a syringe containing sterile heparinized saline connected to the sideport. Close the 3-way stopcock before removing the syringe.
5. Flush the dilator lumen using a syringe containing sterile heparinized saline connected to the luer fitting provided on the dilator hub.

Note: It is recommended to maintain attachment of the syringe to the dilator hub to prevent air ingress into the lumen.

6. It is recommended to wet the dilator shaft with sterile saline prior to insertion into the steerable introducer sheath to minimize friction.
7. Insert the dilator into the steerable introducer sheath and lock the dilator hub to the handle by pressing the hub to the valve cap resulting in a tactile and auditory 'snap.' Remove the syringe from the dilator hub.
8. Immediately prior to insertion, wipe the steerable introducer shaft with sterile saline to ease insertion into the anatomy.

Steerable sheath insertion

9. Verify the Steerable introducer sheath is in the neutral position and insert the guidewire into the distal end of the dilator, advancing the device over the wire to the access site.
10. Using standard introducer insertion techniques advance the steerable introducer sheath over the wire to the desired location under fluoroscopic guidance. If resistance is encountered determine the cause and correct before continuing the procedure.
11. To minimize embolic risk, attach a pressurized heparinized saline flush (drip) to the sideport, or periodically aspirate and flush the sheath throughout the procedure. Aspiration should only be conducted without an auxiliary device inserted.
12. After obtaining access administer anticoagulation therapy throughout the duration of the procedure in accordance with institutional standards.

Interventional use and steering

13. When dilator removal is required per steps associated with the therapy, maintain position of both the Steerable introducer sheath and guidewire and unlock the dilator by pivoting the dilator hub off axis followed by slow withdrawal of the dilator and guidewire as a unit, followed by aspiration of the device, taking precautions to prevent air ingress.
14. The steerable introducer is ready for introduction and exchanges of compatible interventional tools. Follow the specific manufacturer's instructions for use, recommendations, and precautions for the interventional tool being used.

15. Advance the compatible interventional tool through the hemostatic valve, through and beyond the distal tip of the steerable sheath, as appropriate for the working space within the anatomy. It is recommended to confirm distal position of the devices with fluoroscopic imaging, or whenever steering or manipulation of the device is being affected by the user.

Note: Insert and withdraw compatible tools slowly to minimize creation of vacuum. The steerable introducer sheath can be flushed while a compatible tool is inserted.

16. Deflection and guidance of the distal tip of the device is achieved by rotating the steering knob of the handle. Deflection plane orientation is in plane with the sideport. It is recommended that the compatible interventional tool extend beyond the distal end of the steerable introducer sheath prior to deflection.



CAUTION: Any rigid section(s) of the interventional tool MUST NOT be positioned within the deflectable section of the steerable introducer sheath while deflecting to avoid risk of damage and loss of control.



CAUTION: Do not deflect the steerable introducer sheath beyond 180° while inserting a compatible tool. If resistance is encountered advancing the tool it may be necessary to relax the steering angle to pass the tool through the curve.

17. Rotational control of the device may be achieved by the user rotating the handle to the desired orientation. Prior to rotation the user should be conscious of the anatomical working space to prevent patient injury. It is recommended to confirm orientation of the device with fluoroscopic imaging prior to and during manipulation.

Device removal

18. At the completion of the procedure, with interventional tool(s) removed, confirm the distal tip of the Steerable introducer sheath is in the neutral (undeflected) position.
19. Extract the device from the vessel and maintain hemostasis.

Product complaints

Any complaints involving the Steerable introducer sheath should be reported immediately to Stryker Sustainability Solutions and to the national and regional registries for cardiovascular interventions. To report a complaint in the US, call 888.888.3433. Outside the US contact your local distributor or representative.

Limited warranty and disclaimer

Freudenberg Medical, LLC (FM) is the manufacturer of this product and hereby warrants to the Customer that its products are free from defect in design, workmanship and materials under normal use and service. If any FM manufactured product fails to perform within normal tolerances for a patient due to a defect in materials or workmanship, an equivalent replacement product shall be provided at no charge for the patient's use. FM further warrants that sterilized products shall remain sterile to the expiration date provided on the product label(s), provided that the original packaging remains intact and is not compromised in any manner. This warranty does not apply to products that have been re-sterilized, reused or reprocessed, repaired, or altered in any manner, or to products that have been improperly stored, installed, operated, or maintained in any manner. This limited warranty applies only if each of the following conditions are met:

1. The product was packaged and labeled by FM.
2. The failed product must be returned to, and becomes the property of, FM.
3. The product has not been mishandled, reprocessed or altered in any way.
4. The product was used before the "USE BY" date marked on the product label(s).

No representation or warranty is made that a FM product will not fail. Except as expressly indicated above, the Customer assumes all responsibility and all other liability, whether based upon warranty, contract, negligence, or otherwise, for injury or damages resulting from handling, possession, use or misuse of any FM product and agrees to defend and indemnify FM of same. FM disclaims responsibility for any medical complications, including death, resulting from the use of its products. FM SHALL NOT BE LIABLE TO ANY PERSON OR ENTITY FOR ANY MEDICAL EXPENSES OR ANY DIRECT, INCIDENTAL, OR CONSEQUENTIAL DAMAGES CAUSED BY ANY USE, DEFECT, FAILURE, OR MALFUNCTION OF THE PRODUCT, WHETHER A CLAIM FOR SUCH DAMAGES IS BASED UPON WARRANTY, CONTRACT, TORT, OR OTHERWISE. FM DISCLAIMS ALL LIABILITY WITH RESPECT TO PAIN AND SUFFERING, LOST INCOME, LOSS OF EARNING POTENTIAL, MEDICAL EXPENSES, AND ALL OTHER DAMAGES RELATED TO OR ARISING FROM THE DESIGN, MANUFACTURE, OR USE OF THIS PRODUCT. NO PERSON HAS ANY AUTHORITY TO VARY OR EXTEND THIS LIMITED WARRANTY OR BIND FM TO ANY REPRESENTATION WITH RESPECT TO THE PRODUCT. The exclusions and limitations set out above are not intended to, and should not be construed so as to, contravene mandatory provisions of applicable law. If any part or term of this disclaimer of warranty is held to be illegal, unenforceable, or in conflict with applicable law by a court of competent jurisdiction, the validity of the remaining portions of this disclaimer of warranty shall not be affected, and all rights and obligations shall be construed and enforced as if this disclaimer of warranty did not contain the particular part or term held to be invalid. OTHER THAN THE CONDITIONAL, LIMITED WARRANTY EXPRESSLY SET FORTH ABOVE, FM MAKES NO WARRANTY, EXPRESS OR IMPLIED, INCLUDING, BUT NOT LIMITED TO, ANY IMPLIED WARRANTY OF MERCHANTABILITY, OR FITNESS FOR A PARTICULAR PURPOSE.

State of California (USA only)



WARNING: This product and its packaging have been sterilized with ethylene oxide. The packaging may expose you to ethylene oxide, a chemical known to the State of California to cause cancer or birth defects or other reproductive harm.

For more information go to www.P65Warnings.ca.gov

stryker



Distributed by:

Stryker Sustainability Solutions
1810 West Drake Drive
Tempe, AZ 85283-4327
888 888 3433
+1 480 763 5300

sustainability.stryker.com



Manufactured by:

Freudenberg Medical, LLC
2301 Centennial Blvd
Jeffersonville, IN 47130 USA

www.freudenbergmedical.com

SIS EL10123 Rev. A 06/2020

AW1005144 Rev A

2020-05-28

©2020 Freudenberg Medical, LLC

All rights reserved.

See www.freudenbergmedical.com/patents for US and international patents.