



entellus
MEDICAL®

FocESS™
Sinuscope

INSTRUCTIONS FOR USE

FocESS™ Sinuscope

Instructions for Use

Table of contents

1.	About this document	1
1.1	Purpose.....	1
1.2	Symbols used.....	1
2.	Intended use	2
3.	Safety information	2
4.	Testing, handling and maintenance	3
5.	Description	3
5.1	Construction	3
5.2	Markings.....	3
5.3	Available designs and sizes	3
5.4	Combinable products	3
6.	Preparation for use.....	4
6.1	Visual inspection and function check	4
6.2	Provisioning.....	4
7.	Use.....	5
8.	Processing	5
8.1	Safe storage and transport.....	5
8.2	Cleaning and disinfection	5
	Manual cleaning / pre-cleaning and chemical disinfection	5
	Machine cleaning and thermal disinfection	6
	Removing deposits from optical end surfaces.....	7
8.3	Sterilization.....	7
	Steam sterilization (autoclaving)	7
	Fractionated pre-vacuum method	7
	Gravitation method.....	8
	Hydrogen peroxide sterilization (STERRAD® method)	8
	Ethylene oxide sterilization.....	8
8.4	Special precautions: Pathogens of Transmissible Spongiform Encephalopathy	8
8.5	Processing restrictions	8
9.	Assembly.....	9
10.	Disassembly.....	10
11.	Storage.....	10
12.	Service and maintenance.....	10
13.	Accessories / spare parts.....	11
14.	Disposal	11
15.	Symbols	11

1. About this document

1.1 Purpose

This document describes the correct handling and function of the rigid endoscope, as well as recommended processing methods.





This document may not be used to carry out endoscopic examinations or surgeries, nor may it be used for training purposes.

The respective current version of this document can be requested from Entellus Medical.

If you as the user of this endoscope believe that you require more detailed information regarding the product's use and maintenance, please contact your representative.

1.2 Symbols used

The following symbols are used in this document to make it easier for you to access the information:

	Instructions for preventing personal injury
	Instructions for preventing material damage
	Information to facilitate understanding or workflow optimization
	Prerequisite
	Instruction

2. Intended use

The FocESS™ Sinuscope is intended to provide the physician with a means for endoscopic diagnostic and therapeutic sinus surgical procedures.

The Sinuscope is indicated for use in, but not limited to such procedures as examination of sinus passages and cavities, removal of abnormal growths such as polyps and facio-plastic surgery.

3. Safety information

The endoscope may only be used by trained medical professionals in medical facilities.

- After delivery, inspect the endoscope for completeness and damage.
- Read, observe and keep the instructions for use.
- Use the endoscope only as intended, see “Intended use” on page 2.

For storage, transport and processing, ensure that the endoscope is not subjected to mechanical strain, particularly to prevent damage to the sensitive lens system.



WARNING

Risk of infection to the patient or medical professionals!

The endoscopes are delivered non-sterile as reusable products.

The state of the art and national laws require the observance of validated processes.

In general, users are responsible for the validation of their processes.

- **Ensure that the processing, material and personnel are suitable for achieving the results necessary.**
- **Observe any valid local operator regulations for all manual cleaning and drying processes.**
- **Clean / disinfect and sterilize the endoscope prior to initial use as well as each subsequent use of the endoscope.**
- **Bring the endoscope to the decontamination area after use. Observe valid protective measures to prevent contaminating the environment.**



WARNING

Risk of burns!

The optical fibers emit high-energy light at the distal end of the endoscope. This can cause the temperature of the body tissue to rise to 41 °C.

- **Avoid direct contact of the distal end with body tissue or flammable materials as it can cause burns.**
- **Reduce the light intensity of the cold light source when working near body tissue or flammable materials.**



WARNING

Risk of injury due to faulty endoscopes!

- **Carry out visual inspection and function check prior to each use.**
- **Only use endoscopes which are in perfect condition.**

4. Testing, handling and maintenance

Endoscopes from Entellus Medical are precision medical instruments, and handling them requires great care.

- Inspect the endoscope for damage prior to and after use.
- If the endoscope is damaged, discontinue use and contact the manufacturer.
- Do not subject the endoscope to impact.
- Put the endoscope down carefully.
- Hold endoscope only by the ocular funnel / main part and not by the sheath.
- Do not bend the sheath.
- Do not bend the body after inserting the endoscope into the body. A piece broken off the endoscope can become lodged in the soft tissue or no longer appear in the endoscope's field of vision and thus remain in the body.
- Transport endoscopes individually and store them safely by using a screen basket or container.

5. Description

5.1 Construction

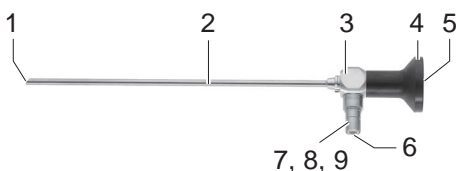

- 1 Distal end
- 2 Sheath
- 3 Main part
- 4 Ocular funnel
- 5 Proximal end
- 6 Irradiation surface of the illumination fibers
- 7 Connection for illumination fiber, type ACMI
- 8 Adapter for illumination fiber, type Wolf, pre-assembled
- 9 Adapter for illumination fiber, type Storz / Olympus (assembly, see "Assembly" on page 9.)

5.2 Markings

- Serial number
- For autoclavable endoscopes: Writing "autoclavable"
- Specification of the direction of view
- Writing GERMANY
- Writing ENTELLUS MEDICAL

5.3 Available designs and sizes

The endoscopes are available in the following designs and sizes:

- Straight endoscopes with 0°, 30°, 45° and 70° viewing angles
- Sheath diameter of 3 mm

5.4 Combinable products

You can combine the endoscopes with existing camera systems and with illumination fibers and instruments.

6. Preparation for use

6.1 Visual inspection and function check



WARNING

Risk of injury due to faulty endoscopes!

- Carry out a visual inspection and function check prior to initial use as well as each additional use.
- Only use endoscopes which are in perfect condition.
- Clean / disinfect and sterilize the endoscope prior to initial use as well as each additional use of the endoscope. Contaminants on the irradiation surface of the illumination fibers can burn in during use, which impacts image quality.
- Ensure that the proximal end of the endoscope is dry to prevent the endoscope from fogging up during the examination / procedure.
- Ensure that no parts are missing or loose.
- Ensure that there are no residual cleaning agents or disinfectants on the endoscope.
- Inspect the entire endoscope, particularly the sheath, for contaminants and damage of any type, such as dents, scratches, cracks, bending and sharp edges.
- Inspect distal end, proximal end and irradiation surface of the illumination fibers for contamination and scratches. Make contaminants and scratches visible using light reflexes. Hold the connection of the optical fibers against the light and inspect whether the optical fibers illuminate evenly at the distal end.
- Check image quality: The image may not be blurry, clouded or dark. If necessary, remove deposits on the optical end surface using polishing paste provided, see “Removing deposits from optical end surfaces” on page 7.
- For endoscopes with locking device: Inspect between the sheath and the main part for contaminants and damage to ensure a fixed and secure connection.

6.2 Provisioning

- Clean / disinfect and sterilize the endoscope prior to initial use as well as each additional use of the endoscope, see “Processing” on page 5.
- Ensure that the proximal end of the endoscope is dry to prevent the endoscope from fogging up during the examination/ procedure.
- If necessary mount adapter for illumination fiber, see “Assembly” on page 9.
- Mount illumination fiber (see manufacturer's specifications).
- If required, adapt the camera (see manufacturer's specifications).

7. Use



WARNING

Risk of burns!

The optical fibers emit high-energy light at the distal end of the endoscope. This can cause the temperature of the body tissue to rise to 41 °C.

- Avoid direct contact of the distal end with body tissue or flammable materials as it can cause burns.
- Reduce the light intensity of the cold light source when working near body tissue or flammable materials.

- Prepare the endoscope for processing immediately after use to prevent surface drying of the contaminants.

8. Processing

8.1 Safe storage and transport

If possible, reprocessing endoscopes immediately after use is recommended. Endoscope containers and trays are reusable. Trays must be inspected for visible contamination and cleaned prior to use. They can be cleaned manually or in an automatic cleaning unit using a cleaning agent.

- Always store endoscope securely and transport it to processing in a closed container to prevent damage to the endoscope and contamination of the environment.

8.2 Cleaning and disinfection

Manual cleaning / pre-cleaning and chemical disinfection



- Do not use fixating cleaning agents or hot water (>40 °C) as it can cause fixation of the contaminants and jeopardize successful cleaning.
- Do not scratch contaminants off with hard objects as this can cause damage to the optical end surfaces.
- Do not clean endoscope in an ultrasonic bath.

- ✓ Existing adapters are dismantled.

- Remove coarse contamination from the endoscope. Clean the endoscope with a soft brush under cold tap water until all visible contaminants have been removed.
- For holes and threads: Rinse with a water pistol for at least 10 seconds at a pressure of at least 3.8 bar (absolute).



The endoscopes have material compatibility with the Steris™ System 1 process.

- Disinfect endoscope. In doing so, observe the specifications of the disinfectant solution manufacturer regarding temperature, concentration and application time.



Non-compliance with the manufacturer's specifications can result in damage to the endoscope.

- Rinse endoscope with running water.
- Dry endoscope with a soft cloth.
- Carry out visual inspection, function check and servicing, see "Testing, handling and maintenance" on page 3.

Machine cleaning and thermal disinfection

The FocESS™ Sinusscopes are suitable for prevalent machine methods of cleaning and thermal disinfection. In doing so, use gentle cycles for rigid endoscopes and suitable cleaning agents and disinfectants. The instructions of the machine, cleaning agent and disinfectant manufacturers must be observed. The cleaning and disinfectant result must be confirmed by the machine, cleaning agent and disinfectant manufacturers in cooperation with the user.

The following methods have been validated for the endoscopes:

- Fix the endoscope to the loading rack in such a way that damage is prevented during cleaning.

The following materials and machines were used for the validation:

- Cleaning agent:
 - Alkaline: Neodisher FA; Dr. Weigert; Hamburg
 - Enzymatic: Endozime, Ruhof
- Neutralizer:
 - Neodisher Z; Dr. Weigert, Hamburg
- Cleaning and disinfecting unit:
 - Miele G 7736 CD
- Loading rack:
 - Loading rack E 327-06
 - MIC rack E 450
- Start cleaning process:
 - Pre-rinse with cold water for 1 minute
 - Drain
 - Pre-rinse with cold water for 3 minutes
 - Drain
 - Clean with 0.5% alkaline cleaning agent for 5 minutes at 55 °C or with 0.5% enzymatic cleaning agent at 45 °C
 - Drain
 - Neutralize for 3 minutes with warm tap water (<40 °C) and neutralizer
 - Drain
 - Intermediate rinse for 2 minutes with warm tap water (<40 °C)
 - Drain
- Carry out machine thermal disinfection considering the national requirements regarding the A₀ value (see DIN EN ISO 15883).
- Ensure that the exteriors of the endoscope are dry. If necessary, dry with a soft cloth.
- Carry out visual inspection, function check and servicing, see “Testing, handling and maintenance” on page 3.

Removing deposits from optical end surfaces

If deposits are found when checking the image quality, they can be removed with the provided polishing paste as follows:

i ➤ **Only clean with polishing paste if the image which you see through the endoscope is cloudy and blurry.**

- Apply polishing paste to a clean cotton swab.
- For large end surfaces: press cotton swab lightly on the end surface to be cleaned and rub it over the glass.
- For small end surfaces: place cotton swab lightly on the end surface to be cleaned and turn it.

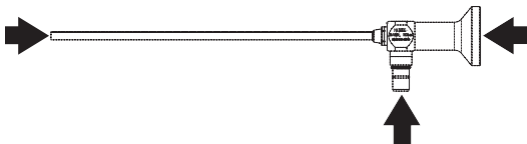

- Clean all optical end surfaces with warm water and mild detergent to remove all polishing paste residue.
- Rinse optical end surfaces under running water.
- Dry optical end surfaces with a soft cloth.
- Clean / disinfect and sterilize the endoscope.
- Carry out visual inspection. If the deposits were not removed: send in endoscope for repair.

8.3 Sterilization

i **Prior to each sterilization, rigid endoscopes must be cleaned and disinfected according to the methods in these instructions for use.**

- Sterilize endoscopes in suitable packaging to prevent subsequent contamination.

Steam sterilization (autoclaving)

In general, users are responsible for the validation of their processes.



Only endoscopes which are marked with the writing "autoclavable" are intended for autoclaving. The permissible processing methods are explained in the instructions at hand.

- When selecting the processing method, observe the valid national hygienic regulations and local provisions for hospital hygiene.



Comply with specified process parameters. The specified parameters have been validated to ensure the sterility of the endoscopes. Deviating process parameters could damage the endoscope. In this case, the guarantee and warranty shall become void.



Autoclavable endoscopes can be sterilized with the French cycle (134 C, 18 minutes, 3.1 bar (absolute) without restrictions regarding material compatibility.

- ✓ Existing adapters are dismantled.
- Sterilize endoscopes.
- When the sterilization process has ended, allow the endoscopes to cool gradually to room temperature.

Fractionated pre-vacuum method

The following process has been validated:

Temperature	132–137 °C (270–278 °F)
Time	At least 3 minutes
Configuration	Double packed in sterilization bags
Drying	At least 10 minutes

Gravitation method

- i** The endoscopes have material compatibility with the gravitation method for a hold time of 15 minutes.

Hydrogen peroxide sterilization (STERRAD® method)

Endoscopes can be sterilized with the following STERRAD systems:

- STERRAD 100S
 - STERRAD NX
 - STERRAD 100NX
- Observe specifications of the manufacturer (ASP) regarding the corresponding method.

Ethylene oxide sterilization

- i** The endoscopes are material compatible with ethylene oxide sterilization.

8.4 Special precautions: Pathogens of Transmissible Spongiform Encephalopathy

A comprehensive explanation of the necessary preventative measures with regard to agents of Transmissible Spongiform Encephalopathy (TSE) would go beyond the scope of this document.

It is assumed that pathogens of the Creutzfeldt Jakob Disease cannot be killed using normal disinfection and sterilization processes. Therefore, the standard methods for decontamination and sterilization are not sufficient if there is a risk of transferring Creutzfeldt Jakob Disease.

In general, only tissue with a low potential of TSE infection comes into contact with surgical instruments. In spite of this, special preventative measures must be taken for instruments which are used to treat patients with a known or suspected infection of TSE, as well as for patients at risk.

8.5 Processing restrictions

Repeated processing has only minimal effect on the endoscopes. The service life of the units is usually determined by wear and damage.

The endoscope can be damaged if the manufacturer's specifications are not observed.



- **Do not clean endoscope in an ultrasonic bath.**

9. Assembly

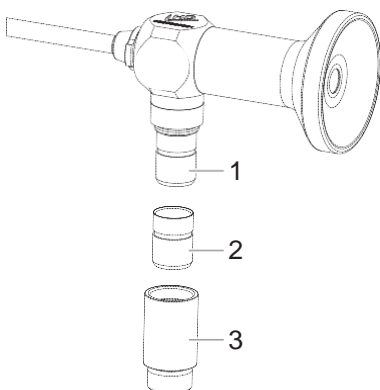

- 1 Connection for illumination fiber, type ACMI
- 2 Adapter type Wolf
- 3 Adapter type Storz / Olympus

- If necessary mount adapter for illumination fiber
- Ensure that the irradiation surface of the illumination fiber is clean.
- Mount illumination fiber (see manufacturer's specifications).
- If required, adapt the camera (see manufacturer's specifications).

10. Disassembly



WARNING

Risk of burns!

Allow the illumination fiber to cool sufficiently before removing it. The ends can become very hot and cause serious burns.

➤ **Remove illumination fiber.**



➤ **Do not remove the ocular funnel because otherwise the endoscope will be damaged.**

➤ Unscrew existing adapters.

11. Storage

Unsterile metal units must be stored in a clean, dry environment. The storage time of unsterile units is not limited; the units are made of a non-degradable material which maintains its stability when stored under the recommended conditions.

As long as endoscopes are stored unsterile in the original packaging, the following storage conditions apply:

– Temperature: –10 °C to +40 °C

– Humidity: 10% to 90%

➤ Avoid direct sunlight.

➤ Store endoscope either in the original packaging or in a screen tray/container.

➤ Ensure that the endoscope is stored securely.

➤ Observe the respective valid national provisions when storing in a sterile condition.

12. Service and maintenance

Entellus Medical does not supply original parts to independent workshops or other endoscope manufacturers. Thus only Entellus Medical is in a position to carry out repairs using original parts. The original technical specifications and the operational safety of the endoscope can only be guaranteed by using original parts. The warranty for Entellus Medical products shall become void if repairs are carried out by a workshop not authorized by Entellus Medical. In this case Entellus Medical is also no longer responsible for the technical specifications or safety of the product.

➤ Have the endoscopes repaired by Entellus Medical only. For service, send the defective endoscope to Entellus Medical.

➤ Clean, disinfect and sterilize the endoscope thoroughly prior to returning it for repair.

➤ Ideally, send in the endoscope in its original packaging. If this is not possible, package the endoscope to secure it for transport.

Entellus Medical is not liable for damage resulting from improper shipping.



13. Accessories / spare parts

Designation	Article number
Polishing paste	8101001000
Adapter type Wolf	89530738
Adapter type Storz / Olympus	89542801

14. Disposal

- Observe country-specific regulations and laws for the disposal of medical products.

15. Symbols

<div style="border: 2px solid black; padding: 2px; display: inline-block;">REF</div> Reorder Number	 Quantity
<div style="border: 2px solid black; padding: 2px; display: inline-block;">Rx Only</div> Prescription Use Only	 Consult Instructions for Use
<div style="border: 2px solid black; padding: 2px; display: inline-block;">SN</div> Serial Number	 Device is Non Sterile

Manufactured For:
 Entellus Medical, Inc.
 3600 Holly Ln N
 Suite 40
 Plymouth, MN USA
 +1 866-620-7615
www.entellusmedical.com