

Maximize productivity

throughout your clinic

The Flash IIP Console

Intelligent Image and Information Processor

Designed to maximize productivity in the busiest environments, the Flash IIP is the intelligent image and information processor at the core of the OrthoCR product line.

Designed for patient identification, image review and image optimization, the Flash IIP integrates these multiple functions into one compact workstation.

The Flash IIP is so easy to use that a technologist can process an exam in as few as three clicks. Advanced image processing tools, such as the ability to type free text comments, image magnification and full screen display for detailed viewing, and automatic image stitching for scoliosis studies, are available when clinical demands are greater. No other system combines a convenient user interface with sophisticated software tools in a single workstation.

The minimal space requirements allow in-room installation and offer the most flexibility for placement. Multiple Flash IIP consoles can be networked to communicate with all of the OrthoCR readers in the department, improving flexibility and reducing potential workflow bottlenecks.



Easy to use

Minimal space requirements

Advanced processing tools

Professional Services

Dedicated Customer Service and Support

Stryker will not only provide you with the best technology, but will support our state-of-the-art products with a knowledgeable Service and Support team that will manage your transition to a digital domain.

Together with our partners, Stryker offers nationwide coverage with more service technicians and local representatives than all other orthopaedic PACS vendors combined. Because we believe in providing a complete solution, Stryker's Technical Assistance Center serves as a single point of contact for your service needs. One call to us is all that's necessary. Our representatives will coordinate with other vendors as required, ensuring your issues are promptly resolved.

Factory-trained professionals are dedicated to supporting the OrthoCR product line and have a wealth of resources to draw upon. Additionally, we sponsor advanced training programs for clinical and biomedical professionals, making adoption of digital x-ray as seamless as possible.

Industry leading 24x7 support

Factory-trained professionals

One number for nationwide service

Computed Radiography

from a name you can trust

The Stryker Difference. When you select a Stryker OrthoCR system, you can count on getting cutting-edge technology. All of our readers are the result of sophisticated mechanical engineering, superior optical technology and refined image processing software tools. Plus thousands of clinical users are included in the design process, making Stryker's OrthoCR systems as easy to use and efficient to operate as possible. When you go with the trusted market leader, you get a combination of expertise that no other digital imaging system can bring you.



Image Intelligence™

Exceptional Image Quality

An integral part of every OrthoCR system, Image Intelligence technologies ensure images are presented optimally every time. This advanced suite of tools improve diagnostic content and enhance image appearance for display, producing world-class image quality—a direct result of years of experience in refining images for interpretation.

Image Intelligence technologies mean that the first-up appearance of the image is correct and optimized for that procedure—saving technologists valuable time.

Image Intelligence Tools

- EDR (Exposure Data Recognizer) uses advanced neural networking logic to automatically detect the useful image information captured by the IP. Collimated areas and areas outside the imaged object are ignored to ideally present the diagnostic information.
- DRC (Dynamic Range Control) improves visibility of both dense and peripheral tissue by adjusting density and contrast characteristics.
- MFP (Multi-objective Frequency Processing) applies edge enhancement selectively to both small and large structures within an image.
- GPR (Grid Pattern Removal) prevents display of a moiré pattern caused by a stationary grid.
- FNC (Flexible Noise Control) extracts noise data and suppresses noise levels in images without losing diagnostic information from the image.



stryker®

Joint Replacements

Trauma, Extremities & Deformities

Craniomaxillofacial

Spine

Biologics

Surgical Products

Neuro & ENT

Interventional Pain

Navigation

Endoscopy

Communications

Imaging

Patient Handling Equipment

EMS Equipment

Rehabilitation Services

Stryker Imaging
1410 Lakeside Parkway #600
Flower Mound, TX 75028

t: 888 SYK IMAGE
www.stryker.com/imaging

The information presented in this brochure is intended to demonstrate a Stryker product. Always refer to the package insert, product label and/or user instructions before using any Stryker product. Products may not be available in all markets. Product availability is subject to the regulatory or medical practices that govern individual markets. Please contact your Stryker representative if you have questions about the availability of Stryker products in your area. Stryker Corporation or its divisions or other corporate affiliated entities own, use or have applied for the following trademarks or service marks: OrthoCR. All other trademarks are trademarks of their respective owners or holders.

Literature Number: MPP-016
BC/GG 5000 1/07

Copyright © 2007 Stryker
Printed in USA

stryker®

Imaging

OrthoCR™

Computed Radiography

High Quality Digital X-rays for
Orthopaedic Group Practices



OrthoCR XC-1

High quality digital x-ray for orthopaedic clinics

Processing Capacity (High Resolution 10 pixel/mm):

- 14" x 17" (35 x 43cm) 35 IPs/hour
- 14" x 14" (35 x 35cm) 40 IPs/hour
- 10" x 12" 45 IPs/hour
- 8" x 10" 56 IPs/hour
- 24 x 30cm (ST) 45 IPs/hour
- 18 x 24cm (ST) 60 IPs/hour

So small, yet so powerful. Stryker's OrthoCR XC-1 gives low volume clinics all the advantages of hospital quality digital x-ray, such as virtual elimination of repeat exams and lost films, lower storage and management costs and more options to enhance images.

The XC-1 is ideal for smaller practices with big image quality demands but without the imaging volume to justify the capacity and price of competitive systems. With a compact footprint of less than 2.5 square feet and a height of 32", the XC-1 easily fits into environments where space is at a premium.

Capable of processing up to 60 images per hour, the XC-1 is an ideal choice for practices with lower case loads that simply will not compromise on image quality.

It is also great for off-site locations that need to transmit images back to another practice. So no matter where image acquisition takes place, you get consistent, high-quality images every time.

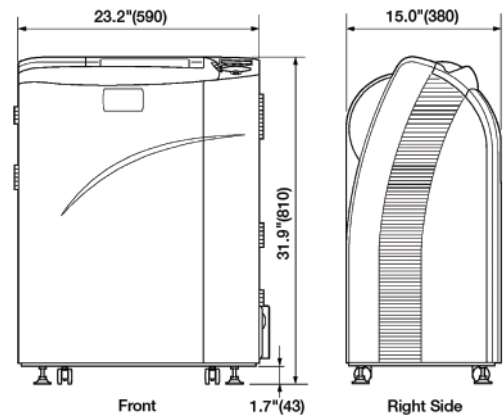

- Compact footprint
- Up to 60 IPs/hour
- Uncompromising image quality



OrthoCR XL-1

Perfect for higher-volume orthopaedic practices

Processing Capacity (High Resolution 10 pixel/mm):

- 14" x 17" (35 x 43cm) 62 IPs/hour
- 14" x 14" (35 x 35cm) 70 IPs/hour
- 10" x 12" 73 IPs/hour
- 8" x 10" 87 IPs/hour
- 24 x 30cm (ST) 75 IPs/hour
- 18 x 24cm (ST) 92 IPs/hour

Unparalleled productivity. Similar to the XC-1, the OrthoCR XL-1 provides the advantages of a digital x-ray solution in a small footprint. With exceptionally high throughput and image availability beginning in 10-12 seconds, the XL-1 is fast enough to handle busy periods in the most demanding environments.

Capable of processing up to 92 high quality images per hour—yet compact in design—the XL-1 is ideal for small exam rooms or offices where space is limited. With this kind of speed, the system also serves as a great redundancy solution.

The OrthoCR XC-1 and XL-1 are so efficient, clinic staff will wonder how they managed before. Both systems include a Flash IIP console, the first workstation to offer powerful productivity enhancing features that allow staff members to operate more efficiently, making the darkroom a thing of the past.

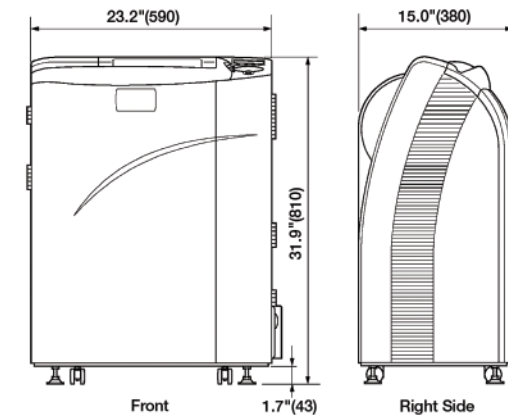

- Compact footprint
- Up to 92 IPs/hour
- Image availability in 10-12 seconds



OrthoCR XG2000

Scalable high-capacity dual cassette reader

Processing Capacity (High Resolution 10 pixel/mm):

- 14" x 17" (35 x 43cm) 103 IPs/hour
- 14" x 14" (35 x 35cm) 120 IPs/hour
- 10" x 12" 128 IPs/hour
- 8" x 10" 165 IPs/hour
- 24 x 30cm (ST) 128 IPs/hour
- 18 x 24cm (ST) 165 IPs/hour
- 24 x 30cm (HR) 90 IPs/hour
- 18 x 24cm (HR) 110 IPs/hour

Consistent image quality. The OrthoCR XG2000 produces images that have high diagnostic value and are easy to read. The system's wide latitude and automatic sensitivity adjustment function protects images from variations in x-ray exposure conditions, resulting in consistent image density for all radiographs.

The HQ reading mode provides high resolution (10 pixel/mm) image acquisitions and enables 100% size image output for the most demanding diagnostic situations without effecting system throughput.

Continuous workflow. Featuring two independent drives, the XG2000 can accept two cassettes at once, making it possible to efficiently process images and optimize user workflow.

Additionally, the XG2000 can be connected to multiple Flash IIP consoles and other OrthoCR reader units for maximum flexibility and redundancy.

Scalability. An industry exclusive, the XG2000 two slot cassette drive Image Reader is a scalable system that can be upgraded to a four drive reader as a facility's exam volume increases.

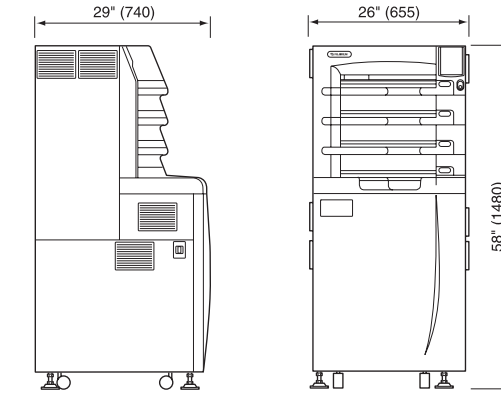

- Two independent cassette drives
- Scalable to four drives for increased volume
- High resolution with 100% size image output



OrthoCR XG5000

The fastest cassette-based system in its class

Processing Capacity (High Resolution 10 pixel/mm):

- 14" x 17" (35 x 43cm) 103 IPs/hour
- 14" x 14" (35 x 35cm) 120 IPs/hour
- 10" x 12" 128 IPs/hour
- 8" x 10" 165 IPs/hour
- 24 x 30cm (ST) 128 IPs/hour
- 18 x 24cm (ST) 165 IPs/hour
- 24 x 30cm (HR) 90 IPs/hour
- 18 x 24cm (HR) 110 IPs/hour

Fast throughput. With a throughput of up to 165 Imaging Plates (IPs)/hour, no other cassette-based system in its class beats the OrthoCR XG5000. Its four cassette drives and product design allow IPs to be read and erased simultaneously for image previews in as little as 15 seconds and cycle times as short as 30 seconds. And the XG5000 is not just fast, it produces consistent, high quality images to optimize your clinical workflow. Stryker recognizes that these features are basic requirements for efficient radiological environments and we strive to make sure our equipment exceeds them to the extent that our products are the best in the industry.

Built-in redundancy. The XG5000 is the only multi-plate system to offer the built-in redundancy of independent cassette drives. Four independent drives are used to process images so there is no single point of failure.

Maximum efficiency. Another feature that maximizes uptime is Fuji's minimal contact cassette design, which only calls for a small portion of the cassette to be inserted into the reader. This reduces the likelihood of jams and virtually eliminates foreign objects from entering the reader. It also reduces the incidence of dirt and debris commonly found on cassettes from going into the reader, which can cause artifacts and additional wear and tear on system optics.

The XG5000 can read and erase a storage-phosphor IP more efficiently than any digital x-ray reader in its class. And our flexible IP, the most durable one in the industry, is key to maintaining the reader's compact size, superior imaging and quick cycle time.

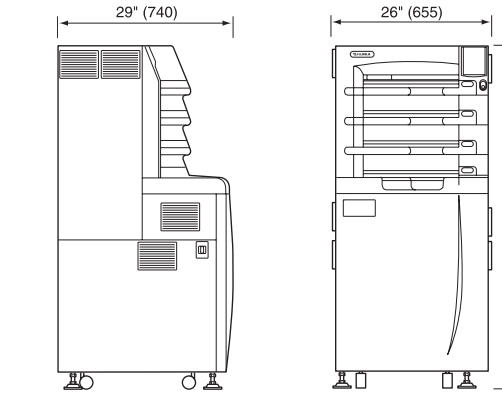

- Four independent cassette drives
- Up to 165 IPs/hour

