

Crossfire™ Console

REF 0475000000

stryker®

User Guide

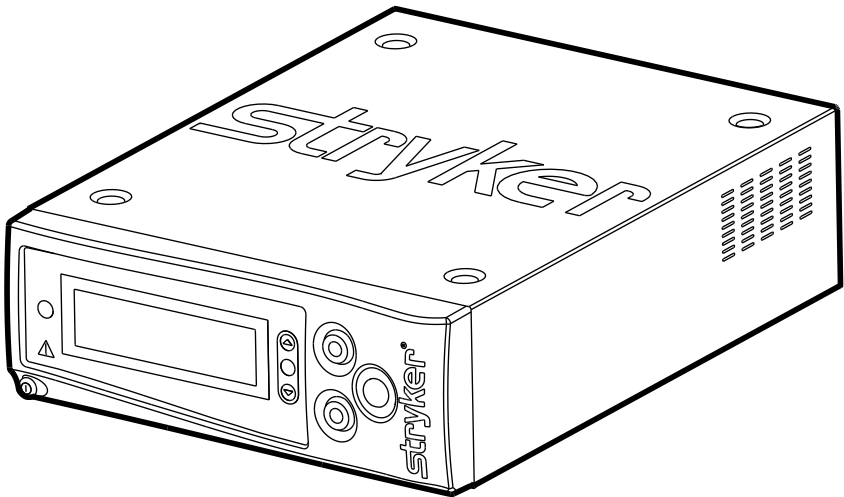

R_x ONLY

Contents

Warnings and Cautions	3
Symbol Glossary	7
Product Description and Intended Use	9
Indications/Contraindications	10
Package Contents	10
Available Accessories	10
The Crossfire™ Console	11
Setup and Interconnection	13
Electromagnetic Compatibility	13
Connections.....	18
Powering the Console On and Off	20
Operation	21
The Crossfire™ Interface	22
Adjusting User and System Settings	23
Reading the LCD Screen	25
Selecting Between RF and Shaver Modes	28
Selecting Force Modulation in RF Mode	28
Adjusting Power and Speed Settings	28
Using the Handpiece	29
Using the Footswitch	30
Audible Feedback	34
Troubleshooting	35
Cleaning and Maintenance	37
Cleaning	37
Disposal	38
Technical Specifications	39
Generator Output.....	39

Warnings and Cautions

Please read this manual and follow its instructions carefully. The words warning, caution, and note carry special meanings and should be carefully reviewed:

Warning	Warnings indicate risks to the safety of the patient or user. Failure to follow warnings may result in injury to the patient or user.
Caution	Cautions indicate risks to the equipment. Failure to follow cautions may result in product damage.
Note	Notes provide special information to clarify instructions or present additional useful information.

To avoid potential serious injury to the user and the patient and/or damage to this device, the user must obey the following warnings. The warranty is void if any of these warnings is disregarded.

1. Federal law (USA) restricts this device to use by, or on order of, a physician.
2. Attempt no internal repairs or adjustments not specifically detailed in this operating manual. Refer any readjustments, modifications, and/or repairs to Stryker Endoscopy or its authorized representatives.
3. Pay close attention to the care and cleaning instructions in this manual. Failure to follow these instructions may result in product damage.
4. Install this device in an operating room that complies with all applicable IEC, CEC, and NEC requirements for safety of electrical devices.
5. DO NOT use the Crossfire™ system on patients with cardiac pacemakers or other electronic device implants. Doing so could lead to electromagnetic interference and possible death.

Fire/Explosion Warnings

1. DO NOT use this device in the presence of flammable anaesthetics, other flammable gases or objects, near flammable fluids such as skin prepping agents and tinctures, or oxidizing agents. Observe appropriate fire precautions at all times.
2. DO NOT use this device in oxygen-enriched atmospheres, nitrous oxide (N₂O) atmospheres, or in the presence of other oxidizing agents, to prevent risk of explosion. Ensure that oxygen connections are not leaking.

3. Electrosurgical components, such as the probe, may remain hot following activation. Keep all electrosurgical equipment away from flammable materials to avoid combustion.
4. To prevent the risk of fire, DO NOT replace console fuses. If it is suspected that fuses are damaged, return console to Stryker for repair.

Prior to Surgery

1. The operator of the Crossfire™ system should be a qualified physician, having complete knowledge of the use of this equipment and awareness of the risks associated with arthroscopic and electrosurgical procedures.
2. The operator of the Crossfire™ system should be experienced in arthroscopic and electrosurgical practices and techniques.
3. The operator of the Crossfire™ system should read this manual thoroughly and be familiar with its contents prior to operating the equipment.
4. The operator of the Crossfire™ system should be sure that the system functions as outlined in this manual prior to a surgical procedure. The Crossfire™ system was fully tested at the factory before shipment.
5. Crossfire™ system components are designed to be used together as a system. Use only the appropriate footswitch, handpiece, and disposable attachments described in this manual.
6. Carefully unpack the unit and ensure that all components are accounted for and remain undamaged from shipment. Inspect the handpiece cable for any damage to insulation. If damage to any component is detected, refer to the “Service and Claims” section of this manual.
7. Ensure the proper connection of the primary power cord of the Crossfire™ System to a grounded receptacle. To prevent risk of electric shock DO NOT use extension cords or adapter plugs.
8. DO NOT wrap the handpiece cable around metal objects, or the induction of hazardous currents may result.
9. Position the cables to avoid contact with the patient, electrodes, cables, and any other electrical leads which provide paths for high frequency current.
10. Position the console so the fan directs the flow of air away from the patient.
11. When the Crossfire™ system and physiological monitoring equipment are used simultaneously on a patient, position any monitoring electrodes as far as possible from the surgical electrodes. Monitoring equipment using high frequency, current-limiting devices is recommended. Needle monitoring electrodes are NOT recommended.

12. Smoke generated during electrosurgical procedures may be harmful to surgical personnel. Take appropriate precautions by wearing surgical masks or other means of protection.

During Surgery

1. DO NOT use the Crossfire™ system with non-conductive irrigants (e.g. sterile water, air, gas, glycine, etc.). Use only conductive irrigants such as saline or Ringer's lactate in order for the system to function properly.
2. DO NOT allow the patient to come into contact with grounded metal objects or objects that have an appreciable capacitance to the earth, such as a surgical table frame or instrument table, to prevent risk of shock. The use of antistatic sheeting is recommended for this purpose.
3. DO NOT activate the Crossfire™ system for prolonged lengths of time when the attachment is not in contact with tissue. Doing so may lead to unintentional damage to surrounding tissue.
4. When the Crossfire™ system is activated, the conducted and radiated electrical fields may interfere with other electrical medical equipment. Provide as much possible distance between the console and other electronic medical equipment.
5. Select the lowest output power required to prevent patient injury.
6. Maintain the active electrode in the field of view at all times to avoid tissue damage.
7. Remove the handpiece and disposable attachments from the surgical site and place them away from metallic objects when not in use. Attachments should be separated from other electrosurgical equipment to avoid inadvertent electrical coupling between devices. Inadvertent activation may cause user/patient injury and/or product damage.
8. Keep the ends of the handpiece cable connectors, footswitch cable connectors, and console receptacles away from all fluids.
9. DO NOT activate the Crossfire™ system until the probe is properly positioned in the patient.
10. Ensure that the probe tip, including the return electrode, is completely surrounded by irrigant solution during use.
11. Keep the activation indication lights and speaker in field of view and hearing at all times during activation. The light and sound are important safety features.
12. DO NOT touch the attachment to metal objects, such as an endoscope or metal cannula, while activating the handpiece. Damage to the attachments or other devices may result.
13. DO NOT obstruct the fan (located near the rear of the console).

14. Failure of the system may result in an unintended increase in output power.
15. During use, operators should wear standard surgical gloves to help reduce the risk of electric shock.

After Surgery

1. DO NOT attempt to reuse or resterilize any product labeled “Single-Use,” as this may lead to equipment malfunction, patient/user injury, and/or cross contamination.
2. DO NOT use flammable agents for cleaning and disinfection of the Crossfire™ console, handpiece, or footswitch.
3. DO NOT remove the cover of the console as this could cause electric shock and product damage.
4. Attempt no internal repairs or adjustments, unless specified otherwise in this manual. Units requiring repair should be returned to Stryker.
5. Disconnect the Crossfire™ system from the electrical output when inspecting fuses.

Symbol Glossary

This device and its labeling contain symbols that provide important information for the safe and proper use of the device. These symbols are defined below.

Warning Symbols



Warning/Caution:
See instructions for
use



Hazardous voltage present

Front Console Symbols



Power



Up



Menu



Probe



Select



Down



Footswitch



Handpiece

Rear Console Symbols



Equipotentiality



Stryker firewire



Type BF rated



USB



Emits RF radiation



Protective ground earth



Fuse rating



UL classified



Compliant to CSA C22.2 No. 601.1-M90, and UL 601-1



Fulfills requirements of the European Medical Device Directive 93/42/EEC

LCD Symbols



Electrosurgical unit



Contrast



Brightness



Sound

Packaging/Labeling Symbols



Legal manufacturer



Authorized representative in Europe



Date of manufacture

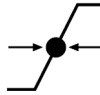

Atmospheric pressure range



Ambient temperature range



Relative humidity range



Lot number



Product number



Serial number



Fragile



This product contains electrical waste or electronic equipment. It must not be disposed of as unsorted municipal waste and must be collected separately.

Product Description and Intended Use

The Crossfire™ Integrated Arthroscopy System is a combination powered shaver system/electrosurgical generator, intended for use in arthroscopic and orthopedic procedures.

Illustrated below, the Crossfire™ system consists of the following components:

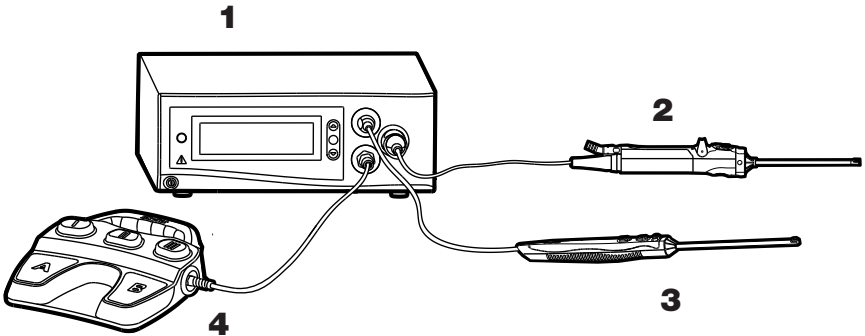

- 1. Crossfire™ Console** (featured in this manual)
 - Acts as a connection hub for the various components of the Crossfire™ system
 - Powers a motorized shaver handpiece for the mechanical cutting and debridement of bone and soft tissue
 - Generates bipolar radio frequency (RF) energy for the electrosurgical cutting and coagulation of tissue
 - Provides a central user interface for operating the Crossfire™ system
- 2. Disposable RF probe** Enables RF cutting and coagulation
- 3. Powered shaver handpiece** (and disposable attachments) Enables arthroscopic cutting and debridement
- 4. Crossfire™ Footswitch** Provides remote, foot control of the powered shaver handpiece and RF probe

Indications/Contraindications

The Crossfire™ system is **indicated** for use in orthopedic and arthroscopic procedures for the knee, shoulder, ankle, elbow, wrist, and hip. The Crossfire™ System provides abrasion, resection, debridement, and removal of bone and soft tissue through its shaver blade, and the ablation and coagulation of soft tissue, as well as hemostasis of blood vessels, through its electro-surgical probe.

Examples of uses of the product include resection, ablation, and coagulation of torn knee cartilage, subacromial decompression, and resection of synovial tissue in other joints.

The electro-surgical probe is **contraindicated** for use in procedures where a nonconductive irrigant is used or with patients having cardiac pacemakers or other electronic implants.

Package Contents

Carefully unpack the Crossfire™ console and inspect each of the following components. Report any damaged components to Stryker.

- (1) Crossfire™ console
- (1) Hospital-grade power cord (0105-003-001)
- (1) User guide

Available Accessories

The Crossfire™ system is compatible with the following accessories:

0475-000-100	Crossfire™ Footswitch
0279-xxx-xxx	SERFAS™ Energy family of electro-surgical probes
0375-708-500	Formula® 180 Handpiece
0375-704-500	Formula® Handpiece (with buttons)
0375-701-500	Formula® Handpiece (without buttons)
0275-601-500	Small-Joint Shaver Handpiece
0277-200-100	iSWITCH™ Universal Wireless Footswitch Receiver
0277-100-100	iSWITCH™ Universal Wireless Footswitch
6000-001-020	Stryker firewire cable

Note: Instructions for use can be found in the following manuals:

- Crossfire™ Console:** 1000-401-036 (English) or P11344 (international)
- Crossfire™ Footswitch:** 1000-401-032 (English) or P11345 (international)







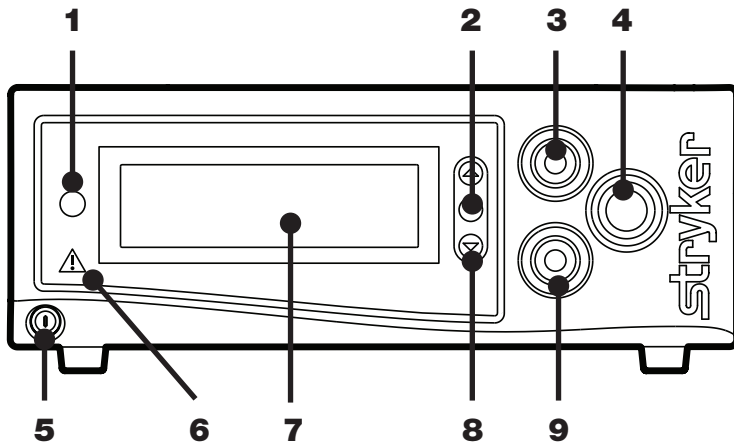

The Crossfire™ Console

The Crossfire™ console is the connection hub for the components of the Crossfire™ system. It generates RF energy, powers motorized shavers, and provides user controls and system feedback.

Front Panel

The front console panel features ports for connecting handpieces, controls for adjusting handpiece settings, and an LCD screen to provide system feedback.





- | | | |
|--------------------------------|---|---|
| 1. Menu | Selects menu items |  |
| 2. Select | Selects which device displays on the LCD screen. |  |
| 3. RF connector | SERFAS Energy probe |  |
| 4. Handpiece connector | Powered shaver handpiece |  |
| 5. Power | Powers the console on and off |  |
| 6. Error indicator | Shines red to indicate errors (error details appear in the LCD) |  |
| 7. LCD screen | Provides system feedback | |
| 8. Adjust | Adjusts options for connected devices |  |
| 9. Footswitch connector | Crossfire™ Footswitch |  |

Rear Panel

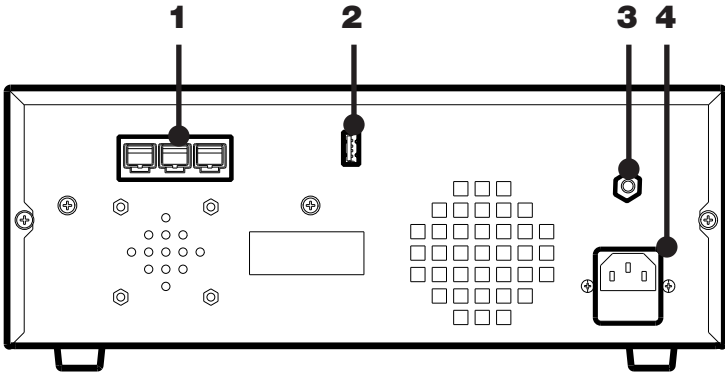
The rear panel provides ports for connecting the console to other Stryker equipment.



- | | | |
|------------------------------|---|---|
| 1. Firewire Connectors | Enables connection to other Stryker Firewire devices, such as the iSWITCH Universal Wireless Footswitch |  |
| 2. USB Drive | Enables uploading of preset user settings |  |
| 3. Equipotential Ground Plug | — |  |
| 4. AC Power Inlet | — | |

Setup and Interconnection

Stryker Endoscopy considers instructional training an integral part of the Crossfire™ system. Your Stryker Endoscopy sales representative will perform at least one inservice at your convenience to help you set up your equipment and instruct you and your staff on its operation and maintenance. Please contact your local Stryker Endoscopy representative to schedule an in-service after your equipment has arrived.

Electromagnetic Compatibility

Like other electrical medical equipment, the Crossfire™ System requires special precautions to ensure electromagnetic compatibility with other electrical medical devices. To ensure electromagnetic compatibility (EMC), the Crossfire™ System must be installed and operated according to the EMC information provided in this manual.

The Crossfire™ System has been designed and tested to comply with IEC 60601-1-2:2001 requirements for EMC with other devices.

Warning



This equipment is intended for use by health care professionals only. This equipment may cause radio interference or may disrupt the operation of nearby equipment. It may be necessary to take mitigation measures, such as reorienting or relocating the equipment or shielding the location.

Portable and mobile RF communications equipment can affect the normal function of the Crossfire™ System even if such equipment meets the applicable emissions requirements.

The Crossfire™ System was not tested for immunity to electromagnetic disturbances.

Do not use cables or accessories other than those provided with the Crossfire™ System, as this may result in increased electromagnetic emissions or decreased immunity to such emissions.

If the Crossfire™ System is used adjacent to or stacked with other equipment, observe and verify normal operation of the Crossfire™ System in the configuration in which it will be used prior to using it in a surgical procedure as interference may occur. Consult the tables below for guidance in placing the Crossfire™ System.

When the Crossfire™ System is interconnected with other medical electrical equipment, leakage currents may be additive. To minimize total patient leakage current, any Type BF applied part should be used together with other Type BF applied parts. Ensure all systems are installed according to the requirements of IEC 60601-1-1.

The separable AC power cord is provided as a means of emergency shutdown and disconnection from the power source. Do not position the console in a way that is difficult to disconnect the AC power cord.

Guidance and Manufacturer's Declaration: Electromagnetic Emissions		
The Crossfire™ System is intended for use in the electromagnetic environment specified below. The customer or the user of Crossfire™ System should ensure that it is used in such an environment.		
Emissions Test	Compliance	Electromagnetic Environment - Guidance
RF emissions CISPR11	Group 1	The Crossfire™ System must emit electromagnetic energy in order to perform its intended function. Nearby electronic equipment may be affected.
RF emissions CISPR11	Class A	Crossfire™ System is suitable for use in all establishments other than domestic and those directly connected to the public low-voltage power supply network that supplies buildings used for domestic purposes.
Harmonic emissions IEC 61000-3-2	Class A	
Voltage Fluctuations/flicker emissions IEC 61000-3-3	Complies	

Guidance and Manufacturer's Declaration: Electromagnetic Immunity

The Crossfire™ System is intended for use in the electromagnetic environment specified below. The customer or the user of Crossfire™ System should ensure that it is used in such an environment

Immunity Test	IEC 60601 Test Level	Compliance Level	Electromagnetic Environment: Guidance
Electrostatic Discharge (ESD) IEC 61000-4-2	±6kV contact ±8kV air	±2,4,6kV contact ±2,4,8kV air	Floors should be wood, concrete, or ceramic tile. If floors are covered with synthetic material, the relative humidity should be at least 30%.
Electrical fast transient/burst IEC 61000-4-4	±2kV for power supply lines ±1kV for input/output lines	±2kV for power supply lines ±1kV for input/output lines	Mains power quality should be that of a typical commercial or hospital environment.
Surge IEC 61000-4-5	±1kV differential mode ±2kV common mode	±0.5, 1kV differential mode ±1, 2kV common mode	Mains power quality should be that of a typical commercial or hospital environment.
Voltage dips, short interruptions and voltage variations on power supply input lines IEC 61000-4-11	<5% Ut (>95% dip in Ut) for 0.5 cycle 40% Ut (60% dip in Ut) for 5 cycles 70% Ut (30% dip in Ut) for 25 cycles <5% Ut (>95% dip in Ut) for 5 sec.	<5% Ut (>95% dip in Ut) for 0.5 cycle 40% Ut (60% dip in Ut) for 5 cycles 70% Ut (30% dip in Ut) for 25 cycles <5% Ut (>95% dip in Ut) for 5 sec.	Mains power quality should be that of a typical commercial or hospital environment. If the user of Crossfire™ System requires continued operation during power mains interruptions, it is recommended that Crossfire™ System be powered from an uninterruptible power supply or a battery.
Power frequency (50/60Hz) magnetic field IEC 61000-4-8	3 A/m	N/A	Power-frequency magnetic fields should be at levels characteristic of a typical location in a typical commercial or hospital environment.

NOTE: Ut is the a.c. mains voltage prior to application of the test level.

Guidance and Manufacturer's Declaration: Electromagnetic Immunity

Crossfire™ System is intended for use in the electromagnetic environment specified below. The customer or the user of Crossfire™ System should ensure that it is used in such an environment.

Immunity Test	IEC 60601 Test Level	Compliance Level	Electromagnetic Environment: Guidance
Conducted RF IEC 61000-4-6	3 Vrms 150 kHz to 80 MHz	3 V	<p>Portable and mobile RF communications equipment should be used no closer to any part of the Crossfire™ system, including its cables, than the recommended separation distance calculated from the equation applicable to the frequency of the transmitter.</p> <p>Recommended Separation Distance $d = 1.17 \sqrt{P}$ 80 MHz to 800 MHz</p> <p>where P is the maximum output power rating of the transmitter in watts (W) according to the transmitter manufacturer and d is the recommended separation distance in meters (m).</p> <p>Field strengths from fixed RF transmitters, as determined by an electromagnetic site survey (a), should be less than the compliance level in each frequency range(b). Interference may occur in the vicinity of equipment marked with the following symbol:</p> 
Radiated RF IEC 61000-4-3	3 V/m 80MHz to 2.5 GHz	3 V/m	
NOTE 1: At 80 MHz and 800 MHz, the higher frequency range applies.			
NOTE 2: These guidelines may not apply in all situations. Electromagnetic propagation is affected by absorption and reflection from structures, objects, and people.			
<p>(a) Field strengths from fixed transmitters, such as base stations for radio (cellular/cordless) telephones and land mobile radios, amateur radio, AM and FM radio broadcast, and TV broadcast, cannot be predicted theoretically with accuracy. To assess the electromagnetic environment due to fixed RF transmitters, an electromagnetic site survey should be considered. If the measured field strength in the location in which the Crossfire™ System is used exceeds the applicable RF compliance level above, the Crossfire™ System should be observed to verify normal operation. If abnormal performance is observed, additional measures may be necessary, such as reorienting or relocating the Crossfire™ System.</p> <p>(b) Over the frequency range 150 kHz to 80 MHz, field strengths should be less than 3 V/m.</p>			

Recommended Separation Distances Between Portable and Mobile RF Communications Equipment and the Crossfire™ System

The Crossfire™ System is intended for use in an electromagnetic environment in which radiated RF disturbances are controlled. The user of the Crossfire™ System can help prevent electromagnetic interference by maintaining a minimum distance between portable and mobile RF communications equipment (transmitters) and the Crossfire™ System as recommended below, according to the maximum output power of the communications equipment.

Rated maximum output power (W) of transmitter	Separation distance (m) according to frequency of transmitter		
	150 kHz to 80 MHz	80 MHz to 800 MHz	800 MHz to 2.5 GHz
0.01	0.12	0.12	0.23
0.1	0.37	0.37	0.74
1	1.17	1.17	3.70
10	3.70	2.33	7.37
100	11.70	11.70	23.30
For transmitters rated at a maximum output power not listed above, the recommended separation distance (d) in meters (m) can be estimated using the equation applicable to the frequency of the transmitter, where P is the maximum output power rating of the transmitter in watts (W) according to the transmitter manufacturer.			
NOTE 1: At 80 MHz and 800 MHz, the separation distance for the higher frequency range applies.			
NOTE 2: These guidelines may not apply in all situations. Electromagnetic propagation is affected by absorption and reflection from structures, objects, and people.			

Connections

Warning



Be sure that no liquid is present between connections to the console and the handpiece. Connection of wet accessories may lead to electric shock or electrical short.

To avoid the risk of electric shock, this equipment must only be connected to a supply mains with protective earth.

Use only hospital-grade power cables. Using other cables may result in increased RF emissions or decreased immunity from such emissions.

Only the handpieces and disposable attachments are suitable for use in the patient environment. The console and footswitch are not sterile devices and should not enter the sterile field.

The Crossfire™ System is compatible only with the Stryker handpieces and footswitches listed in this manual. Do not connect any equipment not specified in this manual, as unexpected results or serious injury will occur.

1. Place the console on a sturdy platform, such as a Stryker cart.
 - Select a location according to the recommendations in the preceding EMC tables.
 - Leave four inches of space around all sides for convection cooling.

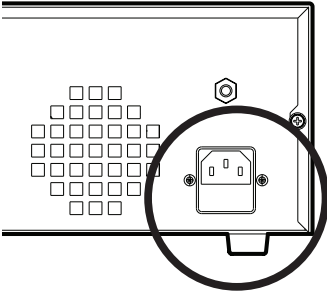

2. Connect the AC power.

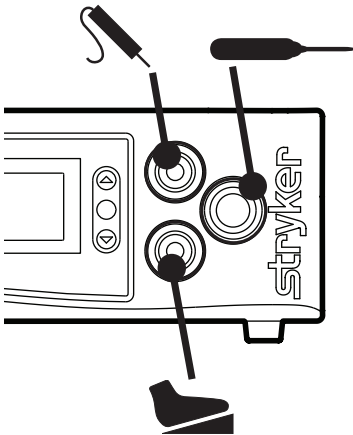

3. Connect the handpieces and footswitch.

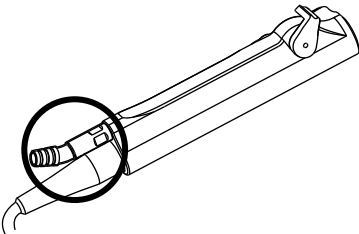

4. Connect suction tubing (for all suction-capable devices).

Powering the Console On and Off

Press the power button to power the console on and off. The button will shine green when the console is on.

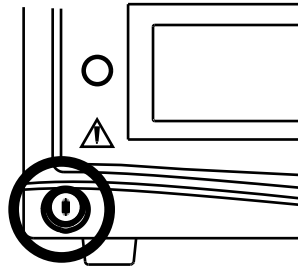

Warning



Should emergency shutdown become necessary, power off the console as described above. As an added safety measure, the console can be separated from the AC power mains by detaching the AC power cord from either end.

Operation

The Crossfire™ interface displays system status, enables you to choose between RF and shaver modes, and enables you to adjust power and speed settings.

Activating the actual handpieces is performed through controls on the handpiece and on the Crossfire™ Footswitch.

Warning



The Crossfire™ system is intended for use only by licensed medical professionals, properly trained in the use of electrosurgical equipment and techniques. The Crossfire™ system generates potentially hazardous levels of energy that can result in injury or even death if improperly used.

Before using the Crossfire™ system in an actual procedure, verify that each component is installed and functioning properly. Improper connection may cause arcing or malfunction of the handpiece or console, which can result in injury, unintended surgical effect, or product damage.

During use, operators should wear standard surgical gloves to help reduce the risk of electric shock.

The Crossfire™ Interface

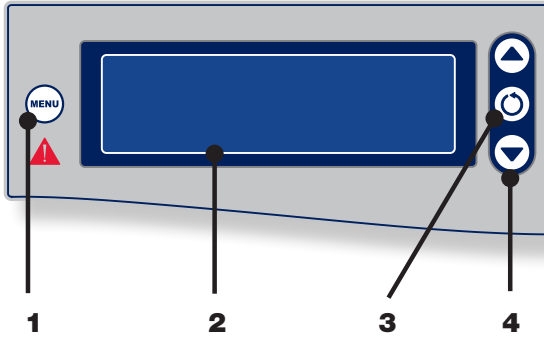





Control	Description	See
1. Menu	The Menu button sets user and system settings.	“Adjusting User and System Settings”
2. LCD screen	The LCD screen displays system status, error codes, mode of operation, cutting speed, and power levels.	“Reading the LCD Screen”
3. Select	The Select button toggles between RF and Shaver controls. The selected device can then be controlled using the Crossfire™ interface.	“Selecting Between RF and Shaver Modes”
4. Adjust	The Adjust buttons increase/decrease speed and power settings for the selected device.	“Adjusting Power and Speed Settings”

Adjusting User and System Settings

User Preference Settings

User preferences, such as power and cutting speeds and button assignments for the handpiece and footswitch, can be adjusted through the Crossfire™ interface.

Select from the default settings provided with the console, or contact your Stryker representative to customize your own.

1. Press .
2. Press   to select a default setting.
3. Press  to confirm selection and exit.
Or, press  to cancel selection.

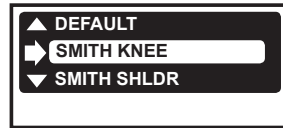









Note: User preference settings will not take effect unless a disposable attachment is connected to the shaver.

Note: When using small-joint handpieces, system defaults will take effect (see “Default Shaver Controls”). No user preferences can be applied.

System Settings

System settings, such as screen brightness, contrast, and system sound can be adjusted through the Crossfire™ interface.

1. Press and hold .
2. Press  to choose ,  (brightness), or  (sound).
3. Press   to adjust.
4. Press and hold  to exit.



(Note: A short press will display the current version of the console software.)





Reading the LCD Screen

The LCD screen displays the devices that are connected to the console and their current status.

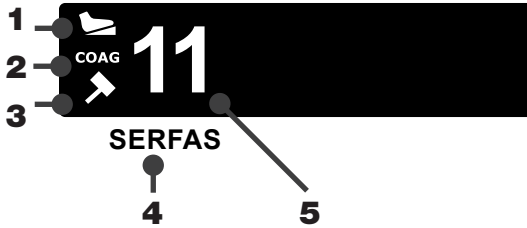
RF Mode

In RF mode, the LCD will show:



1. Footswitch status		Crossfire footswitch connected
		iSwitch footswitch connected
		not connected
2. Mode		cut mode
		coagulation mode
3. Force modulation		force modulation activated
		force modulation not activated
4. Probe name	(name)	
5. Power	(#)	power setting

Shaver Mode

In shaver mode, the LCD will show:

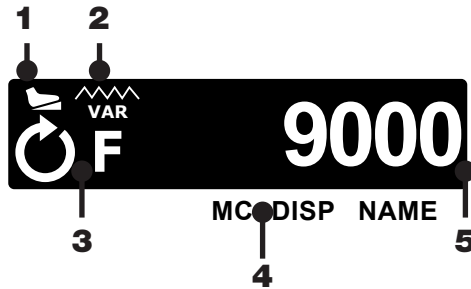

1. Footswitch status



Crossfire footswitch connected



iSWITCH footswitch connected

not connected

2. Button response



one touch

(pressing the shaver button once will activate the shaver to a default speed; pressing again will stop it)



fixed

(pressing the shaver button at any pressure will result in a constant speed)



variable (for small-joint handpieces)

(shaver speed will vary, depending on the pressure applied to the shaver button)

3. Direction



forward



reverse



oscillate

4. Cutter name

(name)

5. Speed

(#) rotations per minute

Dual Mode

In dual mode, the LCD will show the status of both devices. The shaver status will always appear to the right, except during adjustments to RF settings.

To select between RF and shaver modes, press .



Dual mode, normal screen.



Dual mode, adjustments being made to RF power settings

The screen will revert to normal after 5 seconds of inactivity.

Selecting Between RF and Shaver Modes

To select the appropriate mode, do one of the following:

- Press  on the Crossfire interface. The interface will toggle between modes.
- Press the mode button on the footswitch.
- Press any button on the desired handpiece.

Selecting Force Modulation in RF Mode

The Crossfire Console features an additional RF mode known as Force Modulation. Force Modulation is an alternative ablation mode that duty cycles RF output at a low frequency to achieve a lower average power output than in normal CUT mode.

Currently, Force Modulation is an option only with the following SERFAS Energy probes: 90-S, 90-S Max, and Super 90-S.

- **To activate Force Modulation**, hold down the grey power button on the SERFAS probe for three seconds. A hammer icon  will appear on the LCD screen of the console, indicating Force Modulation activated.
- **To deactivate Force Modulation**, hold down the grey power button on the SERFAS probe for three seconds. The hammer icon will disappear from the LCD screen.

Adjusting Power and Speed Settings

Use the   buttons on the console to manually adjust the power or speed setting for the active handpiece.

Note: Forward and reverse settings are adjusted independent of each other. Adjusting settings in one mode will not affect the other.

Note: In RF mode, power can also be adjusted with the buttons on the handpiece or footswitch.

Note: To switch between CUT and COAG in RF mode, use the buttons on the handpiece or footswitch.

Note: In shaver mode, the console uses radio frequency identification (RFID) to automatically detect which type of disposable attachment is connected to the handpiece. Upon recognition, the console adjusts to an optimal preset cutting speed, direction, and power.

Using the Handpiece

Warning



During use, the RF and shaver handpieces generate electronic noise that may interfere with EKG readings. Before responding to any erratic EKG readings, first power down the system to ensure the readings are not the result of system noise.

RF handpieces are intended for single use only and should not be reprocessed or reused.

Shaver handpieces are provided nonsterile and must be cleaned and sterilized prior to each use, according to the reprocessing instructions provided in the handpiece manual.

Each handpiece has its own set of controls.

RF Hand Controls

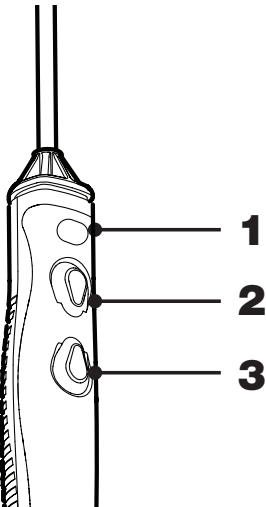

1. Adjust CUT power level (single press)

or

Activate/deactivate Force Modulation
(press and hold for three seconds)

2. Activate CUT
3. Activate COAG

Shaver Hand Controls

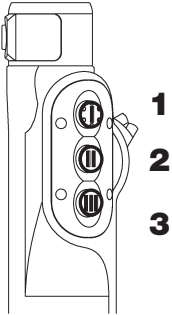

	Default 1	Default 2 / None	Default 3
1.	Oscillate (one-touch)	Activate	Oscillate (one-touch)
2.	Forward (one-touch)	Select Mode: Oscillate or Forward /Reverse	Jog
3.	Reverse (one-touch)	Forward/ Reverse	Forward (one-touch)

Using the Footswitch

The RF and shaver handpieces can also be controlled by the Crossfire™ Footswitch. The default footswitch controls are shown below. To customize button assignments, contact your Stryker representative.

Note: For more detailed information on the Crossfire™ Footswitch, consult the *Crossfire™ Footswitch User Guide* (English: 1000-401-032; International: P11345).

Note: To keep the footswitch clean during use, Stryker recommends using disposable bags (P/N 0277-500-100). Contact your local Stryker representative for ordering information.

Default RF Controls

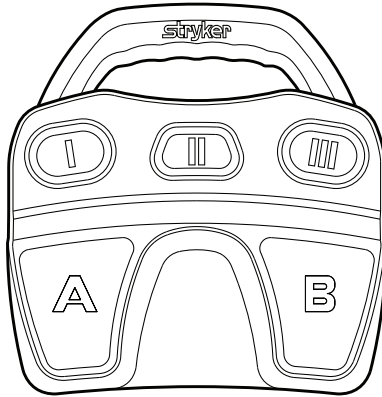

Button	Function (controls are the same for defaults 1, 2, and 3)
I	Decrease Cut Level
II	Select Handpiece: RF or Shaver
III	Increase Cut Level
A	Cut
B	Coag

Default Shaver Controls

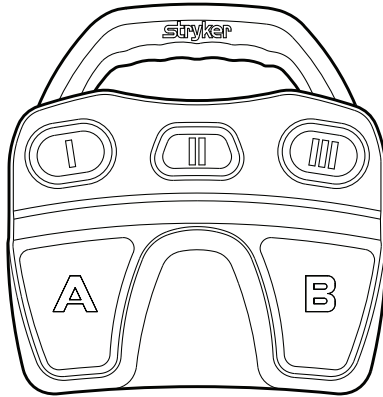

Button	Function		
	Default 1	Default 2 / None	Default 3
I	Jog	Select Mode: Oscillate or Forward/Reverse	Select Mode: Oscillate or Forward/Reverse
II	Select Handpiece: RF or Shaver	Select Handpiece: RF or Shaver	Select Handpiece: RF or Shaver
III	Select Direction: Forward or Reverse	Select Speed: High or Low	Select Speed: High or Low
A	Oscillate (fixed)	Oscillate/Reverse (variable)	Oscillate/Reverse (fixed)
B	Forward/Reverse (variable)	Oscillate/Forward (variable)	Oscillate/Forward (fixed)

Note: When using small-joint handpieces, only Default 2 settings are available. No other defaults or user preferences can be applied.

Using the iSWITCH™ Wireless Footswitch

The Crossfire™ system can be used with the iSWITCH Wireless Footswitch System.

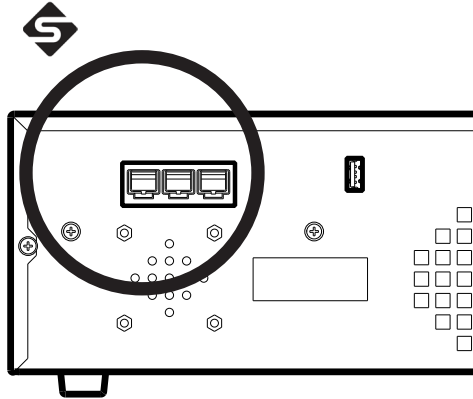

1. Connect the Crossfire™ console to the iSWITCH™ console using one of the Firewire connection ports on each console.
2. Consult the iSWITCH™ Operating and Maintenance Manual (P/N 1000-400-700) for further operation instructions.

Audible Feedback

The Crossfire™ Console will provide audible feedback for the following events:

Event	Signal
During system startup	
System self-test	Two-second beep
Handpiece connected	Single beep
Disposable attachment connected	Single beep
Footswitch detected	Single beep
RF probe detected	Single beep
During use	
RF COAG mode active	Continuous tone (low)
RF CUT mode active	Continuous tone (high)
System error	Three beeps
Force modulation on / off	Single beep
Shaver reverse mode activated	Five short beeps
Toggle (from footswitch) between RF and Shaver	The console will say, “Shaver” or “SERFAS”

Troubleshooting

	Problem	Possible Solution
Console	A hardware fault is detected	<ul style="list-style-type: none"> • Turn the power off and on again. • If the problem persists, contact a Stryker representative or return the console for repair.
	The AC voltage is incorrect	<ul style="list-style-type: none"> • Turn the power off and on again. • If the problem persists, contact a Stryker representative or return the console for repair.
	A software default is detected	<ul style="list-style-type: none"> • Turn the power off and on again. • If the problem persists, contact a Stryker representative or return the console for repair.
	The system does not power on	<ul style="list-style-type: none"> • Check the power cord to ensure it is properly connected. • Check to ensure the cord is connected to a grounded outlet.
	The electrical interference is sporadic	<ul style="list-style-type: none"> • Power down all electrical equipment not in use. • Increase distance of other electrical equipment. • Connect the unit and other equipment into different outlets.
	The generator temperature is too high	Ensure that there is proper airflow around the unit.
Hand-piece	A power-on self test error has occurred	<ul style="list-style-type: none"> • Turn the power off and on again. • If the problem persists, contact a Stryker representative or return the console for repair.
	The temperature is higher than normal	Allow the unit to cool before restarting.
	The unit has reached its recommended service interval	Contact your Stryker representative.

Disposable Attachments	RF probe is not ready	Check the connection to the console.
	RF probe is expired	Replace probe.
	RF probe identification is invalid	Replace probe.
	RF probe communication error	<ul style="list-style-type: none"> • Check the connection to the console. • If necessary, replace probe.
	Exceeded time usage	Replace probe
	RF power is too high	<ul style="list-style-type: none"> • Check the probe for damage. • If necessary, replace probe.
	RF voltage is too high	<ul style="list-style-type: none"> • Check the probe for damage. • If necessary, replace probe.
	RF current is too high	<ul style="list-style-type: none"> • Check the probe for damage. • If necessary, replace probe.
	RF delivery has exceeded continuous limit	Clear error and continue
	Low impedance detected	<ul style="list-style-type: none"> • Check the probe for damage. • If necessary, replace probe.
Footswitch	A wireless footswitch is detected	Disconnect the wired footswitch.
	The footswitch icon does not appear	<ul style="list-style-type: none"> • Ensure the unit is connected. • Ensure that there is no damage to the cable or connector.

Note: If a disturbance occurs on the video monitor, the user should ensure that the probe cable is not near any other instrument cables.

Cleaning and Maintenance

Cleaning

Console

Should the console need cleaning, wipe it down with a sterile cloth and mild cleaning solution. If needed, wipe the console with a disinfectant.

Warning



To avoid electric shock and potentially fatal injury, unplug the Crossfire™ console from the electrical outlet before cleaning.

Do not sterilize the console or immerse it in any liquid. Doing so will damage the unit.

Do not clean the console with alcohol, solvents, or cleaning solutions that contain ammonia. Doing so will damage the unit.

Footswitch

Consult the footswitch user guide for cleaning and reprocessing instructions.

RF Handpiece

RF handpieces are intended for single use only and should not be cleaned, sterilized, or reused.

Shaver Handpiece

Consult the appropriate user guide for cleaning and reprocessing instructions.

Disposable attachments are intended for single use only and should not be cleaned, sterilized, or reused.

Maintenance

The Crossfire™ console requires no preventative or periodic maintenance. However, Stryker recommends you reboot the system daily for best performance.

Disposal



This product contains electrical waste or electronic equipment. It must not be disposed of as unsorted municipal waste and must be collected separately in accordance with applicable national or institutional related policies relating to obsolete electronic equipment.

Dispose of any system accessories according to normal institutional practice relating to potentially contaminated items.

Technical Specifications

Stryker Endoscopy reserves the right to make improvements to the product(s) described herein. Product(s), therefore, may not agree in detail to the published design or specifications. All specifications are subject to change without notice. Please contact the local Stryker Endoscopy distributor or call your local Stryker Endoscopy sales representative or agent for information on changes and new products.

Dimensions

Size:	16.9" L × 12.5" H × 4.5" W
Weight:	20 lbs

Environmental Specifications

Operating temperature:	5 – 40°C
Operating humidity:	30 – 95% RH
Shipping temperature:	-18 – 60°C
Shipping humidity:	15 – 90% RH

System Input Power Requirements

Voltage:	100-240 VAC @ 50/60Hz, 6 – 10 A
Inlet Fuse:	15 A, 250V

Electrical Specifications

Motor output max speed:	12000 RPM
Motor duty cycle:	Continuous operation
RF output waveform:	200 kHz ± 1%, square wave, Crest factor <1.5 @ 200 ohms

Generator Output

Output power at each set point with specified load resistance (per IEC 60601-2-2, sub clause 6.8.3) is given in the graphs below.

Output Power versus Setting at 200ohms Resistive Load

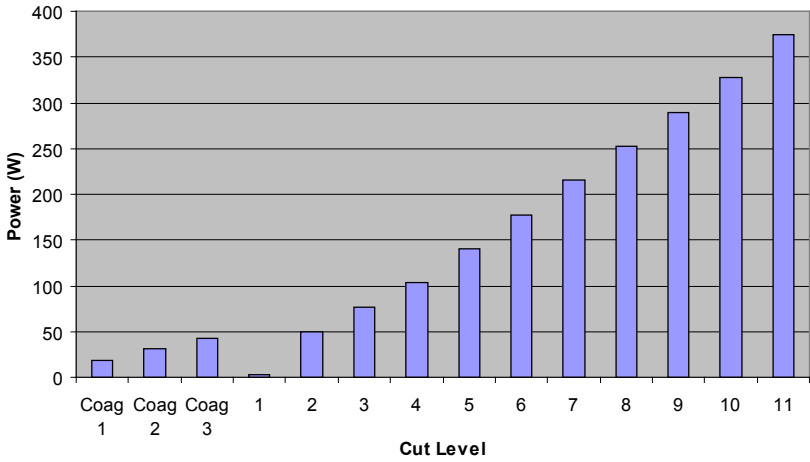

Output Power (CUT) versus Load Resistance

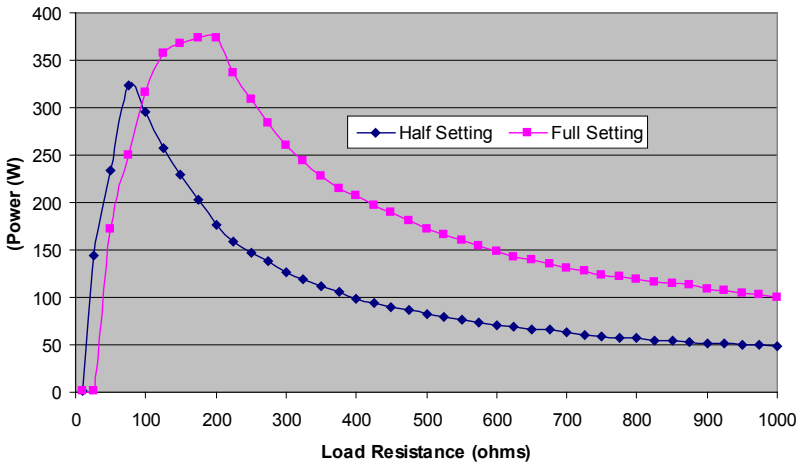

Output Power (COAG) versus Load Resistance

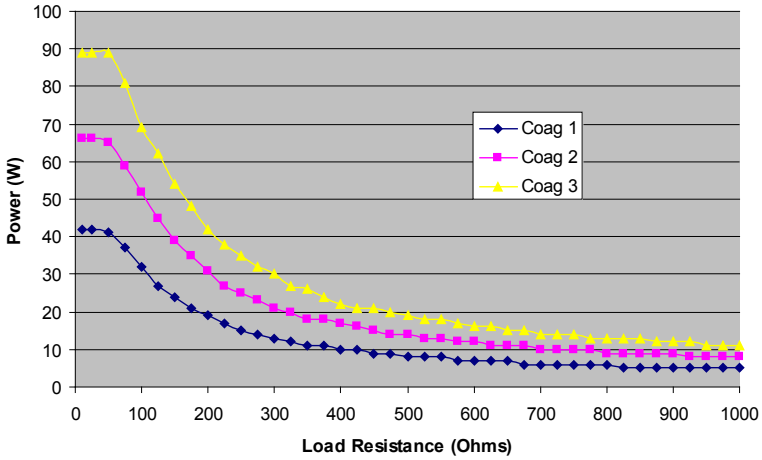

Maximum Open Circuit Voltage versus Set Point

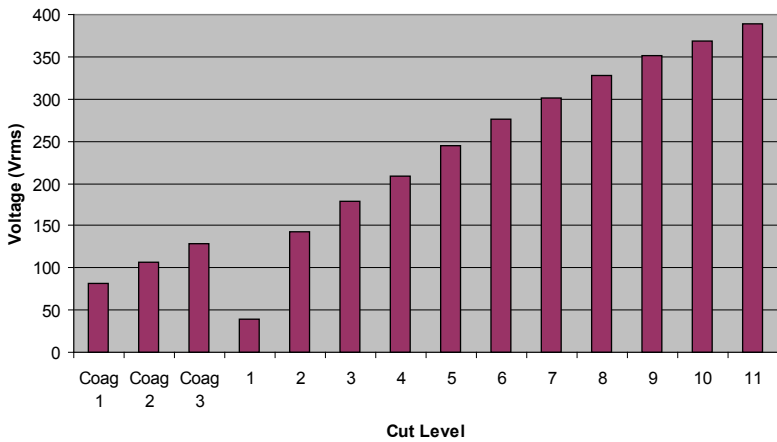

Classifications

Warning This equipment is not suitable for use in the presence of a flammable anesthetic mixture with air, oxygen, or nitrous oxide.



- Class I equipment
- Type BF applied part
- Degree of protection against harmful ingress of water
 - Generator: IEC 60601-2-2: Requirement per clause 44.3
 - Probe: IEC 60601-2-2: Requirement per clause 44.6
 - Footswitch: IEC 60601-2-2: Requirement per clause 44.6, IPX7 Water-tight Equipment

Approvals

Complies with medical safety standards:

- IEC 60601-1: 1998 + A1:1991 + A2:1995
- AS 3200.1.0: 1998
- IEC 60601-1-2: 2001
- IEC 60601-2-2: 2006
- UL 60601-1: 2003
- CSA C22.2 No. 601-1-M90

Federal Communications Commission (FCC)

FCC ID: SSH-XFC

Trade Name: Crossfire™ Console

Type or Model: 0475000000

This device complies with Part 15 of the FCC rules. Operation is subject to the following two conditions:

1. this device may not cause harmful interference, and
2. this device must accept any interference received, including interference that may cause undesired operation.

Note: FCC regulations provide that changes or modifications not expressly approved by Stryker Endoscopy could void your authority to operate this equipment.

Frequency of transmission: 13.56MHz

Type of frequency / characteristics of the modulation: 10% ASK

Subcarrier: 423.75kHz, Manchester coding

Effective radiated power: 50μW

Industry Canada (IC)

IC: 4919C-XFC

Trade Name: Crossfire™ Console

Type or Model: 0475000000

Operation is subject to the following two conditions: (1) this device may not cause interference, and (2) this device must accept any interference, including interference that may cause undesired operation of the device.

The term “IC” before the radio certification number only signifies that Industry Canada technical specifications were met.

R&TTE Declaration of Conformity (DoC)

We, **Name of company:** Stryker Endoscopy
Address: 5900 Optical Court, San Jose, CA 95138
Authorized representative: Jean-Yves Carentz
Contact detail of authorized representative: Stryker France,
ZAC Satolas Green Pusignan, Av. de Satolas Green, 69881
MEYZIEU Cedex, France

Declare under our sole responsibility that the product:

Product name: Crossfire™ Integrated Arthroscopy System
Trade Name: Crossfire™ Console
Type or Model: 0475000000
Relevant Supplementary Information: None

to which this declaration relates is in conformity with the essential requirements and other relevant requirements of the R&TTE Directive (1999/5/EC).

The product is compliant with the following standards and/or other normative documents:

Safety: EN 60601-1-1:1990+A1:1993+A2:1995+A13:1996
EMC: EN 60601-1-2:2007; EN 61000-3-2:2006
Radio Spectrum: EN 300 330-1 V1.5.1

Supplementary information: none

Notified body involved: TÜV Rheinland Product Safety (GmbH)

Technical file held by: Stryker Endoscopy

Place and date of issue (of this DoC): San Jose, CA USA,
August 2009

Signed by or for the manufacturer:

Name: K. Jeffrey Semone
Title: Director, Regulatory Affairs

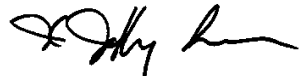

Hereby, Stryker Endoscopy declares that this Short Range Device is in compliance with the essential requirements and other relevant provisions of Directive 1999/5/EC.

stryker[®]



Stryker Endoscopy
5900 Optical Court
San Jose, CA 95138 USA
1-408-754-2000, 1-800-624-4422
www.stryker.com

CE₀₁₉₇



European Representative:
Regulatory Manager, Stryker France
ZAC Satolas Green Pusignan
Av. De Satolas Green
69881 MEYZIEU Cedex, France

1000-401-036 Rev G
2009/10